

D3G146-AH50-01

EC centrifugal fan

forward-curved, dual-intake
with housing (without flange)

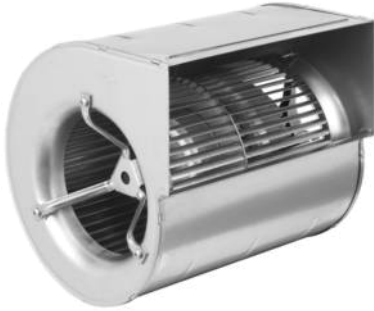

ASIA PACIFIC SHENGRUI LIMITED

Phone +00852 56261528

info@apacfan.com

www.apacfan.com



Nominal data

Type	D3G146-AH50-01	
Motor	M3G074-CF	
Phase		1~
Nominal voltage	VAC	230
Nominal voltage range	VAC	200 .. 277
Frequency	Hz	50
Method of obtaining data		fa
Speed (rpm)	min ⁻¹	1700
Power consumption	W	165
Current draw	A	1.2
Min. ambient temperature	°C	-25
Max. ambient temperature	°C	60

ml = Max. load · me = Max. efficiency · fa = Free air · cs = Customer specification · ce = Customer equipment
Subject to change

Data according to ErP Directive

		Actual	Req. 2015
01 Overall efficiency η_{es}	%	43.4	32.6
02 Measurement category		A	
03 Efficiency category		Static	
04 Efficiency grade N		54.8	44
05 Variable speed drive		Yes	

Data obtained at optimum efficiency level.

The ErP data is determined using a motor-impeller combination in a standardized measurement setup.

09 Power consumption P_{ed}	kW	0.16
09 Air flow q_v	m ³ /h	645
09 Pressure increase p_{fs}	Pa	350
10 Speed (rpm) n	min ⁻¹	2400
11 Specific ratio*		1.00

* Specific ratio = $1 + p_{fs} / 100\,000\text{ Pa}$

LU-105178



D3G146-AH50-01

EC centrifugal fan

forward-curved, dual-intake
with housing (without flange)

Technical description

Weight	3.9 kg
Fan size	146 mm
Rotor surface	Painted black
Electronics housing material	Die-cast aluminum
Impeller material	Sheet steel, galvanized
Housing material	Sheet steel, galvanized
Motor suspension	Motor vibration-damped on both sides
Direction of rotation	Clockwise, viewed toward rotor
Degree of protection	IP44; installation- and position-dependent
Insulation class	"B"
Moisture (F) / Environmental (H) protection class	F3-1
Max. permitted ambient temp. for motor (transport/storage)	+ 80 °C
Min. permitted ambient temp. for motor (transport/storage)	- 40 °C
Installation position	Shaft horizontal; rotor on top or rotor on bottom on request
Condensation drainage holes	None
Mode	S1
Motor bearing	Ball bearing
Technical features	<ul style="list-style-type: none">- Output 10 VDC, max. 1.1 mA- Tach output- Motor current limitation- Soft start- Control input 0-10 VDC / PWM- Thermal overload protection for electronics/motor
EMC immunity to interference	According to EN 61000-6-2 (industrial environment)
EMC circuit feedback	According to EN 61000-3-2/3
EMC interference emission	According to EN 61000-6-3 (household environment)
Touch current according to IEC 60990 (measuring circuit Fig. 4, TN system)	<= 3.5 mA
Motor protection	Thermal overload protector (TOP) internally connected
With cable	Variable
Protection class	I (with customer connection of protective earth)
Conformity with standards	EN 60335-1; CE
Approval	CCC; EAC; UL 2111; CSA C22.2 No. 77



EC centrifugal fan

forward-curved, dual-intake
with housing (without flange)

Product drawing

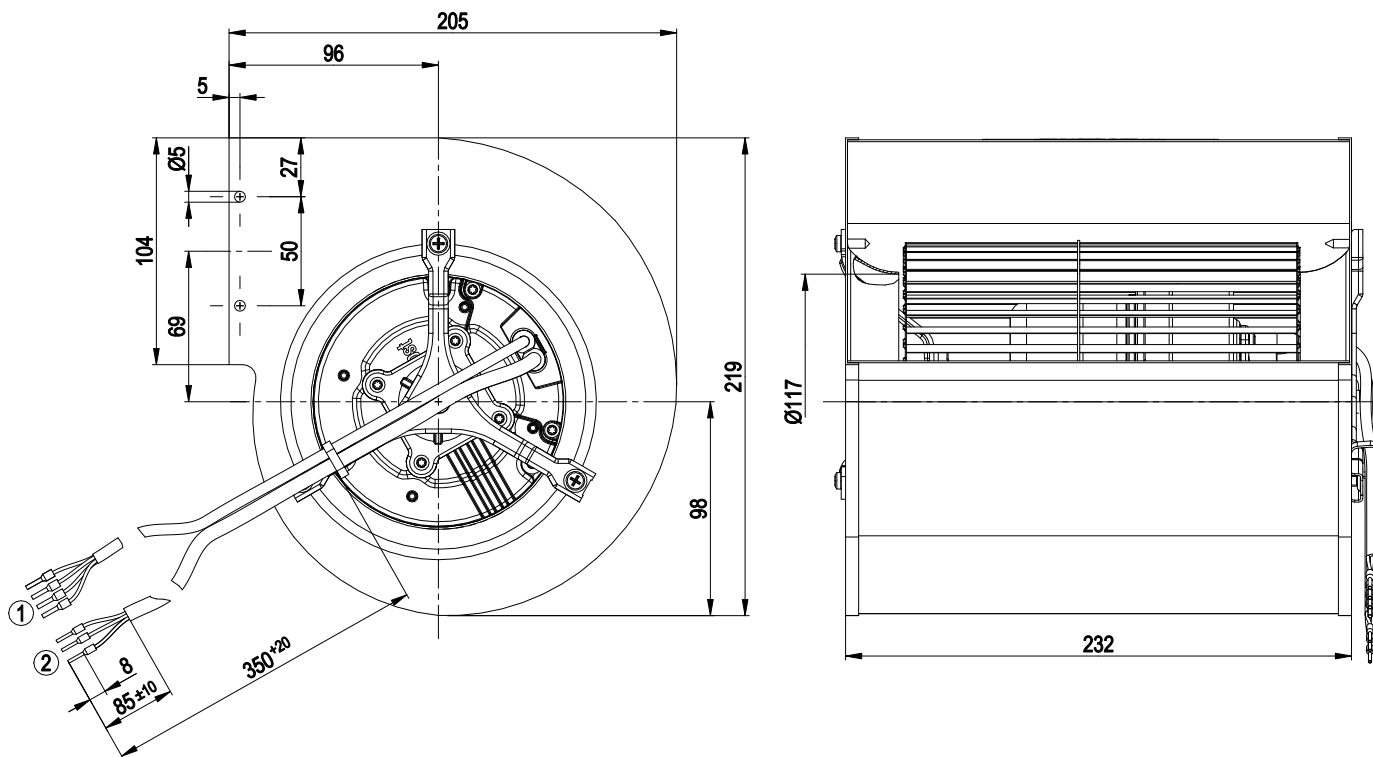

- | | |
|---|--------------------------------------|
| 1 | Cable PVC AWG22, 4x crimped ferrules |
| 2 | Cable PVC AWG18, 3x crimped ferrules |

EC centrifugal fan

forward-curved, dual-intake
with housing (without flange)

Connection diagram

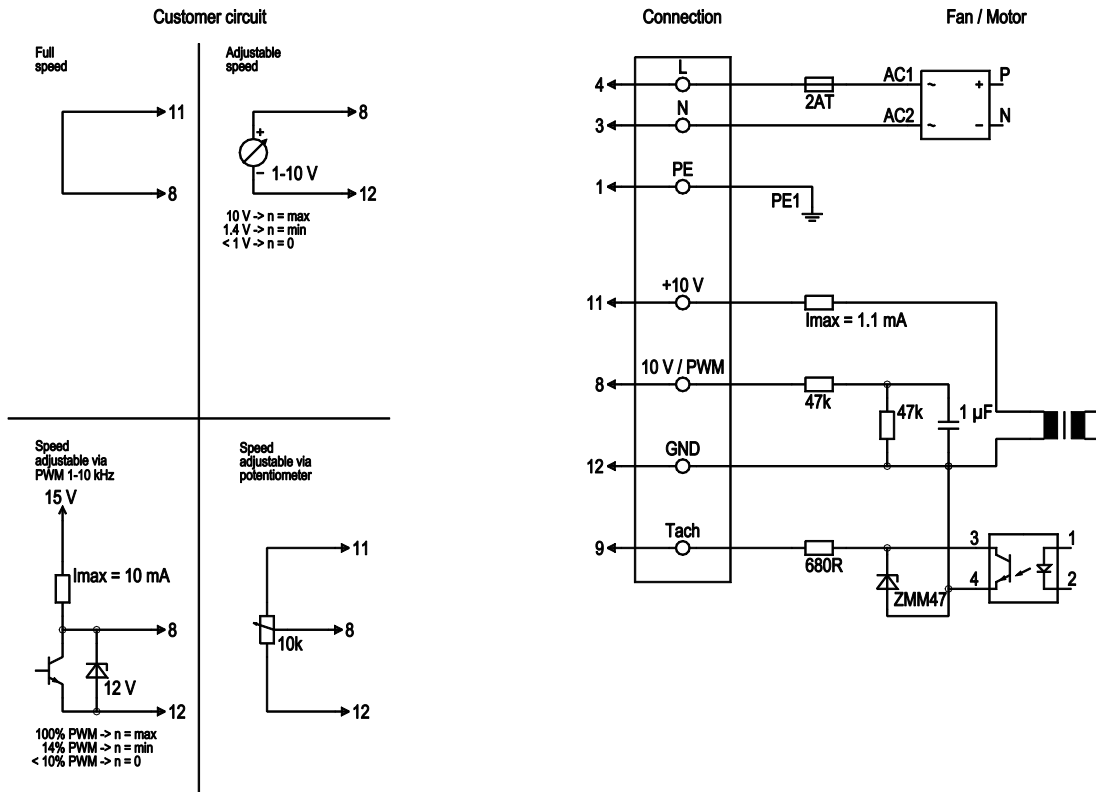

No.	Conn.	Designation	Color	Function/assignment
	4	L	black	Power supply 230 VAC, 50-60 Hz, see nameplate for voltage range
	3	N	blue	Neutral conductor
	1	PE	green/yellow	Protective earth
	8	0-10 V PWM	yellow	Control input 0-10 V or PWM, electrically isolated
	9	Tach	white	Tach output: open collector, 1 pulse per revolution, electrically isolated
	11	10V / max 1.1 mA	red	Voltage output 10 V/max. 1.1 mA, electrically isolated
	12	GND	blue	GND connection for control interface



EC centrifugal fan

forward-curved, dual-intake
with housing (without flange)

Curves: Air performance 50 Hz

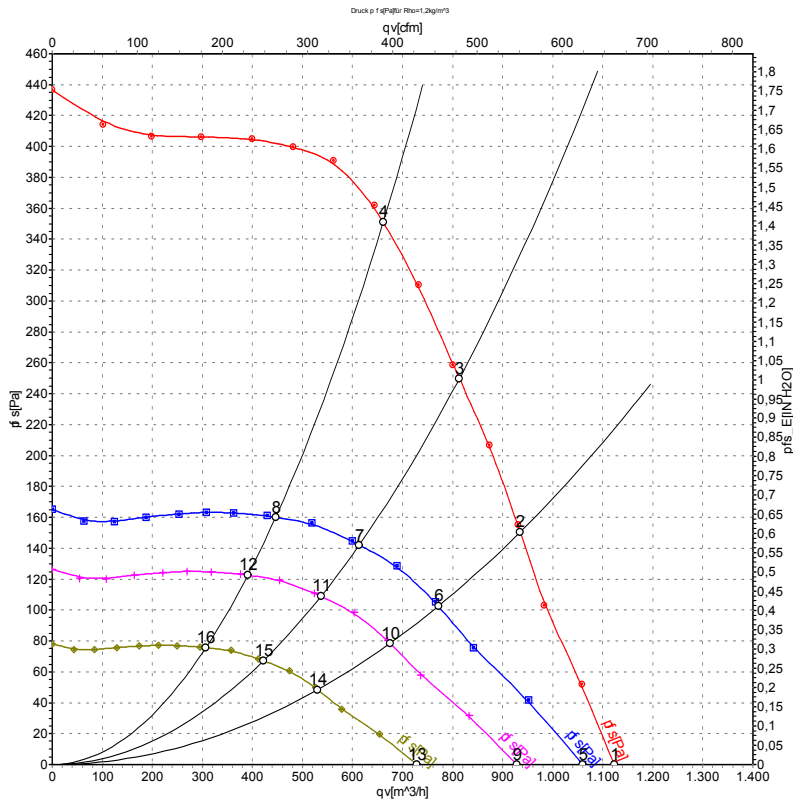

Measurement: LU-105178-1

Air performance measured according to ISO 5801 installation category A. For detailed information on the measurement setup, contact ebm-papst. Intake sound level: Sound power level according to ISO 13347 / sound pressure level measured at 1 m distance from fan axis. The values given are valid under the specified measuring conditions and may vary due to conditions of installation. For deviations from the standard configuration, the parameters have to be checked on the installed unit.

Measured values

	U	f	n	P _{ed}	I	q _v	P _{fs}	q _v	P _{fs}
	V	Hz	min ⁻¹	W	A	m ³ /h	Pa	cfm	inH2O
1	230	50	1700	165	1.20	1125	0	660	0.00
2	230	50	1935	165	1.20	935	150	550	0.60
3	230	50	2120	165	1.20	815	250	480	1.00
4	230	50	2370	165	1.20	660	350	390	1.41
5	230	50	1600	139	1.00	1060	0	625	0.00
6	230	50	1600	93	0.68	770	103	455	0.41
7	230	50	1600	71	0.53	615	142	360	0.57
8	230	50	1600	51	0.38	445	160	265	0.64
9	230	50	1400	93	0.67	930	0	545	0.00
10	230	50	1400	62	0.45	675	79	395	0.32
11	230	50	1400	48	0.35	535	109	315	0.44
12	230	50	1400	34	0.25	390	123	230	0.49
13	230	50	1100	45	0.33	730	0	430	0.00
14	230	50	1100	30	0.22	530	49	310	0.20
15	230	50	1100	23	0.17	420	67	250	0.27
16	230	50	1100	17	0.12	305	76	180	0.31

U = Power supply · f = Frequency · n = Speed (rpm) · P_{ed} = Power consumption · I = Current draw · q_v = Air flow · P_{fs} = Pressure increase

