

AC axial fan

sickle-shaped blades (S series)

with guard grille

ASIA PACIFIC SHENGRUI LIMITED

Phone +00852 56261528

info@apacfan.com

www.apacfan.com

Nominal data

Type	VNQ0300X3NGZ		
Motor	M2D074-DF		
Phase		1~	1~
Nominal voltage	VAC	400	400
Wiring		Y	Y
Frequency	Hz	50	60
Method of obtaining data		fa	fa
Valid for approval/standard		-	-
Speed (rpm)	min ⁻¹	2600	2850
Power consumption	W	195	275
Current draw	A	0.33	0.43
Max. back pressure	Pa	200	125
Max. back pressure	in. wg	0.8	0.5
Min. ambient temperature	°C	-25	-25
Max. ambient temperature	°C	75	40
Starting current	A	1.16	1.1

ml = Max. load · me = Max. efficiency · fa = Free air · cs = Customer specification · ce = Customer equipment
Subject to change

Data according to Commission Regulation (EU) 327/2011

		Actual	Req. 2015			
01 Overall efficiency η_{es}	%	29.9	29.9	09 Power consumption P_e	kW	0.25
02 Measurement category		A		09 Air flow q_v	m ³ /h	2210
03 Efficiency category		Static		09 Pressure increase p_{fs}	Pa	125
04 Efficiency grade N		40	40	10 Speed (rpm) n	min ⁻¹	2455
05 Variable speed drive		No		11 Specific ratio*		1.00

Data obtained at optimum efficiency level.
The ErP data is determined using a motor-impeller combination in a standardized measurement setup.

* Specific ratio = $1 + p_{fs} / 100\,000\text{ Pa}$

LU-62732



AC axial fan

sickle-shaped blades (S series)

with guard grille

Technical description

Weight	3.6 kg
Size	300 mm
Motor size	74
Rotor surface	Painted black
Blade material	Sheet steel, painted black
Guard grille material	Steel, coated with black plastic (RAL 9005)
Number of blades	5
Airflow direction	A
Direction of rotation	Clockwise, viewed toward rotor
Degree of protection	IP44; installation- and position-dependent
Insulation class	"F"
Moisture (F) / Environmental (H) protection class	H1
Max. permitted ambient temp. for motor (transport/storage)	+80 °C
Min. permitted ambient temp. for motor (transport/storage)	-40 °C
Installation position	Any
Condensation drainage holes	None
Mode	S1
Motor bearing	Ball bearing
Touch current according to IEC 60990 (measuring circuit Fig. 4, TN system)	< 0.75 mA
With cable	Variable
Protection class	I (with customer connection of protective earth)

AC axial fan

sickle-shaped blades (S series)
with guard grille

Product drawing

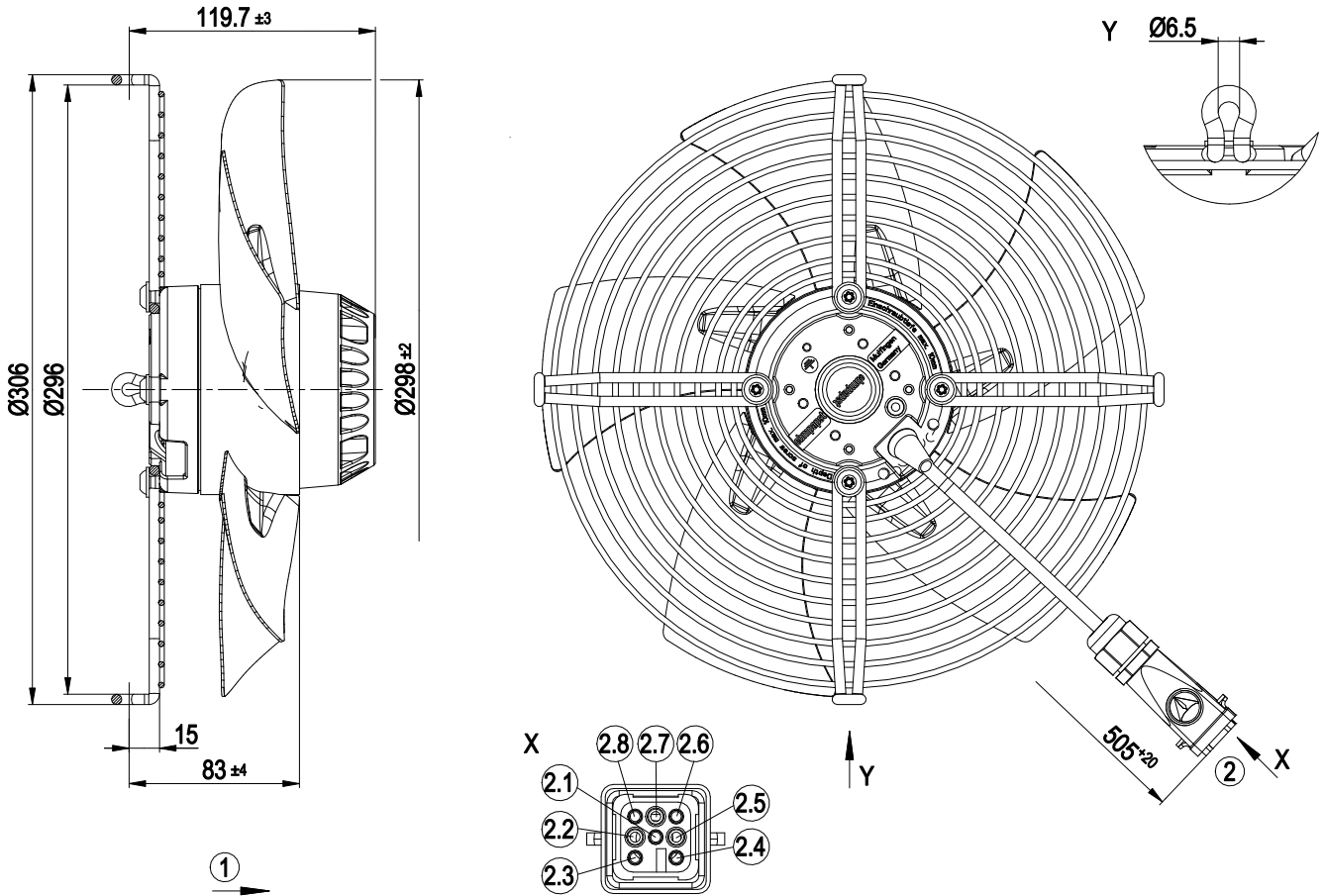

1	Direction of air flow "A"
2	Cable silicone 4G 0.5 mm ²
	Connector housing 8-pole Amphenol C14610A0070002F, sleeve housing Amphenol C14610G0036004F, 4x plug pin Amphenol TN01-016-0002-1
2.1	not used
2.2	not used
2.3	U1 (black)
2.4	V1 (blue)
2.5	not used
2.6	W1 (brown)
2.7	not used
2.8	PE (green/yellow)



AC axial fan

sickle-shaped blades (S series)
with guard grille

Connection diagram

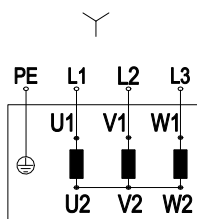

Note: Change of rotation direction by reversing two phases

Y	Star connection	L1	black	L2	blue
L3	brown	U1	black	V1	blue
W1	brown	U2	green	V2	white
W2	yellow	PE	green/yellow		

AC axial fan

sickle-shaped blades (S series)
with guard grille

Curves: Air performance 50 Hz

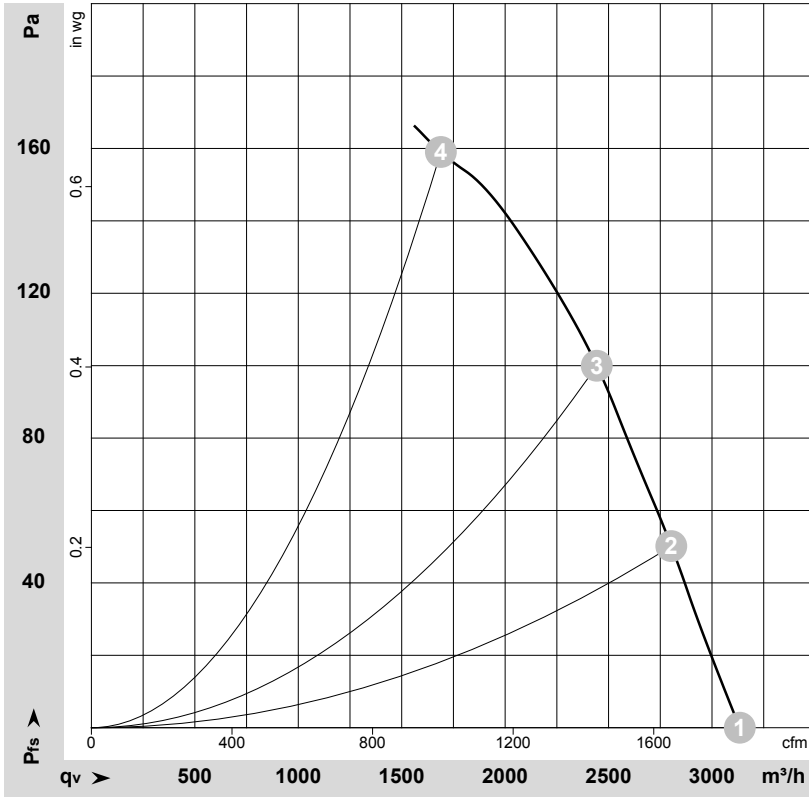

$\rho = 1.15 \text{ kg/m}^3 \pm 2 \%$

Measurement: LU-62732-1

Air performance measured according to ISO 5801 installation category A. For detailed information on the measurement setup, contact ebmpapst. Intake sound level: Sound power level according to ISO 13347 / sound pressure level measured at 1 m distance from fan axis. The values given are valid under the specified measuring conditions and may vary due to conditions of installation. For deviations from the standard configuration, the parameters have to be checked on the installed unit.

Measured values

	Wired	U	f	n	P _e	I	q _v	P _{fs}	q _v	P _{fs}
		V	Hz	min ⁻¹	W	A	m ³ /h	Pa	cfm	in. wg
1	Y	400	50	2580	210	0.36	3135	0	1845	0.00
2	Y	400	50	2540	228	0.36	2805	50	1650	0.20
3	Y	400	50	2490	244	0.39	2445	100	1440	0.40
4	Y	400	50	2385	281	0.44	1690	160	995	0.64

Wired = Wiring · U = Voltage · f = Frequency · n = Speed (rpm) · P_e = Power consumption · I = Current draw · q_v = Air flow · P_{fs} = Pressure increase



AC axial fan

sickle-shaped blades (S series)
with guard grille

Curves: Air performance 60 Hz

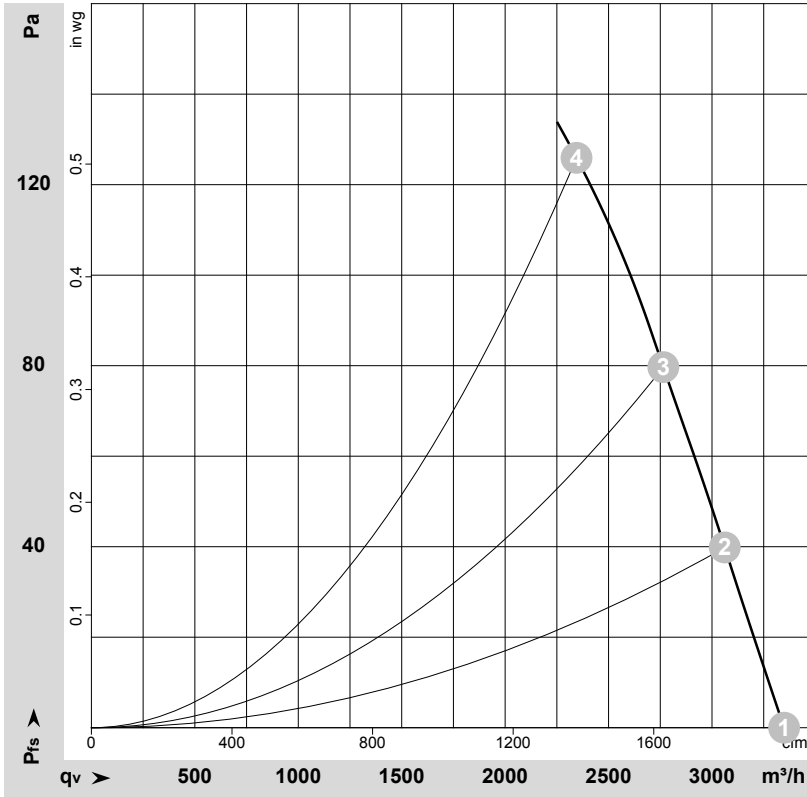

$\rho = 1.15 \text{ kg/m}^3 \pm 2 \%$

Measurement: LU-62733-1

Air performance measured according to ISO 5801 installation category A. For detailed information on the measurement setup, contact ebm-papst. Intake sound level: Sound power level according to ISO 13347 / sound pressure level measured at 1 m distance from fan axis. The values given are valid under the specified measuring conditions and may vary due to conditions of installation. For deviations from the standard configuration, the parameters have to be checked on the installed unit.

Measured values

	U	f	n	P _e	I	q _v	p _{fs}	q _v	p _{fs}
	V	Hz	min ⁻¹	W	A	m ³ /h	Pa	cfm	in. wg
1	400	60	2750	300	0.48	3350	0	1970	0.00
2	400	60	2685	316	0.48	3060	40	1800	0.16
3	400	60	2625	331	0.50	2765	80	1625	0.32
4	400	60	2540	349	0.53	2345	125	1380	0.50

U = Voltage · f = Frequency · n = Speed (rpm) · P_e = Power consumption · I = Current draw · q_v = Air flow · p_{fs} = Pressure increase

