

ASIA PACIFIC SHENGRUI LIMITED

Phone +00852 56261528

info@apacfan.com

www.apacfan.com

Nominal data

Type	R2E190-RB06-13		
Motor	M2E068-CF		
Phase		1~	1~
Nominal voltage	VAC	230	230
Frequency	Hz	60	60
Method of obtaining data		fa	fa
Valid for approval/standard		CE	UL 2111
Speed (rpm)	min ⁻¹	3150	3150
Power consumption	W	112	117
Current draw	A	0.50	0.50
Capacitor	μF	3	3
Capacitor voltage	VDB	400	400
Capacitor standard		S0 (CE)	UL
Min. back pressure	Pa	0	0
Min. back pressure	in. wg	0	0
Min. ambient temperature	°C	-25	-25
Max. ambient temperature	°C	60	60
Starting current	A	0.87	

ml = Max. load · me = Max. efficiency · fa = Free air · cs = Customer specification · ce = Customer equipment
Subject to change



Technical description

Weight	1.67 kg
Size	190 mm
Motor size	68
Rotor surface	Painted black
Impeller material	PA plastic
Number of blades	7
Direction of rotation	Clockwise, viewed toward rotor
Degree of protection	IP44; installation- and position-dependent as per EN 60034-5
Insulation class	"B"
Moisture (F) / Environmental (H) protection class	H1
Max. permitted ambient temp. for motor (transport/storage)	+ 80 °C
Min. permitted ambient temp. for motor (transport/storage)	- 40 °C
Installation position	Shaft horizontal or rotor on bottom; rotor on top on request
Condensation drainage holes	On rotor side
Mode	S1
Motor bearing	Ball bearing
Touch current according to IEC 60990 (measuring circuit Fig. 4, TN system)	< 0.75 mA
Electrical hookup	Connector with cable
Motor protection	Thermal overload protector (TOP) internally connected
With cable	Variable
Protection class	I (if protective earth is connected by customer to the housing's connection point)
Conformity with standards	EN 60034-1; EN 60204-1; CE
Approval	UL 1004-3; CSA C22.2 No. 77; CCC

Product drawing

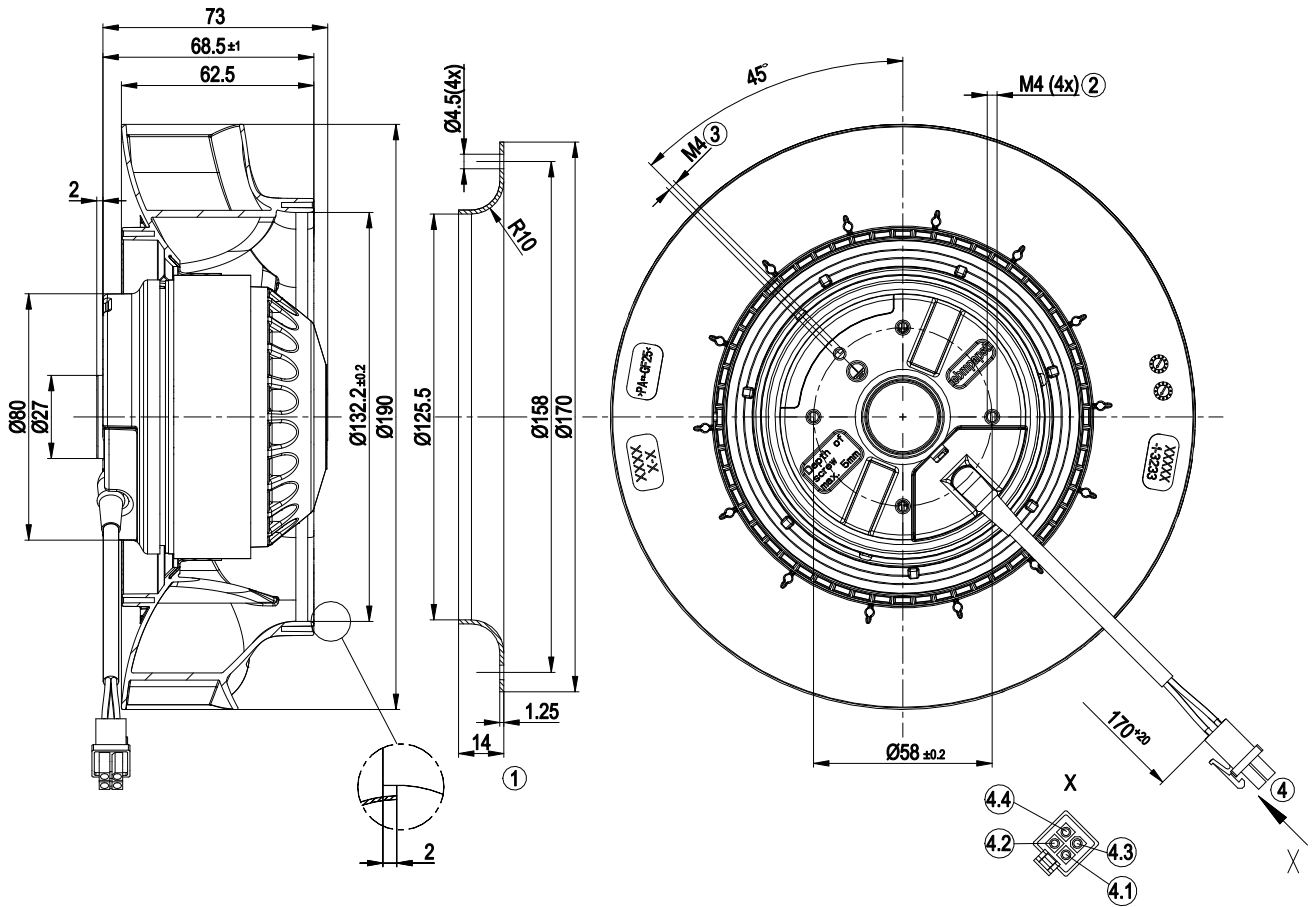

1	Accessory part: inlet ring 09576-2-4013, not included in scope of delivery
2	Max. clearance for screw 5 mm
3	Max. clearance for screw 5 mm
4	Cable PVC AWG20, 4-pole connector housing tyco 172167-1, 3x socket tyco 170362-1
4.1	not used
4.2	black
4.3	brown
4.4	blue

Connection diagram

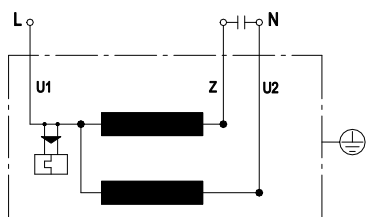

U1	blue	Z	brown	U2	black
----	------	---	-------	----	-------

Curves: Air performance 60 Hz

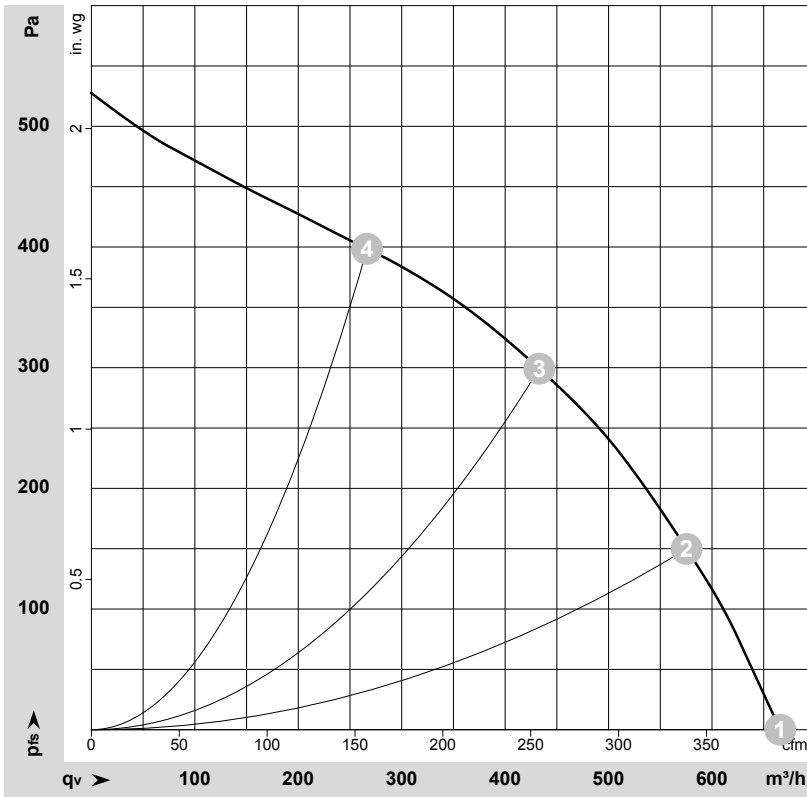

$\rho = 1.15 \text{ kg/m}^3 \pm 2 \%$

Measurement: LU-127892-1

Air performance measured according to ISO 5801 installation category A. For detailed information on the measurement setup, contact ebmpapst. Intake sound level: Sound power level according to ISO 13347 / sound pressure level measured at 1 m distance from fan axis. The values given are valid under the specified measuring conditions and may vary due to conditions of installation. For deviations from the standard configuration, the parameters have to be checked on the installed unit.

Measured values

	Wired	U	f	n	P _e	I	LpA _{in}	LwA _{in}	q _v	P _{fs}	q _v	P _{fs}
		V	Hz	min ⁻¹	W	A	dB(A)	dB(A)	m ³ /h	Pa	cfm	in. wg
1	1~	230	60	3255	101	0.45	67	74	665	0	390	0.00
2	1~	230	60	3225	105	0.47	63	70	575	150	340	0.60
3	1~	230	60	3150	112	0.50	60	68	435	300	255	1.20
4	1~	230	60	3210	107	0.48	63	71	265	398	155	1.60

Wired = Wiring · U = Voltage · f = Frequency · n = Speed (rpm) · P_e = Power consumption · I = Current draw · LpA_{in} = Sound pressure level intake side · LwA_{in} = Sound power level intake side
 q_v = Air flow · P_{fs} = Pressure increase