



ASIA PACIFIC SHENGRUI LIMITED

Phone +00852 56261528

info@apacfan.com

www.apacfan.com



Nominal data

Type	A4D350-AN08-13				
Motor	M4D074-DF				
Phase		3~	3~	3~	3~
Nominal voltage	VAC	230	230	400	400
Connection		Δ	Δ	Y	Y
Frequency	Hz	50	60	50	60
Type of data definition		ml	ml	ml	ml
Valid for approval / standard		CE	CE	CE	CE
Speed	min ⁻¹	1370	1520	1370	1520
Power input	W	170	230	170	230
Current draw	A	0.64	0.70	0.37	0.40
Max. back pressure	Pa	90	90	90	90
Min. ambient temperature	°C	-25	-25	-25	-25
Max. ambient temperature	°C	65	55	65	55
Starting current	A	1.9	1.9	1.1	1.1

ml = Max. load · me = Max. efficiency · fa = Running at free air · cs = Customer specs · cu = Customer unit
Subject to alterations

Data according to ErP directive

Installation category	A
Efficiency category	Static
Variable speed drive	No
Specific ratio*	1.00

* Specific ratio = $1 + p_{fs} / 100\,000\text{ Pa}$

	Actual	Request 2013	Request 2015
Overall efficiency η_{es}	28.7	24.6	28.6
Efficiency grade N	40.1	36	40
Power input P_e	kW	0.16	
Air flow q_v	m ³ /h	2105	
Pressure increase p_{fs}	Pa	82	
Speed n	min ⁻¹	1375	

Data definition with optimum efficiency.
The ErP data is determined using a motor-impeller combination in a standardised measurement configuration.



Technical features

Mass	3.2 kg
Size	350 mm
Surface of rotor	Coated in black
Material of blades	PP plastic
Number of blades	5
Direction of air flow	"V"
Direction of rotation	Counter-clockwise, seen on rotor
Type of protection	IP 44; Depending on installation and position as per EN 60034-5 The IP protection is guaranteed only if the provided cable guard and terminal box are installed.
Insulation class	"F"
Humidity class	F1-2
Max. permissible ambient motor temp. (transp./ storage)	+ 80 °C
Min. permissible ambient motor temp. (transp./storage)	- 40 °C
Mounting position	Shaft horizontal or rotor on bottom; rotor on top on request
Condensate discharge holes	Rotor-side
Operation mode	S1
Motor bearing	Ball bearing
Touch current acc. IEC 60990 (measuring network Fig. 4, TN system)	< 0.75 mA
Electrical leads	Prepared for terminal box installation/assembly
Cable exit	Variable
Protection class	I (if protective earth is connected by customer)
Product conforming to standard	EN 60335-1

Product drawing

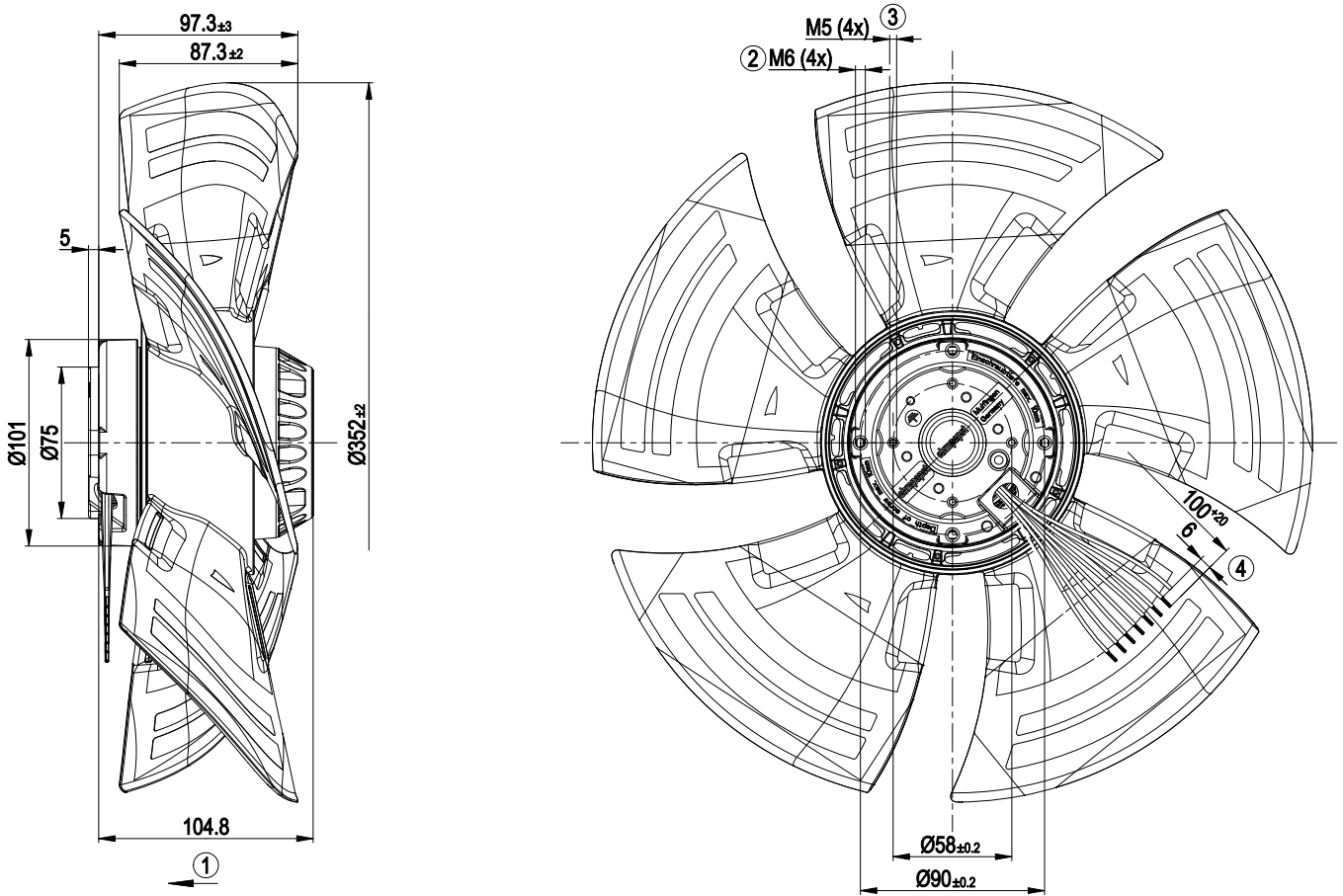

1	Direction of air flow "V"
2	Depth of screw max. 10 mm
3	Depth of screw max. 8 mm
4	Connection line Dipotherm 7G 0.5 mm ² , 7x lead tips crimped

Connection screen

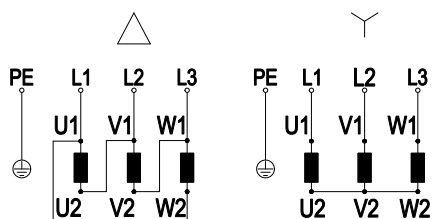

Note: Direction of rotation changes when two phases are reversed

Δ	Delta connection	Y	Star connection	L1	black
L2	blue	L3	brown	U1	black
V1	blue	W1	brown	U2	green
V2	white	W2	yellow	PE	green/yellow

Charts: Air flow 50 Hz

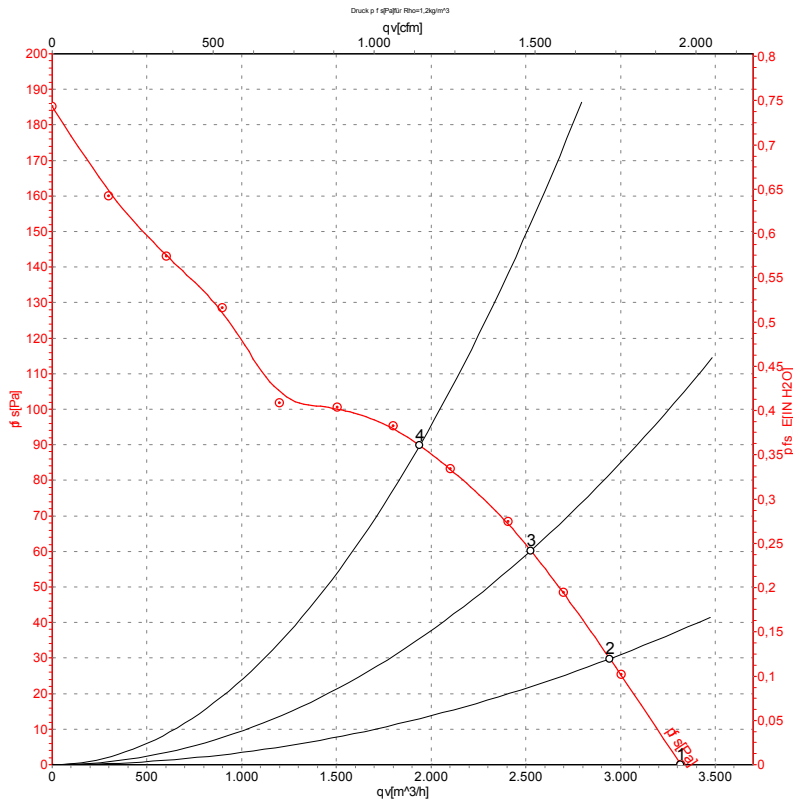

Measurement: LU-131044

Air performance measured as per ISO 5801 Installation category A. For detailed information on the measuring set-up, please contact ebm-papst. Suction-side noise levels: LwA measured as per ISO 13347 / LpA measured with 1m distance to fan axis. The values given are valid under the measuring conditions mentioned above and may vary according to the actual installation situation. With any deviation from the standard set-up, the specific values have to be checked and reviewed with the unit installed.

Measured values

	Conn.	U	f	n	P _e	I	LpA _{in}	LwA _{in}	qv	p _{fs}
		V	Hz	min ⁻¹	W	A	dB(A)	dB(A)	m ³ /h	Pa
1	Y	400	50	1400	140	0.36	61	69	3320	0
2	Y	400	50	1395	147	0.36	59	66	2945	30
3	Y	400	50	1380	157	0.36	56	64	2525	60
4	Y	400	50	1370	170	0.37	55	64	1940	90

Conn. = Connection · U = Supply voltage · f = Frequency · n = Speed · P_e = Power input · I = Current draw · LpA_{in} = Sound pressure level inlet side · LwA_{in} = Sound power level inlet side
 qv = Air flow · p_{fs} = Pressure increase



Charts: Air flow 60 Hz

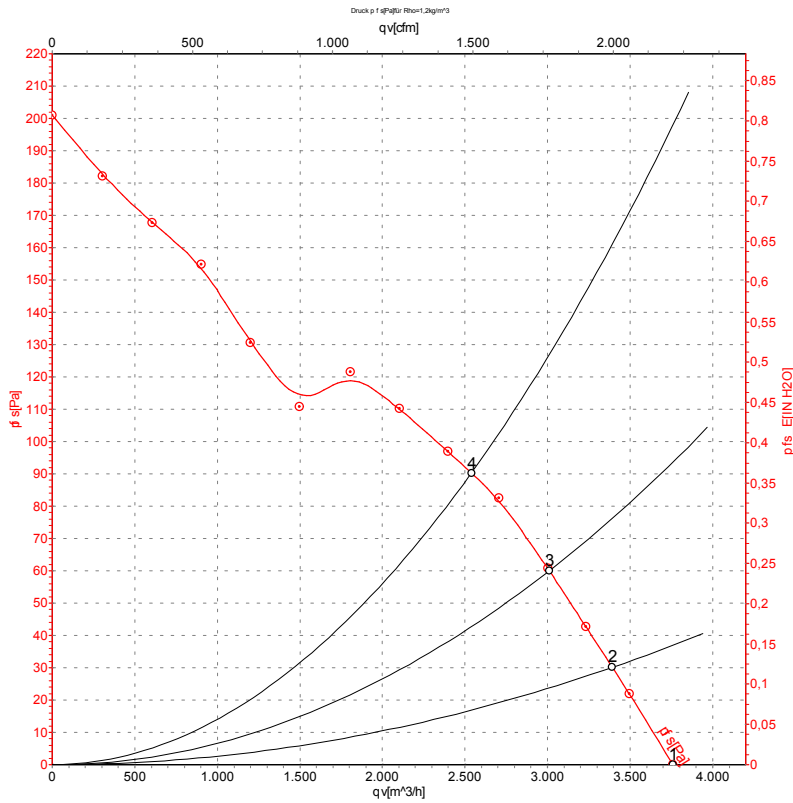

Measurement: LU-131047

Air performance measured as per ISO 5801 Installation category A. For detailed information on the measuring set-up, please contact ebm-papst. Suction-side noise levels: L_{wA} measured as per ISO 13347 / L_{pA} measured with 1m distance to fan axis. The values given are valid under the measuring conditions mentioned above and may vary according to the actual installation situation. With any deviation from the standard set-up, the specific values have to be checked and reviewed with the unit installed.

Measured values

	Conn.	U	f	n	P _e	I	L _{pA_{in}}	L _{wA_{in}}	qv	p _f
		V	Hz	min ⁻¹	W	A	dB(A)	dB(A)	m³/h	Pa
1	Y	400	60	1600	185	0.36	64	72	3760	0
2	Y	400	60	1575	200	0.36	62	69	3390	30
3	Y	400	60	1550	214	0.37	60	67	3010	60
4	Y	400	60	1520	230	0.40	58	66	2540	90

Conn. = Connection · U = Supply voltage · f = Frequency · n = Speed · P_e = Power input · I = Current draw · L_{pA_{in}} = Sound pressure level inlet side · L_{wA_{in}} = Sound power level inlet side
 qv = Air flow · p_f = Pressure increase

