

AC axial fan

sickled blades (S series)
with guard grille for short nozzle

ASIA PACIFIC SHENGRUI LIMITED

Phone +00852 56261528

info@apacfan.com

www.apacfan.com



Nominal data

Type	S4E450-AU03-02		
Motor	M4E094-EA		
Phase		1~	1~
Nominal voltage	VAC	230	230
Frequency	Hz	50	60
Type of data definition		ml	ml
Valid for approval / standard		CE	CE
Speed	min ⁻¹	1300	1490
Power input	W	350	425
Current draw	A	1.55	1.87
Motor capacitor	μF	8	8
Capacitor voltage	VDB	450	450
Max. back pressure	Pa	120	50
Min. ambient temperature	°C	-40	-40
Max. ambient temperature	°C	55	45
Starting current	A	6.0	5.5

ml = Max. load · me = Max. efficiency · fa = Running at free air · cs = Customer specs · cu = Customer unit
Subject to alterations

Data according to ErP directive

Installation category	A
Efficiency category	Static
Variable speed drive	No
Specific ratio*	1.00

* Specific ratio = $1 + p_g / 100\,000\text{ Pa}$

		Actual	Request 2013	Request 2015
Overall efficiency η_{es}	%	32.9	26.6	30.6
Efficiency grade N		42.3	36	40
Power input P_e	kW	0.33		
Air flow q_v	m ³ /h	3920		
Pressure increase p_{fs}	Pa	100		
Speed n	min ⁻¹	1325		

Data definition with optimum efficiency.

LU-71958

The ErP data is determined using a motor-impeller combination in a standardised measurement configuration.



AC axial fan

sickled blades (S series)
with guard grille for short nozzle

Technical features

Mass	7.3 kg
Size	450 mm
Surface of rotor	Coated in black
Material of terminal box	ABS plastic
Material of blades	Press-fitted, coated sheet steel blank, sprayed with PP plastic
Material of guard grille	Steel, coated in black plastic (RAL9005)
Number of blades	5
Direction of air flow	"A"
Direction of rotation	Clockwise, seen on rotor
Type of protection	IP 54
Insulation class	"F"
Humidity class	F4-1
Max. permissible ambient motor temp. (transp./ storage)	+80 °C
Min. permissible ambient motor temp. (transp./storage)	-40 °C
Mounting position	Shaft horizontal or rotor on bottom; rotor on top on request
Condensate discharge holes	Rotor-side
Operation mode	S1
Motor bearing	Ball bearing
Touch current acc. IEC 60990 (measuring network Fig. 4, TN system)	<= 3.5 mA
Electrical leads	Via terminal box, integrated capacitor connected via terminal box
Motor protection	Thermal overload protector (TOP) wired internally
Protection class	I (if protective earth is connected by customer)
Product conforming to standard	EN 60034-1 (2004); CE
Approval	CCC; EAC

AC axial fan

sickled blades (S series)
with guard grille for short nozzle

Product drawing

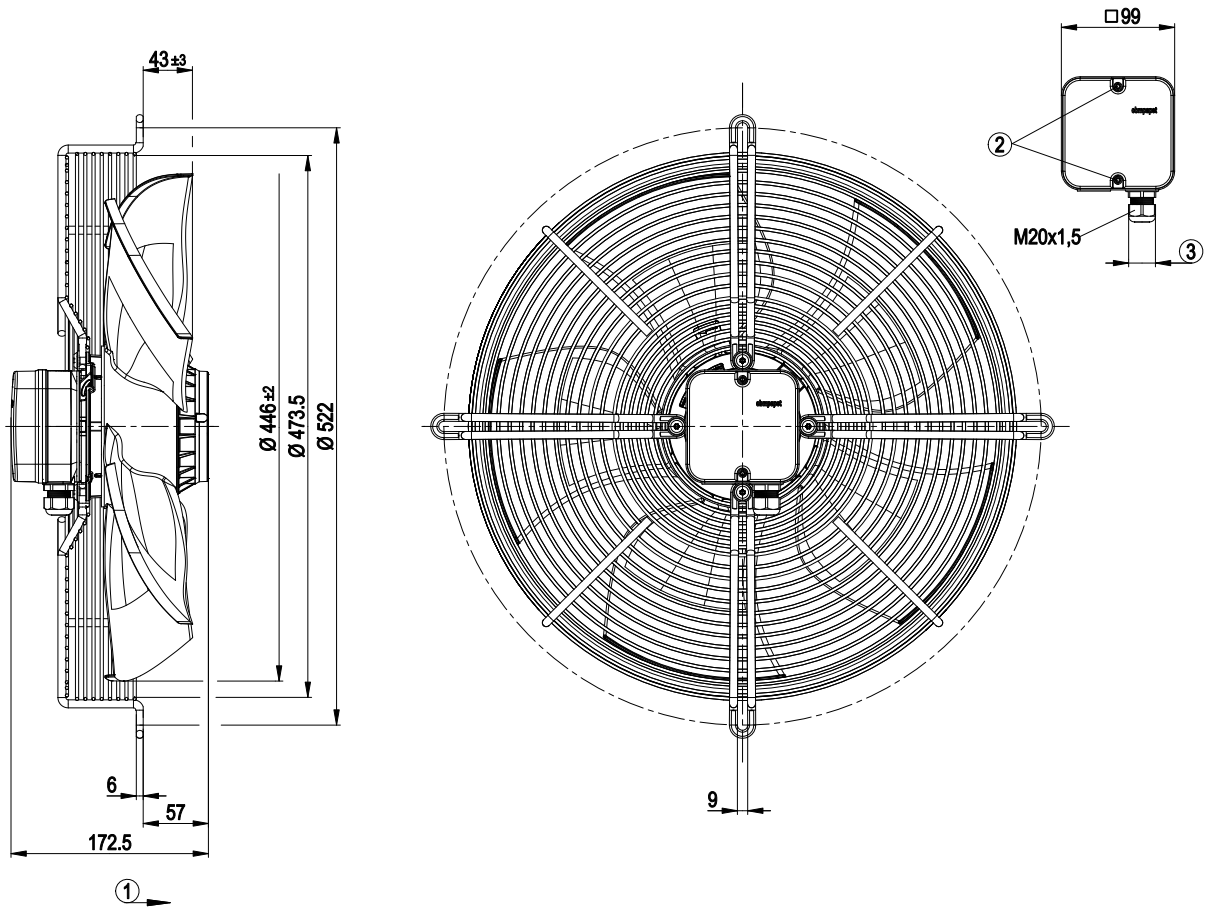

- | | |
|---|---|
| 1 | Direction of air flow "A" |
| 2 | Tightening torque 0.8±0.15 Nm |
| 3 | Cable diameter: min. 6 mm, max. 12 mm, tightening torque: 2 ± 0.15 Nm |

Connection screen

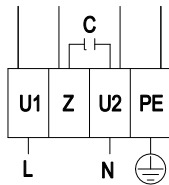

L	= U1 = blue	Z	brown	N	= U2 = black
PE	green/yellow				



AC axial fan

sickled blades (S series)
with guard grille for short nozzle

Charts: Air flow 50 Hz

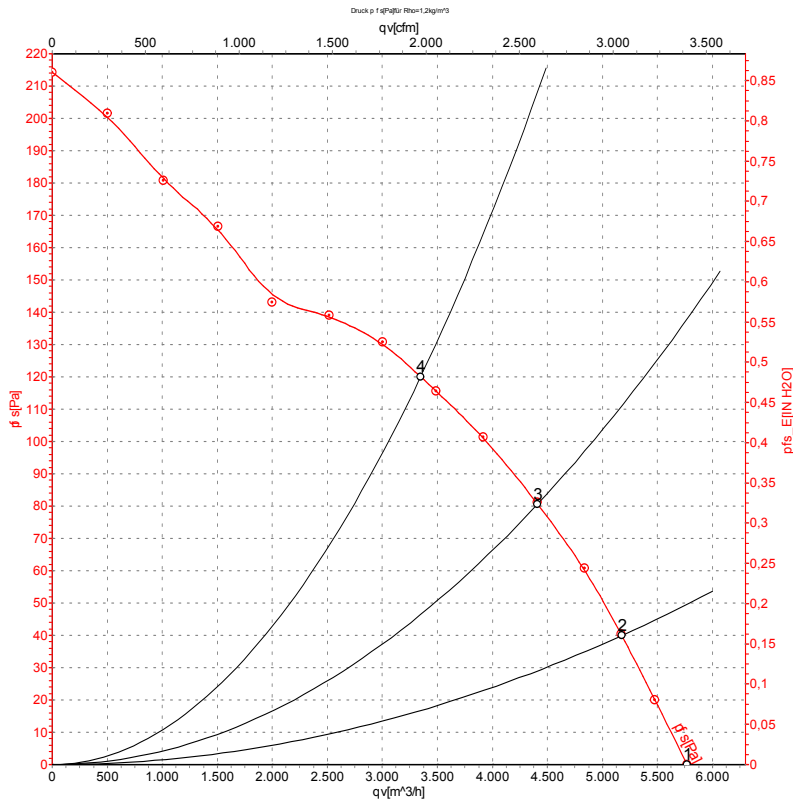

Air performance measured as per ISO 5801 Installation category A. For detailed information on the measuring set-up, please contact ebm-papst. Suction-side noise levels: LwA measured as per ISO 13347 / LpA measured with 1m distance to fan axis. The values given are valid under the measuring conditions mentioned above and may vary according to the actual installation situation. With any deviation from the standard set-up, the specific values have to be checked and reviewed with the unit installed.

Measured values

	U	f	n	P _e	I	LwA _{in}	qv	p _{fs}
	V	Hz	min ⁻¹	W	A	dB(A)	m ³ /h	Pa
1	230	50	1380	272	1.20	74	5770	0
2	230	50	1355	299	1.31	74	5175	40
3	230	50	1340	321	1.40	73	4410	80
4	230	50	1300	350	1.55	73	3350	120

U = Supply voltage · f = Frequency · n = Speed · P_e = Power input · I = Current draw · LwA_{in} = Sound power level inlet side · qv = Air flow · p_{fs} = Pressure increase



AC axial fan

sickled blades (S series)
with guard grille for short nozzle

Charts: Air flow 60 Hz

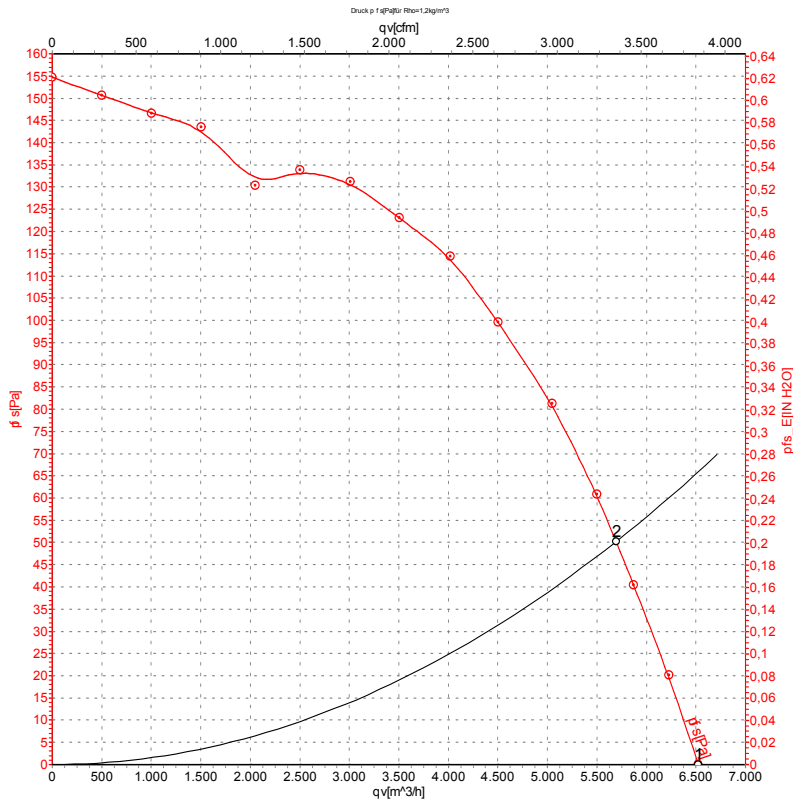

Air performance measured as per ISO 5801 Installation category A. For detailed information on the measuring set-up, please contact ebm-papst. Suction-side noise levels: LwA measured as per ISO 13347 / LpA measured with 1m distance to fan axis. The values given are valid under the measuring conditions mentioned above and may vary according to the actual installation situation. With any deviation from the standard set-up, the specific values have to be checked and reviewed with the unit installed.

Measured values

	U	f	n	P _e	I	LwA _{in}	qv	p _{fs}
	V	Hz	min ⁻¹	W	A	dB(A)	m ³ /h	Pa
1	230	60	1545	396	1.74	76	6525	0
2	230	60	1490	425	1.87	77	5695	50

U = Supply voltage · f = Frequency · n = Speed · P_e = Power input · I = Current draw · LwA_{in} = Sound power level inlet side · qv = Air flow · p_{fs} = Pressure increase

