

## ASIA PACIFIC SHENGRUI LIMITED

Phone +00852 56261528

info@apacfan.com

www.apacfan.com

## Nominal data

Type	R2E225-RA92-10			
Motor	M2E068-DF			
Phase		1~	1~	1~
Nominal voltage	VAC	230	230	230
Frequency	Hz	50	60	60
Method of obtaining data		ml	ml	ml
Valid for approval/standard		CE	CE	UL 2111
Speed (rpm)	min <sup>-1</sup>	2500	2600	2600
Power consumption	W	155	210	225
Current draw	A	0.68	0.92	0.95
Capacitor	μF	3.5	3.5	3.5
Capacitor voltage	VDB	450	450	450
Capacitor standard				UL
Min. back pressure	Pa	0	0	0
Min. back pressure	in. wg	0	0	0
Min. ambient temperature	°C	-25	-25	-25
Max. ambient temperature	°C	70	65	65
Starting current	A	1.25	1.2	

ml = Max. load · me = Max. efficiency · fa = Free air · cs = Customer specification · ce = Customer equipment  
Subject to change

## Data according to Commission Regulation (EU) 327/2011

		Actual	Req. 2015
01 Overall efficiency $\eta_{es}$	%	42.5	42.5
02 Measurement category		A	
03 Efficiency category		Static	
04 Efficiency grade N		62	62
05 Variable speed drive		No	

Data obtained at optimum efficiency level.

The ErP data is determined using a motor-impeller combination in a standardized measurement setup.

09 Power consumption $P_e$	kW	0.14
09 Air flow $q_v$	m <sup>3</sup> /h	705
09 Pressure increase $p_{fs}$	Pa	320
10 Speed (rpm) $n$	min <sup>-1</sup>	2560
11 Specific ratio*		1.00

\* Specific ratio =  $1 + p_g / 100\,000\text{ Pa}$

LU-127147



## Technical description

<b>Fan size</b>	225 mm
<b>Rotor surface</b>	Painted black
<b>Impeller material</b>	PA66 plastic, glass-fiber reinforced
<b>Number of blades</b>	7
<b>Direction of rotation</b>	Clockwise, viewed toward rotor
<b>Degree of protection</b>	IP44; installation- and position-dependent as per EN 60034-5
<b>Insulation class</b>	"F"
<b>Moisture (F) / Environmental (H) protection class</b>	H1
<b>Max. permitted ambient temp. for motor (transport/storage)</b>	+ 80 °C
<b>Min. permitted ambient temp. for motor (transport/storage)</b>	- 40 °C
<b>Installation position</b>	Shaft horizontal or rotor on bottom; rotor on top on request
<b>Condensation drainage holes</b>	On rotor side
<b>Mode</b>	S1
<b>Motor bearing</b>	Ball bearing
<b>Touch current according to IEC 60990 (measuring circuit Fig. 4, TN system)</b>	< 0.75 mA
<b>Motor protection</b>	Thermal overload protector (TOP) internally connected
<b>With cable</b>	Variable
<b>Protection class</b>	I (with customer connection of protective earth)
<b>Conformity with standards</b>	EN 60335-1; CE
<b>Approval</b>	UL 1004-3; CSA C22.2 No. 77; EAC

## Product drawing

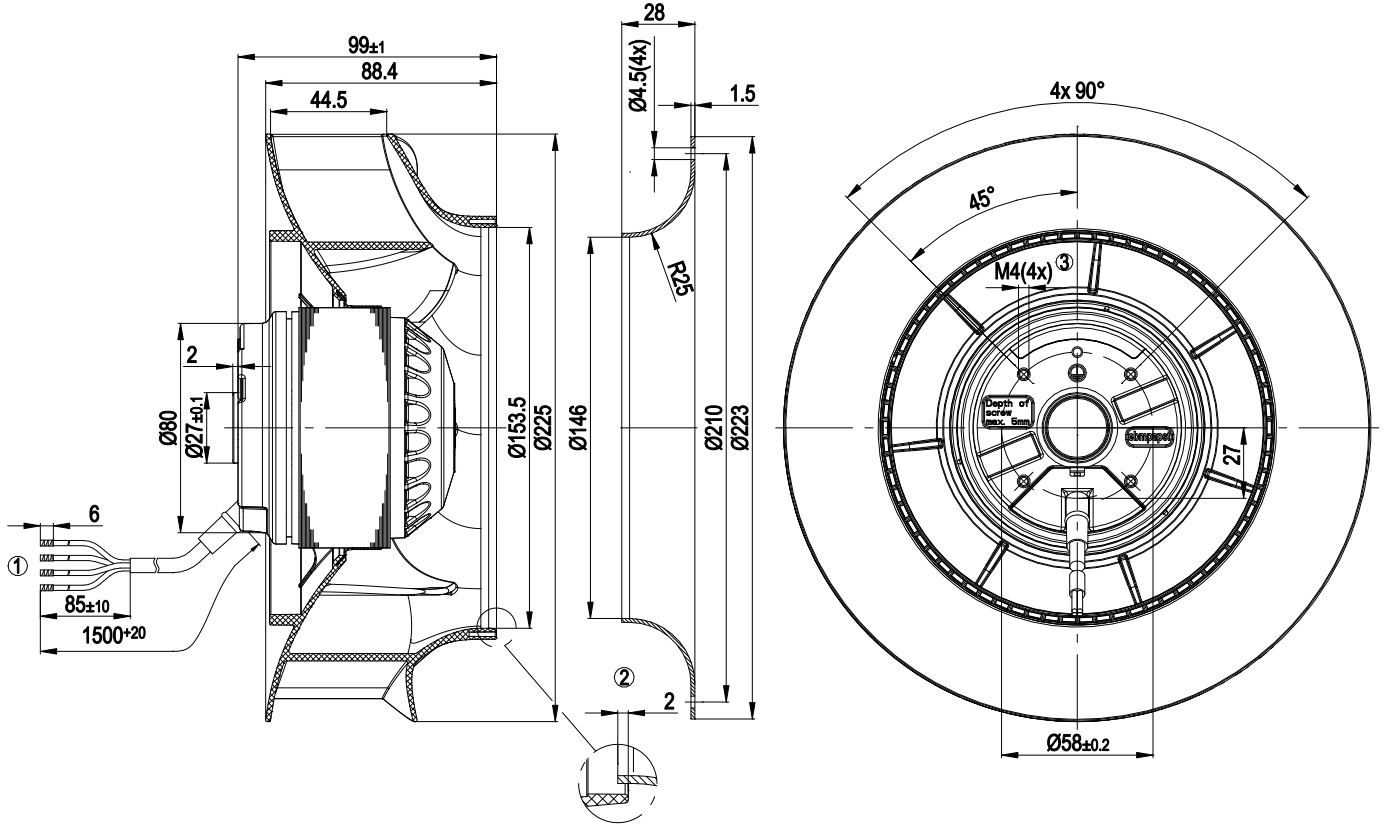

- |   |  |
|---|--|
| 1 | Cable PFA AWG 20, 4x crimped splices                                       |
| 2 | Accessory part: inlet ring 96358-2-4013 not included in scope of delivery. |
| 3 | Max. clearance for screw 5 mm  |

## Connection diagram

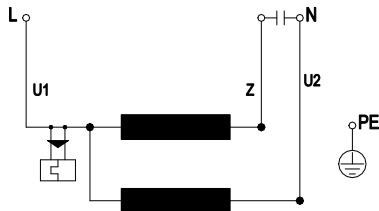

U1	blue	Z	brown	U2	black
PE	green/yellow				

## Curves: Air performance 50 Hz

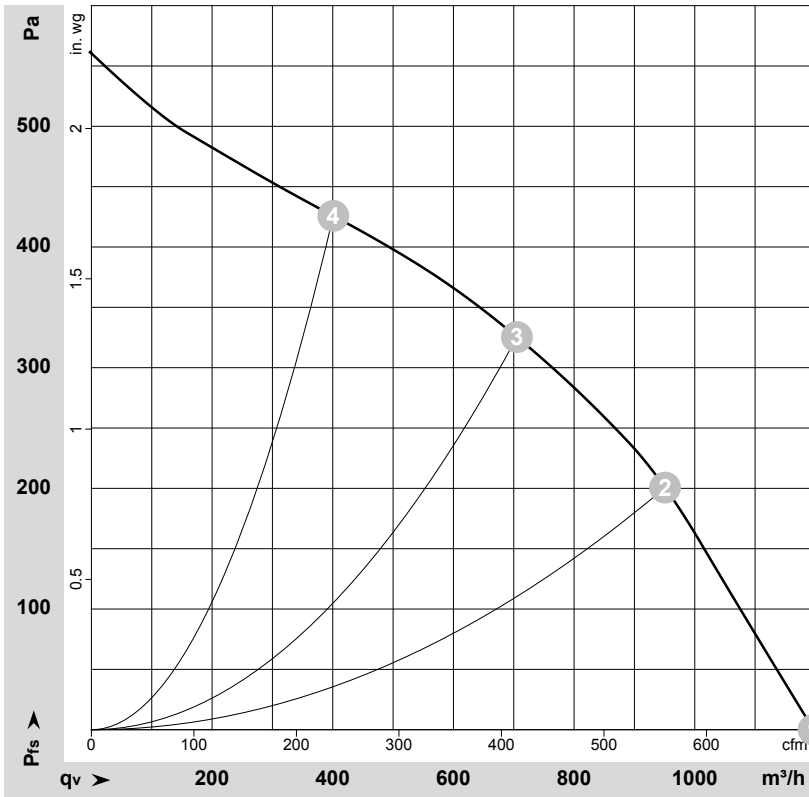

$\rho = 1.15 \text{ kg/m}^3 \pm 2 \%$

Measurement: LU-154575-1

Air performance measured according to ISO 5801 installation category A. For detailed information on the measurement setup, contact ebm-papst. Intake sound level: Sound power level according to ISO 13347 / sound pressure level measured at 1 m distance from fan axis. The values given are valid under the specified measuring conditions and may vary due to conditions of installation. For deviations from the standard configuration, the parameters have to be checked on the installed unit.

## Measured values

	Wired	U	f	n	P <sub>e</sub>	I	LpA <sub>in</sub>	LwA <sub>in</sub>	q <sub>v</sub>	P <sub>fs</sub>	q <sub>v</sub>	P <sub>fs</sub>
		V	Hz	min <sup>-1</sup>	W	A	dB(A)	dB(A)	m <sup>3</sup> /h	Pa	cfm	in. wg
1	1~	230	50	2660	132	0.58	66	73	1195	0	705	0.00
2	1~	230	50	2500	155	0.68	63	70	950	200	560	0.80
3	1~	230	50	2555	150	0.66	58	66	705	325	415	1.30
4	1~	230	50	2625	138	0.60	63	70	400	425	235	1.71

Wired = Wiring · U = Power supply · f = Frequency · n = Speed (rpm) · P<sub>e</sub> = Power consumption · I = Current draw · LpA<sub>in</sub> = Sound pressure level intake side · LwA<sub>in</sub> = Sound power level intake side  
 q<sub>v</sub> = Air flow · P<sub>fs</sub> = Pressure increase

## Curves: Air performance 60 Hz

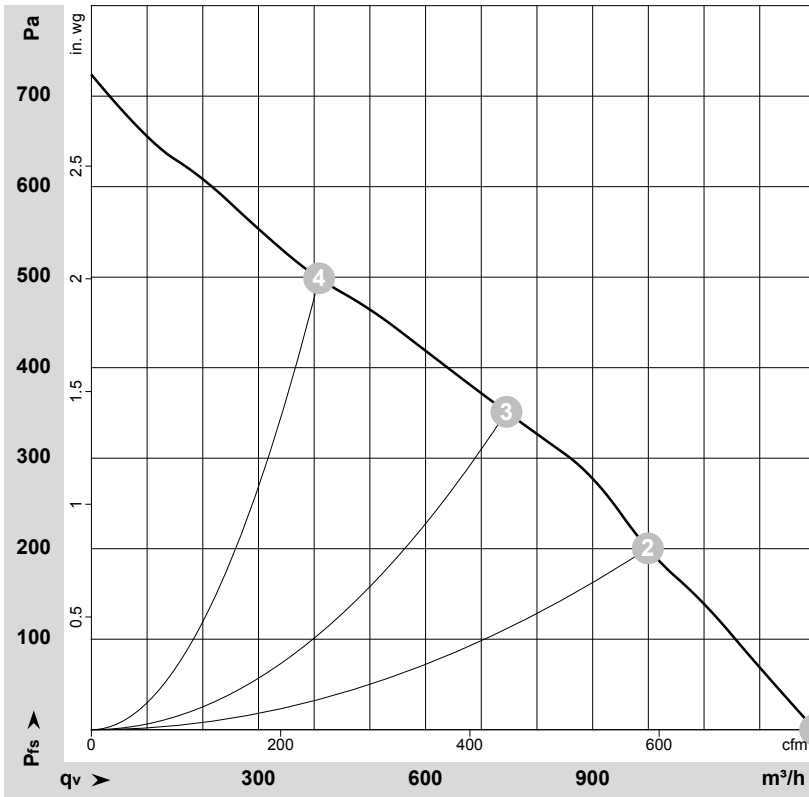

$\rho = 1.15 \text{ kg/m}^3 \pm 2 \%$

Measurement: LU-127148-1

Air performance measured according to ISO 5801 installation category A. For detailed information on the measurement setup, contact ebm-papst. Intake sound level: Sound power level according to ISO 13347 / sound pressure level measured at 1 m distance from fan axis. The values given are valid under the specified measuring conditions and may vary due to conditions of installation. For deviations from the standard configuration, the parameters have to be checked on the installed unit.

## Measured values

	Wired	U	f	n	$P_e$	I	$LpA_{in}$	$LwA_{in}$	$q_v$	$P_{fs}$	$q_v$	$P_{fs}$
		V	Hz	$\text{min}^{-1}$	W	A	dB(A)	dB(A)	$\text{m}^3/\text{h}$	Pa	cfm	in. wg
1	1~	230	60	2930	187	0.81	69	76	1300	0	765	0.00
2	1~	230	60	2700	210	0.92	64	71	1000	200	590	0.80
3	1~	230	60	2700	207	0.90	60	68	745	350	440	1.41
4	1~	230	60	2860	192	0.83	67	75	410	500	240	2.01

Wired = Wiring · U = Power supply · f = Frequency · n = Speed (rpm) ·  $P_e$  = Power consumption · I = Current draw ·  $LpA_{in}$  = Sound pressure level intake side ·  $LwA_{in}$  = Sound power level intake side  
 $q_v$  = Air flow ·  $P_{fs}$  = Pressure increase

