

G1G170-AB53-01

EC centrifugal fan

backward-curved, single-intake
with housing (flange), Gas blower for condensing boilers



ASIA PACIFIC SHENGRUI LIMITED

Phone +00852 56261528

info@apacfan.com

www.apacfan.com

Nominal data

Type	G1G170-AB53-01	
Motor	M1G074-CF	
Phase		1~
Nominal voltage	VAC	230
Frequency	Hz	50/60
Method of obtaining data		fa
Speed (rpm)	min ⁻¹	5830
Power consumption	W	360
Current draw	A	1.6
Min. ambient temperature	°C	-25
Max. ambient temperature	°C	55
Min. temp. of flow medium	°C	-25
Max. temp. of flow medium	°C	80

ml = Max. load · me = Max. efficiency · fa = Free air · cs = Customer specification · ce = Customer equipment
Subject to change

Data according to Commission Regulation (EU) 327/2011

		Actual	Req. 2015
01 Overall efficiency η_{es}	%	58.8	45
02 Measurement category		A	
03 Efficiency category		Static	
04 Efficiency grade N		74.8	61
05 Variable speed drive		Yes	

Data obtained at optimum efficiency level.
The ErP data is determined using a motor-impeller combination in a standardized measurement setup.

09 Power consumption P_{ed}	kW	0.3
09 Air flow q_v	m ³ /h	285
09 Pressure increase p_{fs}	Pa	2000
10 Speed (rpm) n	min ⁻¹	6220
11 Specific ratio*		1.02

* Specific ratio = $1 + p_{fs} / 100\,000$ Pa

LU-57509



EC centrifugal fan

backward-curved, single-intake
with housing (flange), Gas blower for condensing boilers

Technical description

Weight	4.7 kg
Fan size	170 mm
Rotor surface	Painted black
Cover material	Polyflam RPP 374-ND CS1 (UL 97-V0)
Impeller material	Sheet aluminum
Housing material	Die-cast aluminum
Direction of rotation	Clockwise, viewed toward rotor
Degree of protection	IP20
Insulation class	"B"
Moisture (F) / Environmental (H) protection class	H0 - dry environment
Max. permitted ambient temp. for motor (transport/storage)	+80 °C
Min. permitted ambient temp. for motor (transport/storage)	-40 °C
Installation position	Any
Cooling hole/opening	On rotor side
Mode	S1
Premixing	If gas is premixed in the blower, then a special blower must be used. Please consult us about this.
Motor bearing	Ball bearing
Technical features	<ul style="list-style-type: none"> - PFC, active - PWM control input - Motor current limitation - Tach output - Thermal overload protection for motor
EMC immunity to interference	According to EN 61000-6-2 (industrial environment)
EMC circuit feedback	According to EN 61000-3-2/3
EMC interference emission	According to EN 61000-6-4 (industrial environment)
Touch current according to IEC 60990 (measuring circuit Fig. 4, TN system)	<= 3.5 mA
Electrical hookup	With plug
Motor protection	Thermal overload protector (TOP) internally connected
Approval	UL 507; CSA C22.2 No. 113

EC centrifugal fan

backward-curved, single-intake
with housing (flange), Gas blower for condensing boilers

Product drawing

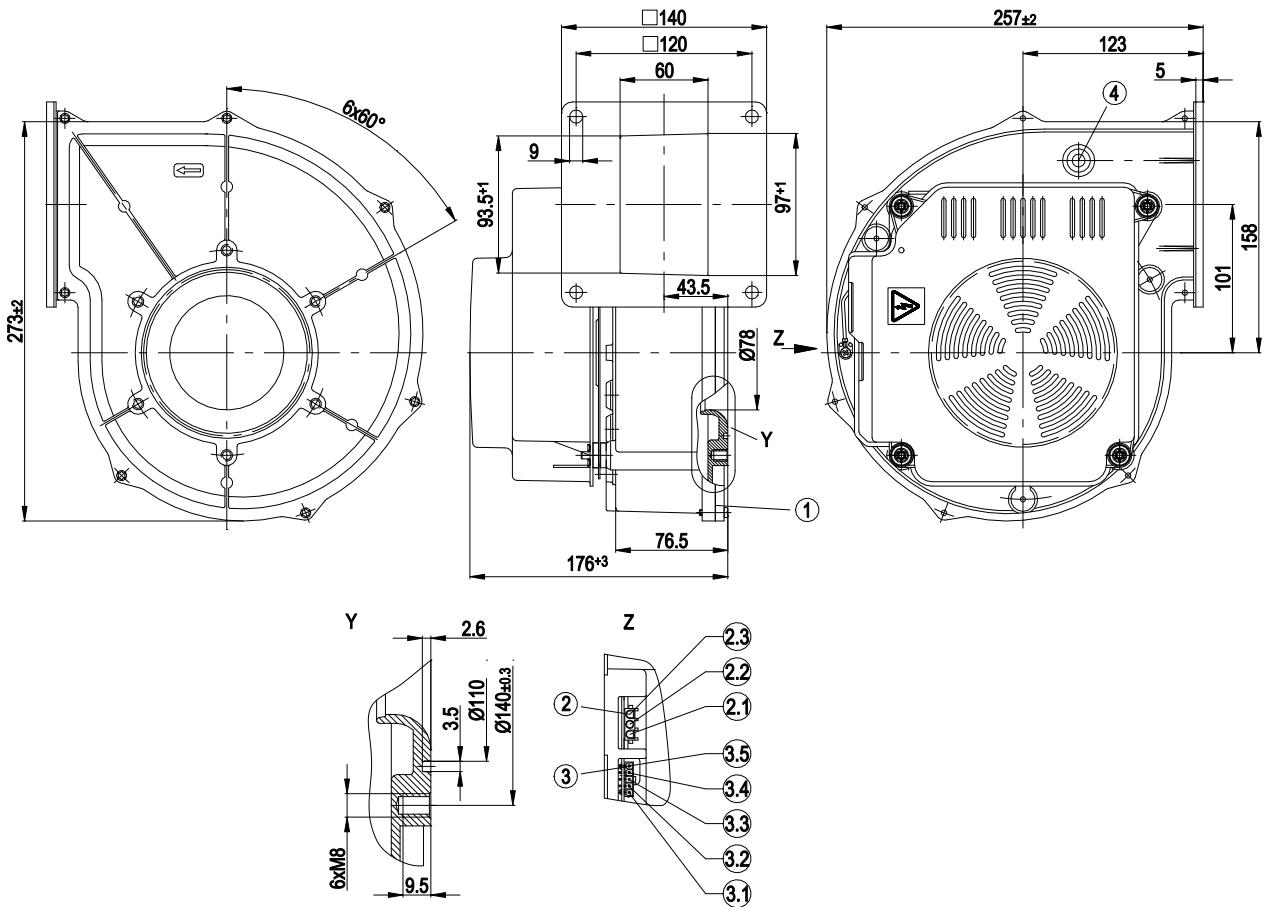

1	Housing side parts sealed with NBR round cord (pentane-resistant)
2	3-pole header, mating connector (not included in scope of delivery): tyco no. 350 766-1, socket: tyco no. 926 884-1
2.1	L
2.2	N
2.3	PE
3	5-pole header; mating connector (not included in scope of delivery): Molex no. 39-01-4050; socket: Molex no. 39-00-0059
3.1	(+)
3.2	Speed monitoring
3.3	not used
3.4	PWM input
3.5	(-)
4	Pressure tap possible
Z	View Z



EC centrifugal fan

backward-curved, single-intake
with housing (flange), Gas blower for condensing boilers

Connection diagram

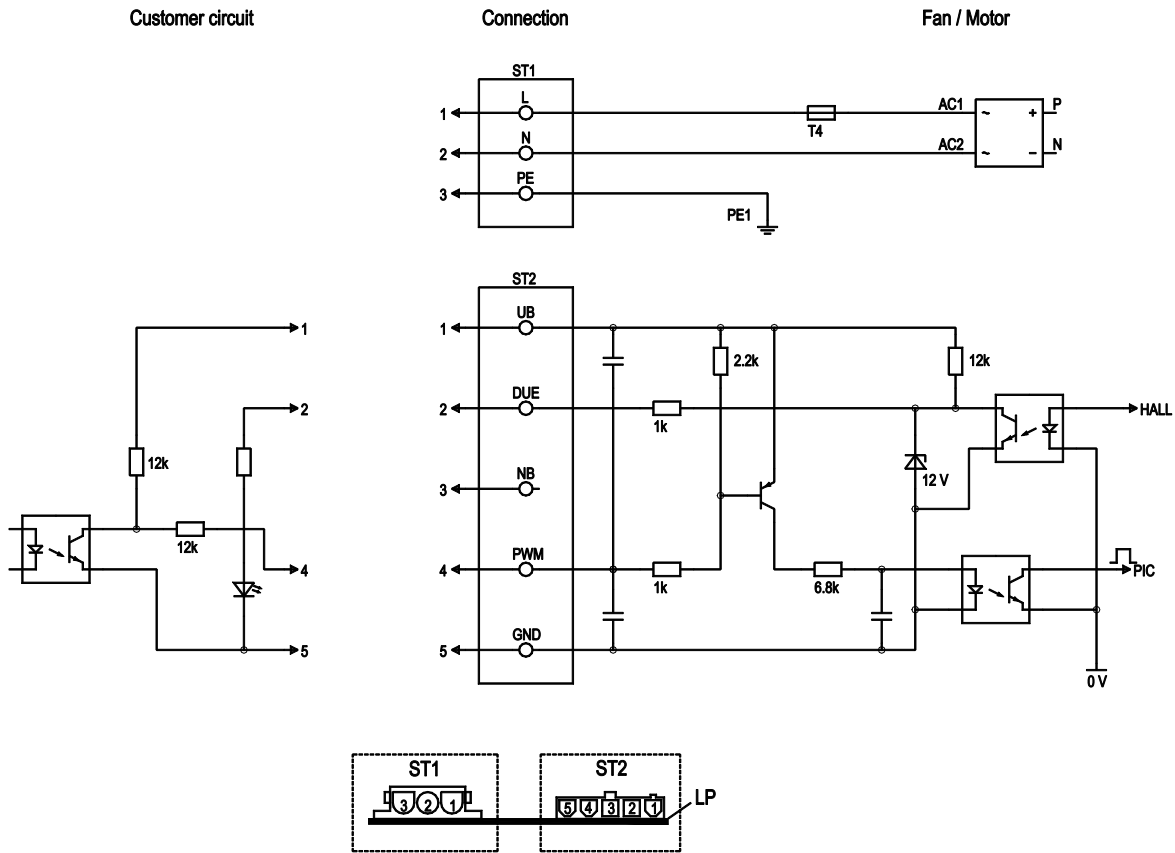

No.	Conn.	Designation	Function/assignment
ST1	1, 2, 3	L, N, PE	Power supply 230 VAC, 50-60 Hz, neutral conductor, protective earth
ST2	1	UB	external voltage 24-45 VDC
ST2	2	Tach	DUE connection, monitoring output, 3 pulses per revolution, Isource 1mA
ST2	3	N.C.	not used
ST2	4	PWM	PWM - 2-6 kHz control input, PWM on n = 100%, PWM low n = 0%
ST2	5	GND	GND connection for control interface

EC centrifugal fan

backward-curved, single-intake

with housing (flange), Gas blower for condensing boilers

Curves: Air performance 50 Hz

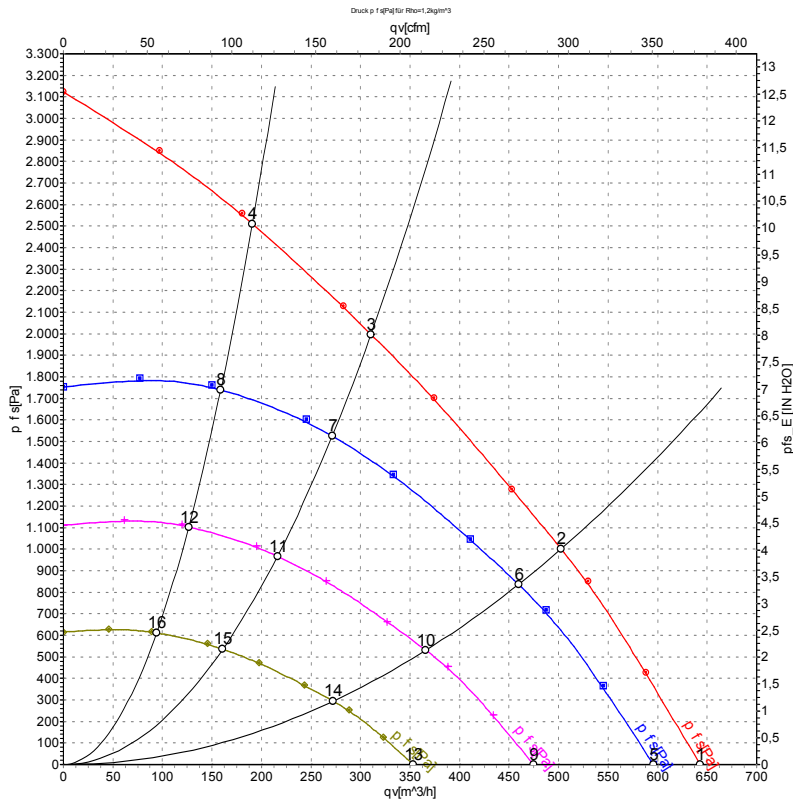

Measurement: LU-57509-1

Air performance measured according to ISO 5801 installation category A. For detailed information on the measurement setup, contact ebm-papst. Intake sound level: Sound power level according to ISO 13347 / sound pressure level measured at 1 m distance from fan axis. The values given are valid under the specified measuring conditions and may vary due to conditions of installation. For deviations from the standard configuration, the parameters have to be checked on the installed unit.

Measured values

	U	f	n	P _{ed}	I	q _V	P _{fs}	q _V	P _{fs}
	V	Hz	min ⁻¹	W	A	m ³ /h	Pa	cfm	inH2O
1	230	50	5830	360	1.60	645	0	380	0.00
2	230	50	5905	346	1.52	505	1000	295	4.01
3	230	50	6175	308	1.35	310	2000	185	8.03
4	230	50	6480	268	1.18	190	2500	110	10.04
5	230	50	5400	287	1.26	595	0	350	0.00
6	230	50	5400	265	1.16	460	838	270	3.36
7	230	50	5400	206	0.91	270	1527	160	6.13
8	230	50	5400	156	0.68	160	1747	95	7.01
9	230	50	4300	145	0.63	475	0	280	0.00
10	230	50	4300	134	0.59	365	531	215	2.13
11	230	50	4300	104	0.46	215	968	125	3.89
12	230	50	4300	79	0.34	125	1108	75	4.45
13	230	50	3200	60	0.26	355	0	210	0.00
14	230	50	3200	55	0.24	270	294	160	1.18
15	230	50	3200	43	0.19	160	536	95	2.15
16	230	50	3200	32	0.14	95	614	55	2.46

U = Power supply · f = Frequency · n = Speed (rpm) · P_{ed} = Power consumption · I = Current draw · q_V = Air flow · p_{fs} = Pressure increase

