

backward curved, single inlet

with support bracket

## ASIA PACIFIC SHENGRUI LIMITED

Phone +00852 56261528

info@apacfan.com

www.apacfan.com



## Nominal data

Type	K3G355-BC92-02	
Motor	M3G112-IA	
Phase		3~
Nominal voltage	VAC	400
Nominal voltage range	VAC	380 .. 480
Frequency	Hz	50/60
Type of data definition		ml
State		prelim.
Speed	min <sup>-1</sup>	2800
Power input	W	2250
Current draw	A	3.5
Min. ambient temperature	°C	-25
Max. ambient temperature	°C	+55

ml = Max. load · me = Max. efficiency · fa = Running at free air · cs = Customer specs · cu = Customer unit  
Subject to alterations

## Data according to ErP directive

Installation category	A
Efficiency category	Static
Variable speed drive	Yes
Specific ratio*	1.01

\* Specific ratio =  $1 + p_{fs} / 100\,000\text{ Pa}$

	Actual	Request 2013	Request 2015
Overall efficiency $\eta_{es}$	63.9	51.2	55.2
Efficiency grade N	70.7	58	62
Power input $P_{ed}$	kW	2.24	
Air flow $q_v$	m <sup>3</sup> /h	4680	
Pressure increase $p_{fs}$	Pa	1038	
Speed n	min <sup>-1</sup>	2825	

Data definition with optimum efficiency.

The ErP data is determined using a motor-impeller combination in a standardised measurement configuration.



## Technical features

Mass	25.4 kg
Size	355 mm
Surface of rotor	Coated in black
Material of electronics housing	Die-cast aluminium
Material of impeller	Aluminium sheet
Material of mounting plate	Sheet steel, galvanised
Material of support bracket	Steel, coated in black
Material of inlet nozzle	Sheet steel, galvanised
Number of blades	7
Direction of rotation	Clockwise, seen on rotor
Type of protection	IP 54
Insulation class	"B"
Humidity class	F4-1
Max. permissible ambient motor temp. (transp./ storage)	+80 °C
Min. permissible ambient motor temp. (transp./storage)	-40 °C
Mounting position	Shaft horizontal or rotor on bottom; rotor on top on request
Condensate discharge holes	Rotor-side
Operation mode	S1
Motor bearing	Ball bearing
Technical features	<ul style="list-style-type: none"> <li>- Output 10 VDC, max. 10 mA</li> <li>- Output 20 VDC, max. 50 mA</li> <li>- Output for slave 0-10 V</li> <li>- Operation and alarm display</li> <li>- Input for sensor 0-10 V or 4-20 mA</li> <li>- External 24 V input (programming)</li> <li>- External release input</li> <li>- Alarm relay</li> <li>- Integrated PID controller</li> <li>- Motor current limit</li> <li>- PFC, passive</li> <li>- RS485 MODBUS RTU</li> <li>- Soft start</li> <li>- Control input 0-10 VDC / PWM</li> <li>- Control interface with SELV potential safely disconnected from the mains</li> <li>- Over-temperature protected electronics / motor</li> <li>- Line undervoltage / phase failure detection</li> </ul>
EMC interference immunity	Acc. to EN 61000-6-2 (industrial environment)
EMC interference emission	Acc. to EN 61000-6-3 (household environment)
Touch current acc. IEC 60990 (measuring network Fig. 4, TN system)	<= 3.5 mA
Electrical leads	Via terminal box
Motor protection	Thermal overload protector (TOP) wired internally
Protection class	I (if protective earth is connected by customer)
Product conforming to standard	EN 61800-5-1; CE
Approval	UL 1004-7 + 60730; GOST

# EC centrifugal module - RadiPac

backward curved, single inlet  
with support bracket

## Product drawing

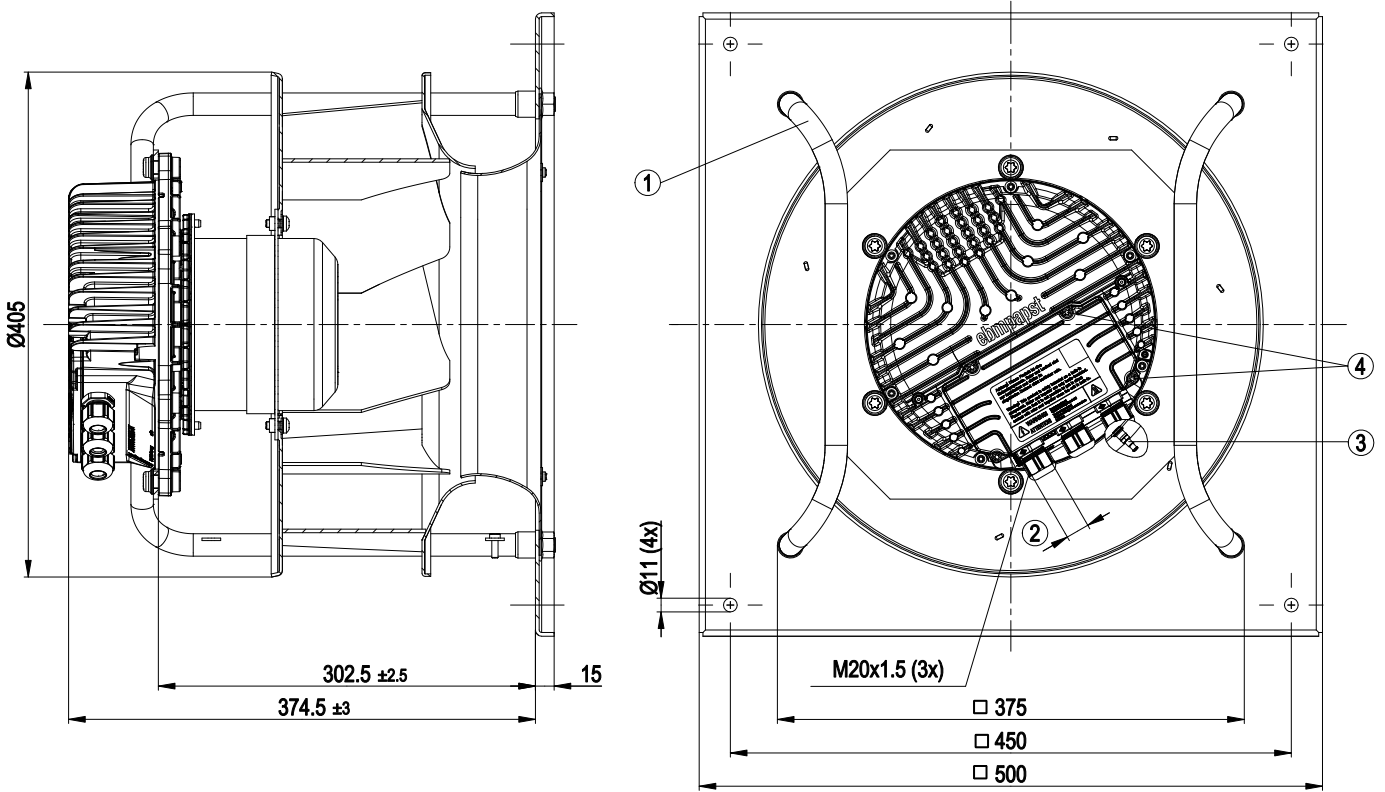

1	Mounting position: shaft horizontal (install the support struts only vertically as shown in the view!) or rotor on bottom; rotor on top on request
2	Cable diameter: min. 4 mm, max. 10 mm, tightening torque: 4±0.6 Nm
3	Inlet nozzle with bleeder connection for pressure relief (k-factor: 148)
4	Tightening torque 3.5±0.5 Nm



# EC centrifugal module - RadiPac

backward curved, single inlet  
with support bracket

## Connection screen

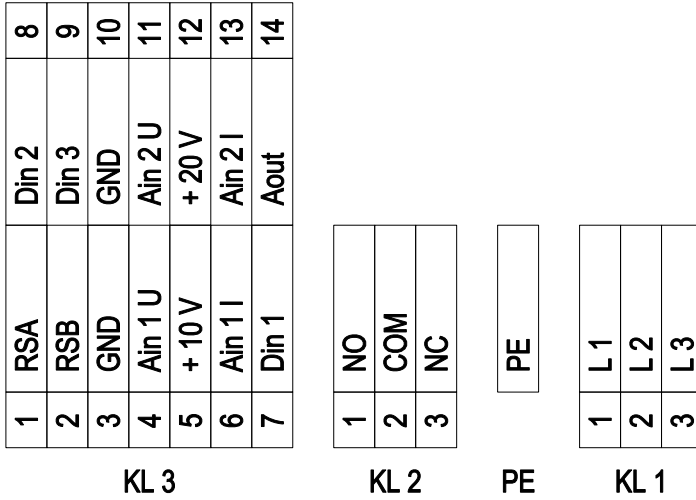

No.	Pin	Signal	Function / assignment
KL 1	1	L1	Mains supply connection, supply voltage 3~380-480 VAC; 50/60 Hz
KL 1	2	L2	Mains supply connection, supply voltage 3~380-480 VAC; 50/60 Hz
KL 1	3	L3	Mains supply connection, supply voltage 3~380-480 VAC; 50/60 Hz
PE		PE	Earth connection, PE connection
KL 2	1	NO	Status relay, floating status contact; normally open; close with error
KL2	2	COM	Status relay; floating status contact; changeover contact; common connection; contact rating 250 VAC / max. 2 A (AC1) / min. 10 mA
KL2	3	NC	Status relay, floating status contact; break with error
KL 3	1	RSA	Bus connection RS485; RSA; MODBUS RTU
KL 3	2	RSB	Bus connection RS485; RSB; MODBUS RTU
KL 3	3 / 10	GND	Signal ground for control interface KL3
KL 3	4	Ain1 U	Analogue input 1 (set value); 0-10 V; Ri= 100 kΩ; parametrisable curves; only usable as alternative to input Ain1 I
KL 3	5	+ 10 V	Fixed voltage output 10 VDC; + 10 V +/-3%; max. 10 mA; short circuit proof; power supply for ext. devices (e.g. potentiometer)
KL 3	6	Ain1 I	Analogue input 1 (set value); 4-20 mA; Ri= 100 Ω; parametrisable curves; only usable as alternative to input Ain1 U
KL 3	7	Din1	Digital input 1: enabling of electronics; enabling: open pin or applied voltage 5 to 50 VDC; disabling: bridge to GND or applied voltage < 1 VDC; reset function: triggers software reset after a level change to <1 V
KL 3	8	Din2	Digital input 2: parameter set switch 1/2; according to EEPROM setting, the valid/used parameter set is selectable per BUS or per digital input DIN2. Parameter set 1: open pin or applied voltage 5 to 50 VDC; parameter set 2: bridge to GND or applied voltage < 1 VDC
KL 3	9	Din3	Digital input 3: Control characteristic of the integrated controller; according to EEPROM setting, the control characteristic of the integrated controller is normally/inversely selectable per BUS or per digital input; normal: open pin or applied voltage 5 to 50 VDC (control deviation = actual sensor value - set value) inverse: bridge to GND or applied voltage < 1 VDC (control deviation = set value - actual sensor value)
KL 3	11	Ain2 U	Analogue input 2; actual sensor value 0-10 V; Ri= 100 kΩ; parametrisable curve; only usable as alternative to input Ain2 I
KL 3	12	+ 20 V	Fixed voltage output 20 VDC; + 20 V +/-10 %; max. 50 mA; short circuit proof; power supply for ext. devices (e.g. sensors)
KL 3	13	Ain2 I	Analogue input 2; actual sensor value 4-20 mA; Ri= 100 Ω; parametrisable curve; only usable as alternative to input Ain2 U
KL 3	14	Aout	Analogue output 0-10 V; max. 5 mA; output of the actual motor control factor (output voltage of electronics)/ of the actual motor speed; function selectable per bus; parametrisable curve.



# EC centrifugal module - RadiPac

backward curved, single inlet  
with support bracket

## Charts: Air flow 50 Hz

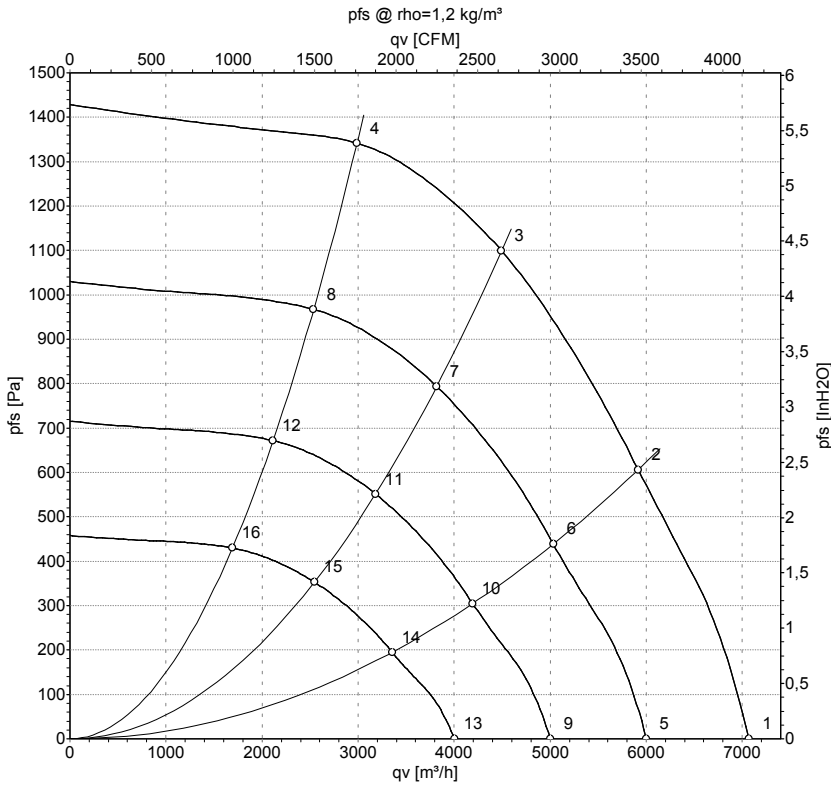

Measurement: LU-149893

Air performance measured as per ISO 5801 Installation category A. For detailed information on the measuring set-up, please contact ebm-papst. Suction-side noise levels: LwA measured as per ISO 13347 / LpA measured with 1m distance to fan axis. The values given are valid under the measuring conditions mentioned above and may vary according to the actual installation situation. With any deviation from the standard set-up, the specific values have to be checked and reviewed with the unit installed.

## Measured values

	U	f	n	P <sub>ed</sub>	I	LpA <sub>in</sub>	LwA <sub>in</sub>	LwA <sub>out</sub>	qv	p <sub>fs</sub>
	V	Hz	min <sup>-1</sup>	W	A	dB(A)	dB(A)	dB(A)	m <sup>3</sup> /h	Pa
1	400	50	2800	1463	2.33	82	90	96	7070	0
2	400	50	2800	1916	2.99	79	86	92	5915	600
3	400	50	2800	2250	3.50	78	85	90	4495	1100
4	400	50	2800	2134	3.29	79	88	93	2985	1350
5	400	50	2400	896	1.43	78	86	92	6000	0
6	400	50	2400	1179	1.84	75	82	88	5030	438
7	400	50	2400	1379	2.12	73	81	86	3820	796
8	400	50	2400	1305	2.01	75	84	89	2535	972
9	400	50	2000	518	0.82	73	81	87	5000	0
10	400	50	2000	682	1.07	70	77	84	4195	304
11	400	50	2000	798	1.23	69	76	82	3185	553
12	400	50	2000	755	1.16	71	79	84	2115	675
13	400	50	1600	265	0.42	68	76	81	4000	0
14	400	50	1600	349	0.55	64	72	78	3355	195
15	400	50	1600	409	0.63	63	70	76	2545	354
16	400	50	1600	387	0.60	65	74	78	1690	432

U = Supply voltage · f = Frequency · n = Speed · P<sub>ed</sub> = Power input · I = Current draw · LpA<sub>in</sub> = Sound pressure level inlet side · LwA<sub>in</sub> = Sound power level inlet side · LwA<sub>out</sub> = Sound power level outlet side  
qv = Air flow · p<sub>fs</sub> = Pressure increase

