

R3G630-RA38-76

Stulz GmbH

EC centrifugal fan - RadiCal

backward-curved, single-intake

ASIA PACIFIC SHENGRUI LIMITED

Phone +00852 56261528

info@apacfan.com

www.apacfan.com



Nominal data

Type	R3G630-RA38-76	
Motor	M3G150-FF	
Phase		3~
Nominal voltage	VAC	400
Nominal voltage range	VAC	380 .. 480
Frequency	Hz	50/60
Method of obtaining data		ml
Status		prelim.
Speed (rpm)	min ⁻¹	1240-1300
Power consumption	W	2500
Current draw	A	3.8
Min. ambient temperature	°C	-25
Max. ambient temperature	°C	40

ml = Max. load · me = Max. efficiency · fa = Free air · cs = Customer specification · ce = Customer equipment
Subject to change

Data according to ErP Directive

		Actual	Req. 2015			
01 Overall efficiency η_{es}	%	64.5	55.6	09 Power consumption P_{ed}	kW	2.46
02 Measurement category		A		09 Air flow q_v	m ³ /h	10750
03 Efficiency category		Static		09 Pressure increase p_{fs}	Pa	501
04 Efficiency grade N		70.9	62	10 Speed (rpm) n	min ⁻¹	1240
05 Variable speed drive		Yes		11 Specific ratio*		1.01

Data obtained at optimum efficiency level.

The ErP data is determined using a motor-impeller combination in a standardized measurement setup.

* Specific ratio = $1 + p_{fs} / 100\,000\text{ Pa}$

LU-172357



Technical description

Weight	29 kg
Fan size	630 mm
Rotor surface	Painted black
Electronics housing material	Die-cast aluminum
Impeller material	PP plastic
Number of blades	6
Direction of rotation	Clockwise, viewed toward rotor
Degree of protection	IP55
Insulation class	"F"
Moisture (F) / Environmental (H) protection class	H1
Max. permitted ambient temp. for motor (transport/storage)	+80 °C
Min. permitted ambient temp. for motor (transport/storage)	-40 °C
Installation position	Shaft horizontal or rotor on bottom
Condensation drainage holes	On rotor side
Mode	S1
Motor bearing	Ball bearing
Technical features	<ul style="list-style-type: none"> - Output 10 VDC, max. 10 mA - Operation and alarm display - External 24 V input (parameter setting) - External release input - Alarm relay - Integrated PID controller - Power limiter - Motor current limitation - PFC, passive - RS-485 MODBUS-RTU - Soft start - EEPROM write cycles: 100,000 maximum - Control input 0-10 VDC / PWM - Control interface with SELV potential safely disconnected from the mains - Thermal overload protection for electronics/motor - Line undervoltage detection
Touch current according to IEC 60990 (measuring circuit Fig. 4, TN system)	<= 3.5 mA
Electrical hookup	With plug
Motor protection	Reverse polarity and locked-rotor protection
With cable	Lateral
Protection class	I (with customer connection of protective earth)
Conformity with standards	EN 61800-5-1; CE
Approval	EAC

Product drawing

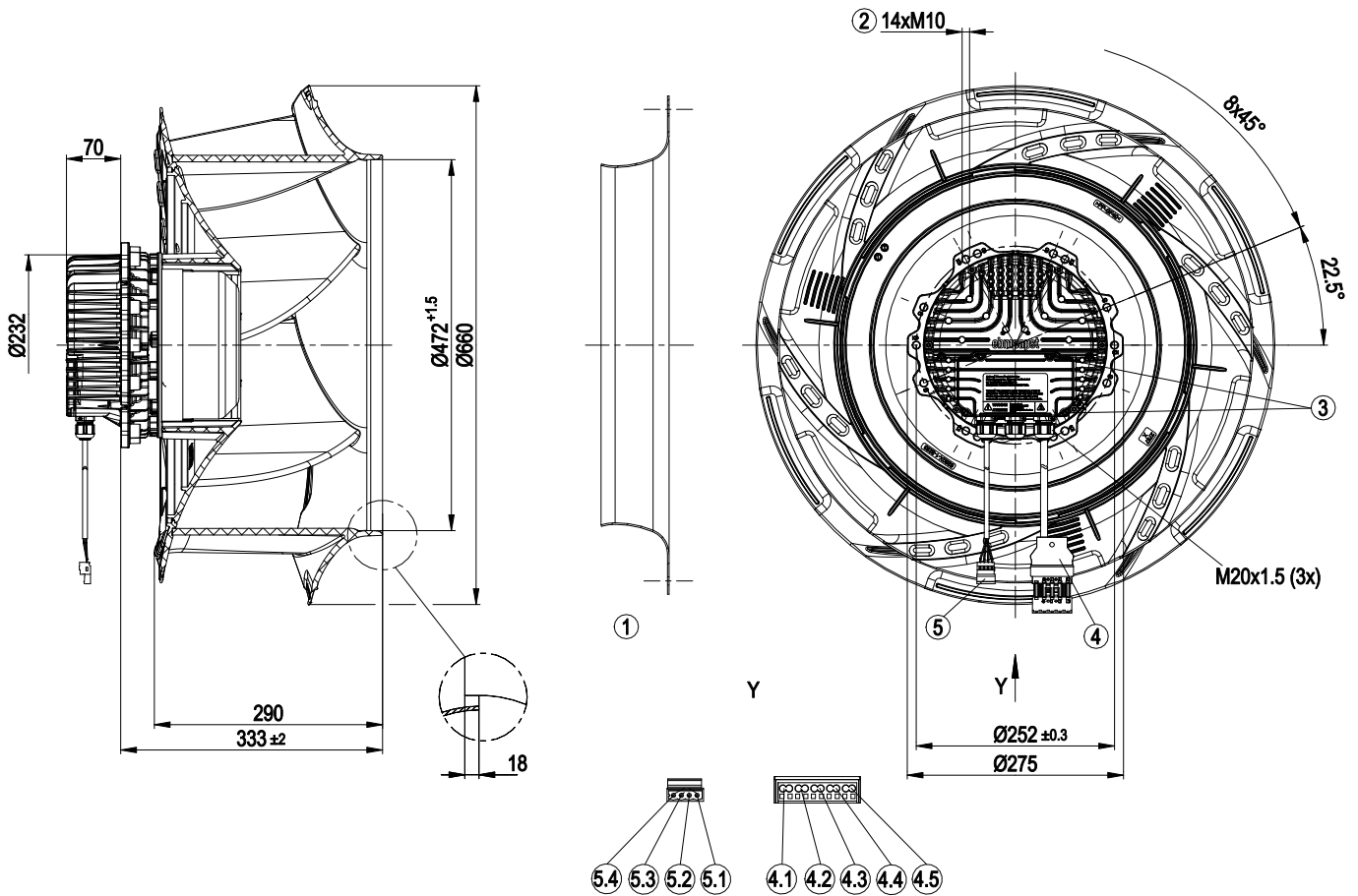

1	Accessory part: inlet ring 63300-2-4013 not included in scope of delivery
2	Max. clearance for screw 25 mm
3	Tightening torque 3.5 ± 0.5 Nm
Y	View Y
4	Plug WAGO no. 0770-001/K011-0174/0000-0300, mating connector (not included in scope of delivery), cable Ölflex Classic 110 gray 4G2.5 with GNYE
4.1	not used
4.2	PE
4.3	L1
4.4	L2
4.5	L3
5	4-pole header, contact spacing 5, WAGO no. 231-604, mating connector (not included), cable Ölflex Classic 110 gray 4x 0.75 without GNYE
5.1	GND
5.2	0 - 10 V / PWM
5.3	C
5.4	NC

Accessory part

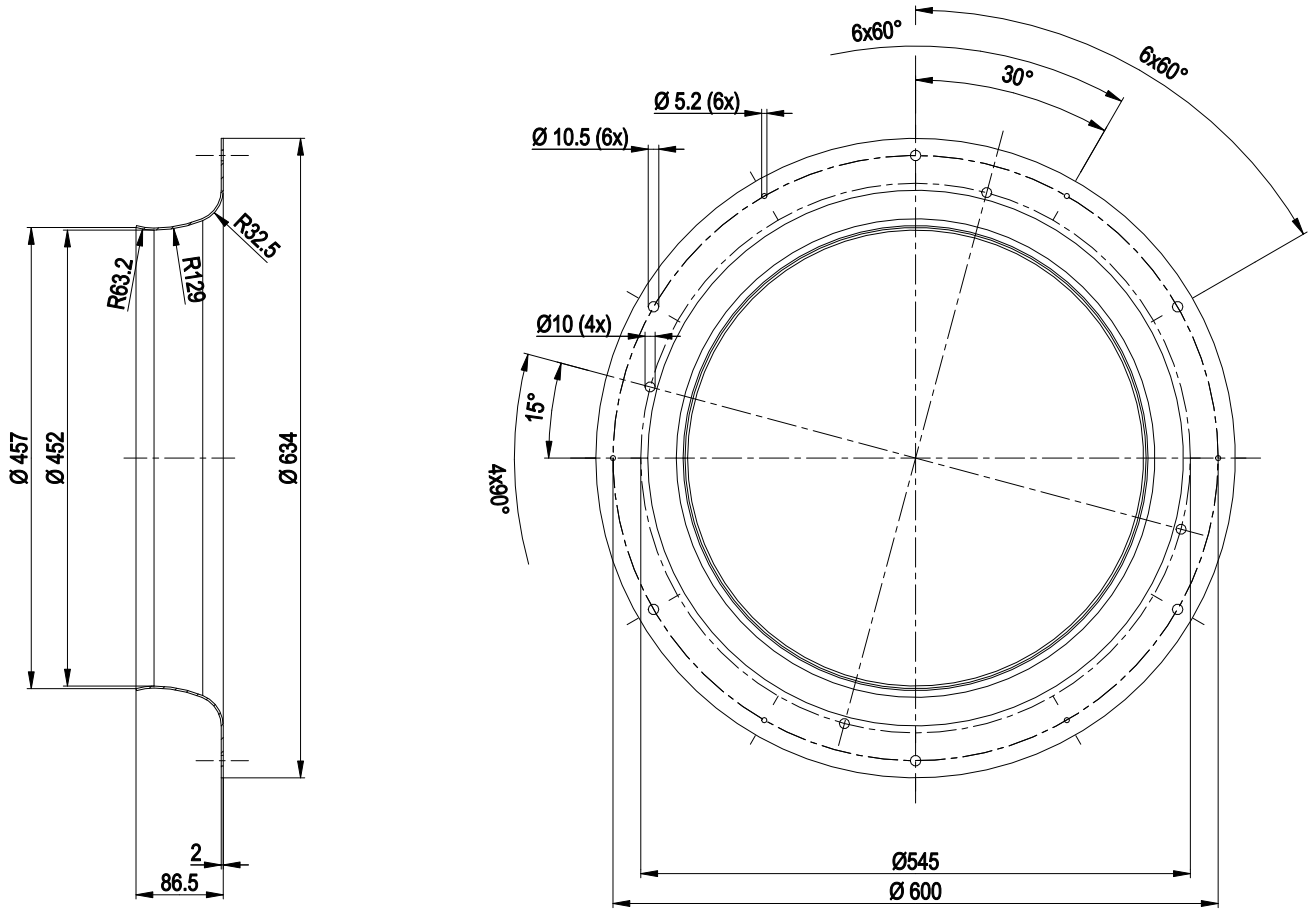

Accessory part: inlet ring 63300-2-4013 not included in scope of delivery

Connection diagram

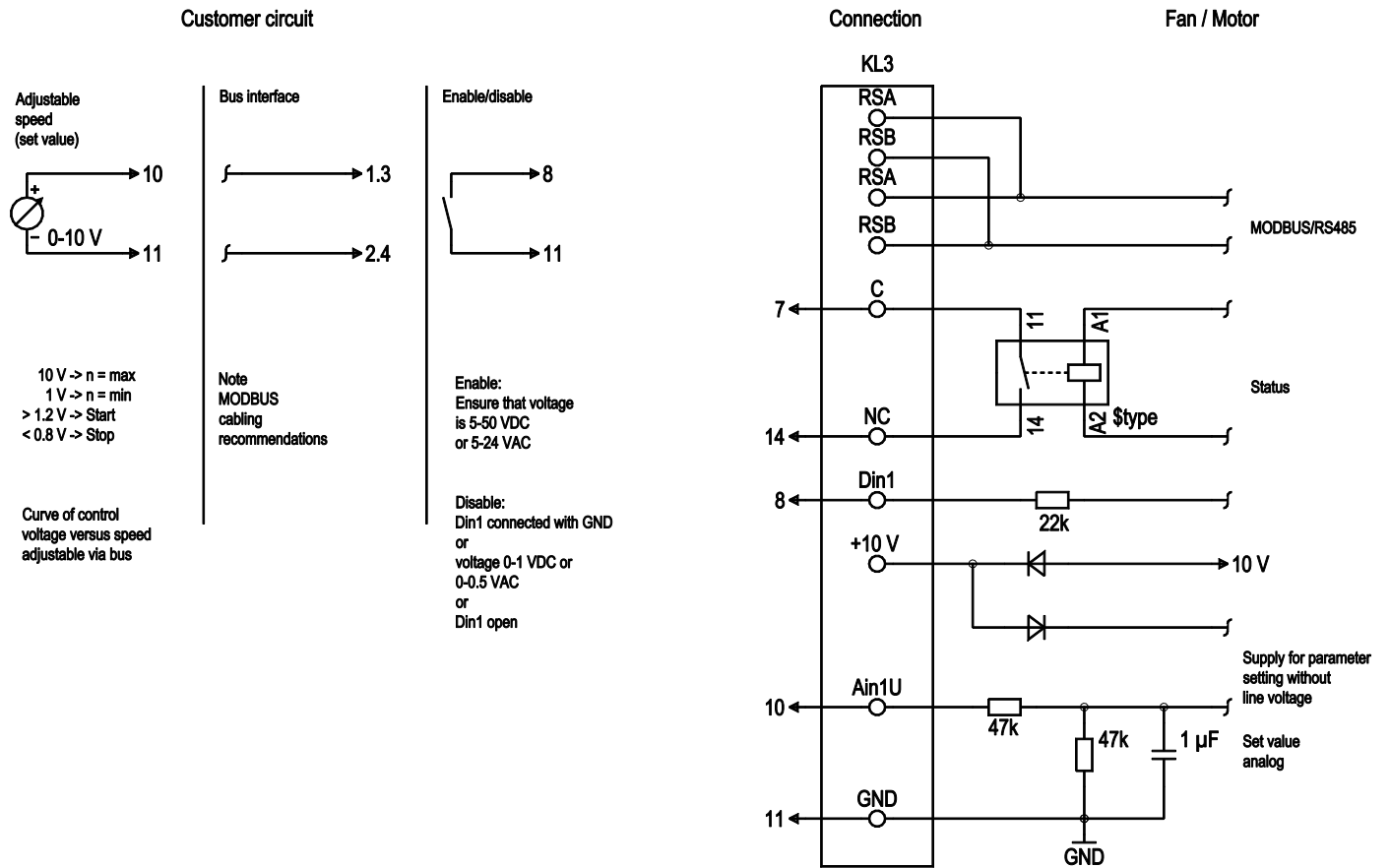

Terminal box connection diagram

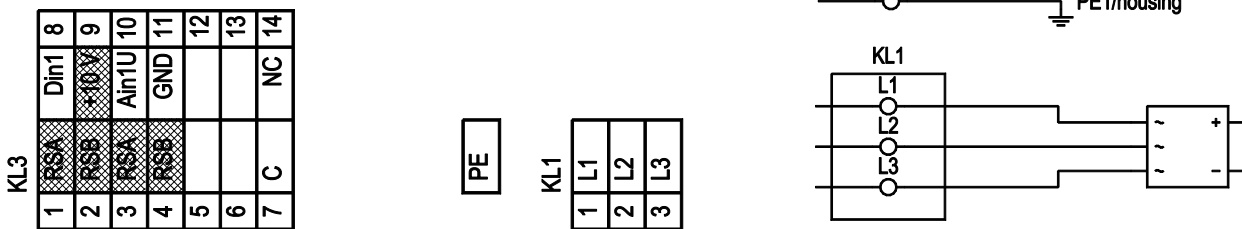

shaded gray => not brought out via leads

No.	Conn.	Designation	Function/assignment
KL1	1, 2, 3	L1, L2, L3	Supply connection, power supply; for nominal voltage range see technical data
PE	PE	PE	Ground connection, PE connection
KL3	7	C	Status relay, floating status contact, break for failure; contact rating 250 VAC / max. 2 A (AC1) / min. 10 mA
KL3	14	NC	Status relay, floating status contact, break for failure; contact rating 250 VAC / max. 2 A (AC1) / min. 10 mA
KL3	1.3	RSA	Bus connection RS485, RSA, MODBUS-RTU; SELV
KL3	2, 4	RSB	Bus connection RS485, RSB, MODBUS-RTU; SELV
KL3	11	GND	Reference ground for control interface; SELV
KL3	10	Ain1 U	Analog input 1, set value: 0-10 V, Ri = 100 kΩ, adjustable curve, only usable as alternative to input Ain1 I; SELV
KL3	9	+10 V	Fixed voltage output 10 VDC, +10 V ±3%, max. 10 mA, short-circuit-proof, power supply for external devices (e.g. pot); SELV

R3G630-RA38-76

Stulz GmbH

EC centrifugal fan - RadiCal

backward-curved, single-intake

No.	Conn.	Designation	Function/assignment
KL3	8	Din1	Digital input 1: enable electronics; SELV Enable -> 5-50 VDC / 5-24 VAC Disable -> 0-1 VDC / 0-0.5 VAC or bridge to GND or open



Curves: Air performance 50 Hz

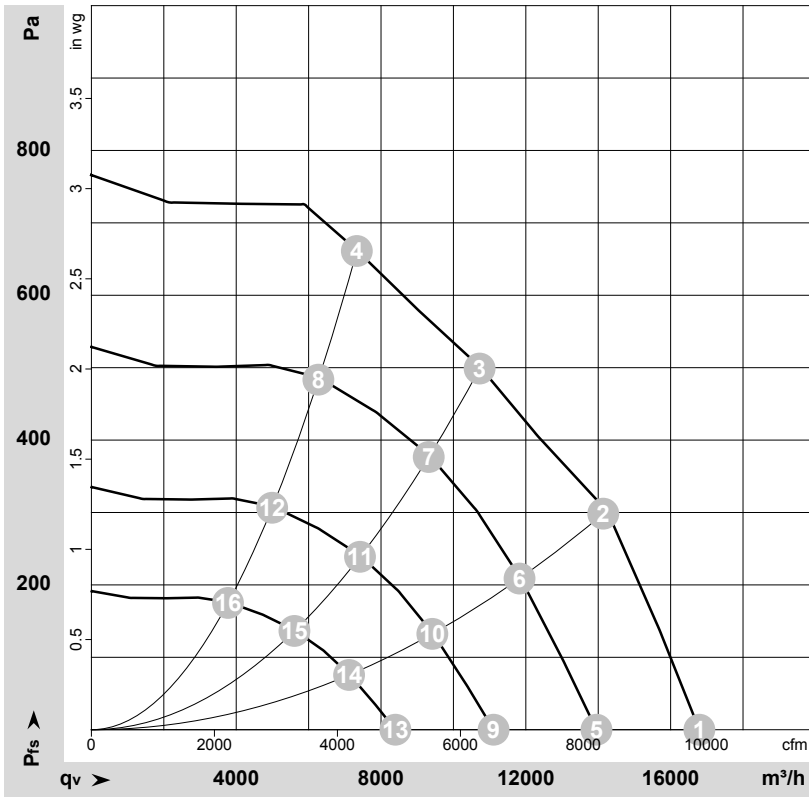

$\rho = 1.15 \text{ kg/m}^3 \pm 2 \%$

Measurement: LU-172357-1

Air performance measured according to ISO 5801 installation category A. For detailed information on the measurement setup, contact ebmpapst. Intake sound level: Sound power level according to ISO 13347 / sound pressure level measured at 1 m distance from fan axis. The values given are valid under the specified measuring conditions and may vary due to conditions of installation. For deviations from the standard configuration, the parameters have to be checked on the installed unit.

Measured values

	Wired	U	f	n	P _{ed}	I	LpA _{in}	LwA _{in}	LwA _{out}	qv	p _{fs}	qv	p _{fs}
		V	Hz	min ⁻¹	W	A	dB(A)	dB(A)	dB(A)	m ³ /h	Pa	CFM	inH ₂ O
1	Y	400	50	1300	1805	2.84	80	88	92	16795	0	9885	0.00
2	Y	400	50	1295	2465	3.80	74	82	87	14140	300	8320	1.20
3	Y	400	50	1240	2465	3.80	70	77	82	10725	500	6310	2.01
4	Y	400	50	1260	2465	3.80	72	79	84	7330	660	4315	2.65
5	Y	400	50	1080	1035	1.63	76	83	87	13950	0	8210	0.00
6	Y	400	50	1080	1425	2.20	70	77	82	11825	211	6960	0.85
7	Y	400	50	1080	1620	2.51	66	74	79	9320	380	5485	1.53
8	Y	400	50	1080	1549	2.39	68	75	80	6270	487	3690	1.96
9	Y	400	50	860	523	0.82	70	77	82	11110	0	6540	0.00
10	Y	400	50	860	719	1.11	64	71	77	9415	134	5545	0.54
11	Y	400	50	860	818	1.26	61	68	73	7420	241	4365	0.97
12	Y	400	50	860	782	1.21	63	70	75	4995	309	2940	1.24
13	Y	400	50	650	226	0.35	63	70	74	8395	0	4940	0.00
14	Y	400	50	650	311	0.48	57	64	70	7120	77	4190	0.31
15	Y	400	50	650	353	0.55	53	61	66	5610	137	3300	0.55
16	Y	400	50	650	338	0.52	56	63	67	3775	176	2220	0.71

Wired = Wiring · U = Power supply · f = Frequency · n = Speed (rpm) · P_{ed} = Power consumption · I = Current draw · LpA_{in} = Sound pressure level intake side · LwA_{in} = Sound power level intake side
 LwA_{out} = Sound power level outlet side · qv = Air flow · p_{fs} = Pressure increase

