

## ASIA PACIFIC SHENGRUI LIMITED

Phone +00852 56261528

info@apacfan.com

www.apacfan.com

## Nominal data

Type	R3G630-RB32-65	
Motor	M3G150-IF	
Phase		3~
Nominal voltage	VAC	400
Nominal voltage range	VAC	380 .. 480
Frequency	Hz	50/60
Method of obtaining data		ml
Status		prelim.
Speed (rpm)	min <sup>-1</sup>	1370
Power consumption	W	3250
Current draw	A	5.0
Min. ambient temperature	°C	-25
Max. ambient temperature	°C	40

ml = Max. load · me = Max. efficiency · fa = Free air · cs = Customer specification · ce = Customer equipment  
Subject to change

## Data according to Commission Regulation (EU) 327/2011

		Actual	Req. 2015			
01 Overall efficiency $\eta_{es}$	%	64.3	56.9	09 Power consumption $P_{ed}$	kW	3.25
02 Measurement category		A		09 Air flow $q_v$	m <sup>3</sup> /h	11710
03 Efficiency category		Static		09 Pressure increase $p_{fs}$	Pa	614
04 Efficiency grade N		69.4	62	10 Speed (rpm) n	min <sup>-1</sup>	1370
05 Variable speed drive		Yes		11 Specific ratio*		1.01

Data obtained at optimum efficiency level.

The ErP data is determined using a motor-impeller combination in a standardized measurement setup.

\* Specific ratio =  $1 + p_{fs} / 100\,000\text{ Pa}$

LU-188195



## Technical description

Weight	31 kg
Size	630 mm
Motor size	150
Rotor surface	Painted black
Electronics housing material	Die-cast aluminum
Impeller material	PP plastic
Number of blades	6
Direction of rotation	Clockwise, viewed toward rotor
Degree of protection	IP55
Insulation class	"F"
Moisture (F) / Environmental (H) protection class	H1
Max. permitted ambient temp. for motor (transport/storage)	+80 °C
Min. permitted ambient temp. for motor (transport/storage)	-40 °C
Installation position	Shaft horizontal or rotor on bottom; rotor on top on request
Condensation drainage holes	On rotor side
Mode	S1
Motor mounting	Ball bearing
Technical features	<ul style="list-style-type: none"> <li>- Output 10 VDC, max. 10 mA</li> <li>- Operation and alarm display</li> <li>- External 24 V input (parameter setting)</li> <li>- External release input</li> <li>- Alarm relay</li> <li>- Integrated PID controller</li> <li>- Motor current limitation</li> <li>- PFC, passive</li> <li>- RS-485 MODBUS-RTU</li> <li>- Soft start</li> <li>- Control input 0-10 VDC / PWM</li> <li>- Control interface with SELV potential safely disconnected from the mains</li> <li>- Thermal overload protection for electronics/motor</li> <li>- Line undervoltage / phase failure detection</li> </ul>
Touch current according to IEC 60990 (measuring circuit Fig. 4, TN system)	<= 3.5 mA
Electrical hookup	Terminal box
Motor protection	Reverse polarity and locked-rotor protection
Protection class	I (with customer connection of protective earth)
Conformity with standards	EN 61800-5-1; CE
Approval	EAC

# EC centrifugal fan

backward-curved, single-intake

## Product drawing

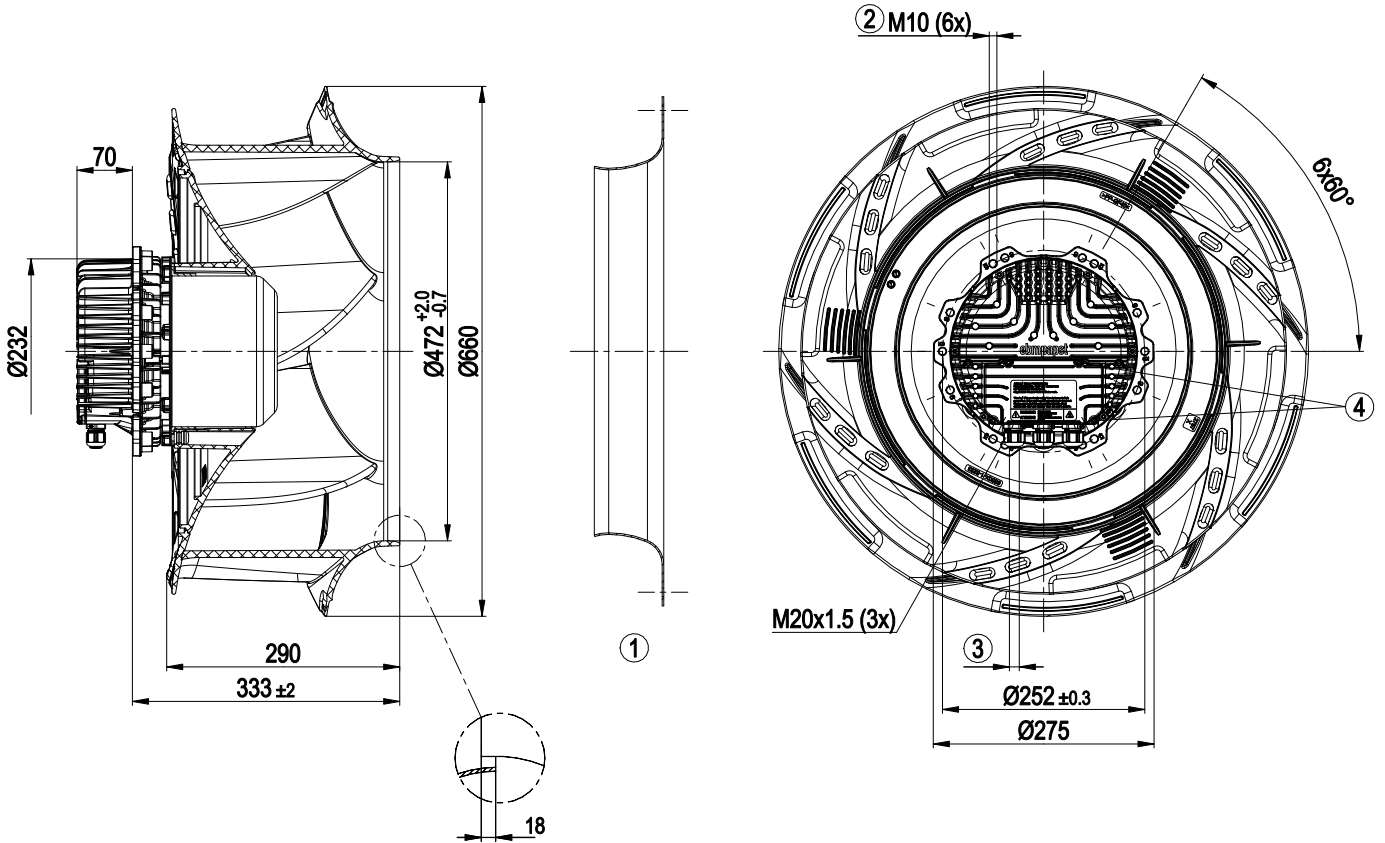

1	Accessory part: inlet ring 63300-2-4013 not included in scope of delivery
2	Max. clearance for screw 25 mm
3	Cable diameter min. 4 mm, max. 10 mm, tightening torque $4 \pm 0.6$ Nm
4	Tightening torque $3.5 \pm 0.5$ Nm

## Accessory part

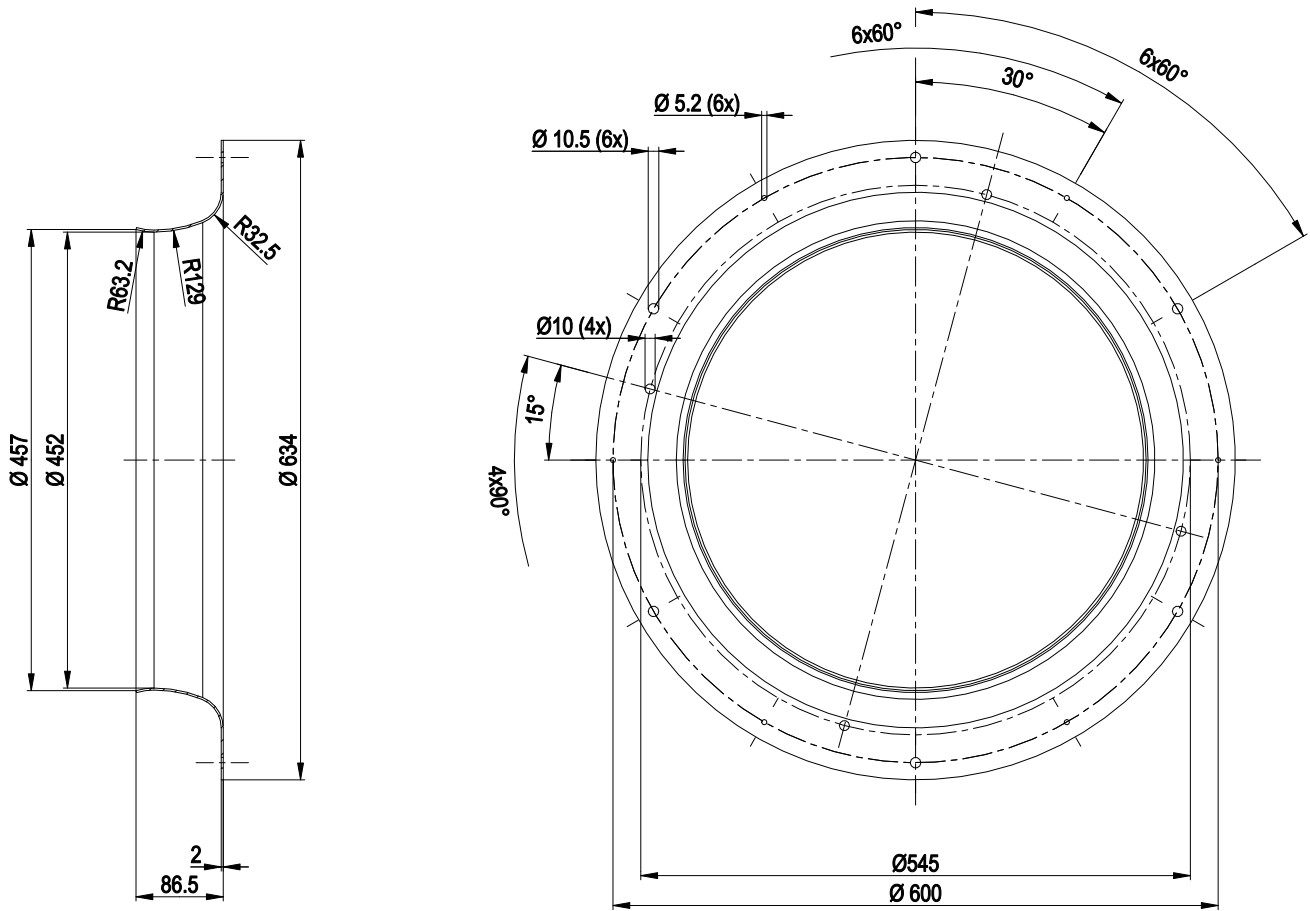

Accessory part: inlet ring 63300-2-4013 not included in scope of delivery

# EC centrifugal fan

backward-curved, single-intake

## Connection diagram

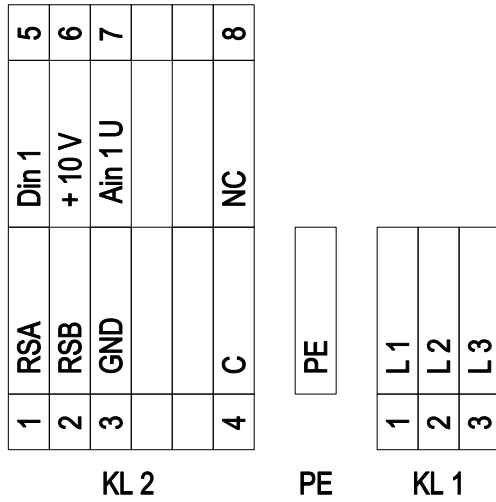

No.	Conn.	Designation	Function/assignment
KL 1	1	L1	Supply connection, power supply 3-phase 380-480 VAC, 50/60 Hz
KL 1	2	L2	Supply connection, power supply 3-phase 380-480 VAC, 50/60 Hz
KL 1	3	L3	Supply connection, power supply 3-phase 380-480 VAC, 50/60 Hz
PE		PE	Ground connection, PE connection
KL 2	1	RSA	Bus connection RS485, RSA, MODBUS-RTU; SELV
KL 2	2	RSB	Bus connection RS485, RSB, MODBUS-RTU; SELV
KL 2	3	GND	Reference ground for control interface; SELV
KL2	4	C	Status relay, floating status contact, break for failure; contact rating 250 VAC / max. 2 A (AC1) / min. 10 mA
KL 2	5	Din1	Digital input 1 enable electronics, enable: pin open or applied voltage 5-50 VDC disable: bridge to GND or applied voltage < 1 VDC reset function: triggers software reset after a level change to < 1 V; SELV
KL 2	6	+ 10 V	Fixed voltage output 10 VDC, +10 V ±3%, max. 10 mA, short-circuit-proof, power supply for external devices (e.g. pot); SELV Or: +24 VDC input for parameter setting via MODBUS without line voltage
KL 2	7	Ain1 U	Analog input 1 (set value) 0-10 V, Ri = 100 kΩ, adjustable curve; SELV
KL2	8	NC	Status relay, floating status contact, break for failure



## Curves: Air performance 50 Hz

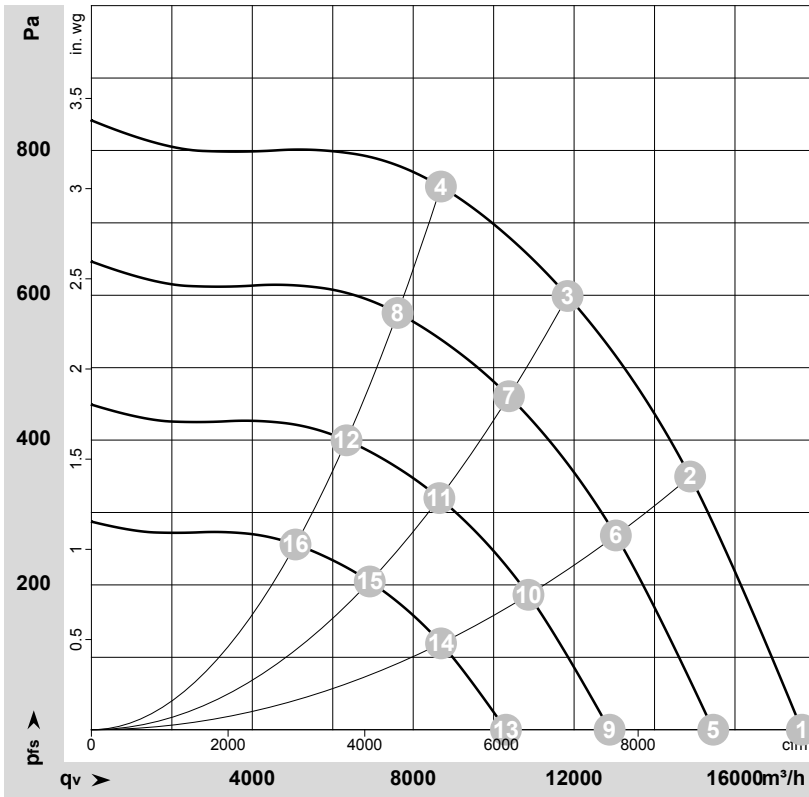

$\rho = 1.15 \text{ kg/m}^3 \pm 2 \%$

Measurement: LU-188195-1

Air performance measured according to ISO 5801 installation category A. For detailed information on the measurement setup, contact ebmpapst. Intake sound level: Sound power level according to ISO 13347 / sound pressure level measured at 1 m distance from fan axis. The values given are valid under the specified measuring conditions and may vary due to conditions of installation. For deviations from the standard configuration, the parameters have to be checked on the installed unit.

## Measured values

	Wired	U	f	n	P <sub>ed</sub>	I	LpA <sub>in</sub>	LwA <sub>in</sub>	LwA <sub>out</sub>	q <sub>v</sub>	p <sub>fs</sub>	q <sub>v</sub>	p <sub>fs</sub>
		V	Hz	min <sup>-1</sup>	W	A	dB(A)	dB(A)	dB(A)	m <sup>3</sup> /h	Pa	cfm	in. wg
1	3~	400	50	1370	2123	3.31	83	90	94	17665	0	10395	0.00
2	3~	400	50	1370	2936	4.51	77	84	88	14885	350	8760	1.41
3	3~	400	50	1370	3250	5.00	71	79	84	11840	600	6970	2.41
4	3~	400	50	1370	3153	4.83	73	81	85	8690	750	5115	3.01
5	3~	400	50	1200	1424	2.22	80	87	91	15460	0	9100	0.00
6	3~	400	50	1200	1973	3.03	73	80	85	13040	268	7675	1.08
7	3~	400	50	1200	2190	3.35	68	75	81	10380	465	6110	1.87
8	3~	400	50	1200	2119	3.25	70	77	82	7610	576	4480	2.31
9	3~	400	50	1000	824	1.28	76	82	86	12885	0	7585	0.00
10	3~	400	50	1000	1142	1.75	69	76	80	10865	186	6395	0.75
11	3~	400	50	1000	1267	1.94	63	71	76	8650	323	5090	1.30
12	3~	400	50	1000	1226	1.88	65	73	77	6340	400	3735	1.61
13	3~	400	50	800	422	0.66	70	77	80	10305	0	6065	0.00
14	3~	400	50	800	585	0.90	63	70	75	8690	119	5115	0.48
15	3~	400	50	800	649	0.99	57	65	71	6920	206	4075	0.83
16	3~	400	50	800	628	0.96	59	67	72	5075	256	2985	1.03

Wired = Wiring · U = Power supply · f = Frequency · n = Speed (rpm) · P<sub>ed</sub> = Power consumption · I = Current draw · LpA<sub>in</sub> = Sound pressure level intake side · LwA<sub>in</sub> = Sound power level intake side  
 LwA<sub>out</sub> = Sound power level outlet side · q<sub>v</sub> = Air flow · p<sub>fs</sub> = Pressure increase

