

ASIA PACIFIC SHENGRUI LIMITED

Phone +00852 56261528

info@apacfan.com

www.apacfan.com



Nominal data

Type	W6D910-HA01-01		
Motor	M6D138-NA		
Phase		3~	3~
Nominal voltage	VAC	400	400
Connection		Δ	Y
Frequency	Hz	50	50
Type of data definition		ml	ml
Valid for approval / standard		CE	CE
Speed	min ⁻¹	885	685
Power input	W	2480	1570
Current draw	A	5.15	2.9
Max. back pressure	Pa	150	90
Min. ambient temperature	°C	-40	-40
Max. ambient temperature	°C	50	50
Starting current	A	18.6	6.2

ml = Max. load · me = Max. efficiency · fa = Running at free air · cs = Customer specs · cu = Customer unit
Subject to alterations

Data according to ErP directive

Installation category	A
Efficiency category	Static
Variable speed drive	No
Specific ratio*	1.00

* Specific ratio = $1 + p_{fs} / 100\,000\text{ Pa}$

		Actual	Request 2013	Request 2015
Overall efficiency η_{es}	%	40	32.2	36.2
Efficiency grade N		43.8	36	40
Power input P_e	kW	2.49		
Air flow q_v	m ³ /h	22810		
Pressure increase p_{fs}	Pa	158		
Speed n	min ⁻¹	895		

Data definition with optimum efficiency. LUJ-153416
The ErP data is determined using a motor-impeller combination in a standardised measurement configuration.



Technical features

Mass	64 kg
Size	910 mm
Surface of rotor	Cast in aluminium
Material of terminal box	PC plastic
Material of blades	Aluminium sheet insert, sprayed with PP plastic
Material of mounting ring	Steel, coated in black plastic (RAL 9005)
Material of wall ring	Sheet steel, pre-galvanised and coated in black plastic (RAL 9005)
Material of guard grille	Steel, coated in black plastic (RAL9005)
Material of outer diffuser	PP plastic
Material of inner diffuser including lid	PP plastic
Number of blades	5
Blade angle	0°
Direction of air flow	"V"
Direction of rotation	Clockwise, seen on rotor
Type of protection	IP 54
Insulation class	"F"
Humidity class	F3-1
Max. permissible ambient motor temp. (transp./ storage)	+80 °C
Min. permissible ambient motor temp. (transp./storage)	-40 °C
Mounting position	Shaft horizontal or rotor on bottom; rotor on top on request
Condensate discharge holes	On rotor and stator sides
Operation mode	S1
Motor bearing	Ball bearing
Touch current acc. IEC 60990 (measuring network Fig. 4, TN system)	<= 3.5 mA
Electrical leads	Via terminal box
Motor protection	Thermal overload protector (TOP) brought out
Cable exit	Lateral
Protection class	I (if protective earth is connected by customer)
Product conforming to standard	EN 60034; EN 61800-5-1; CE
Approval	EAC; VDE

AC axial fan - HyBlade®

sickled blades (S series)

with full square nozzle with AxiTop diffuser

Product drawing

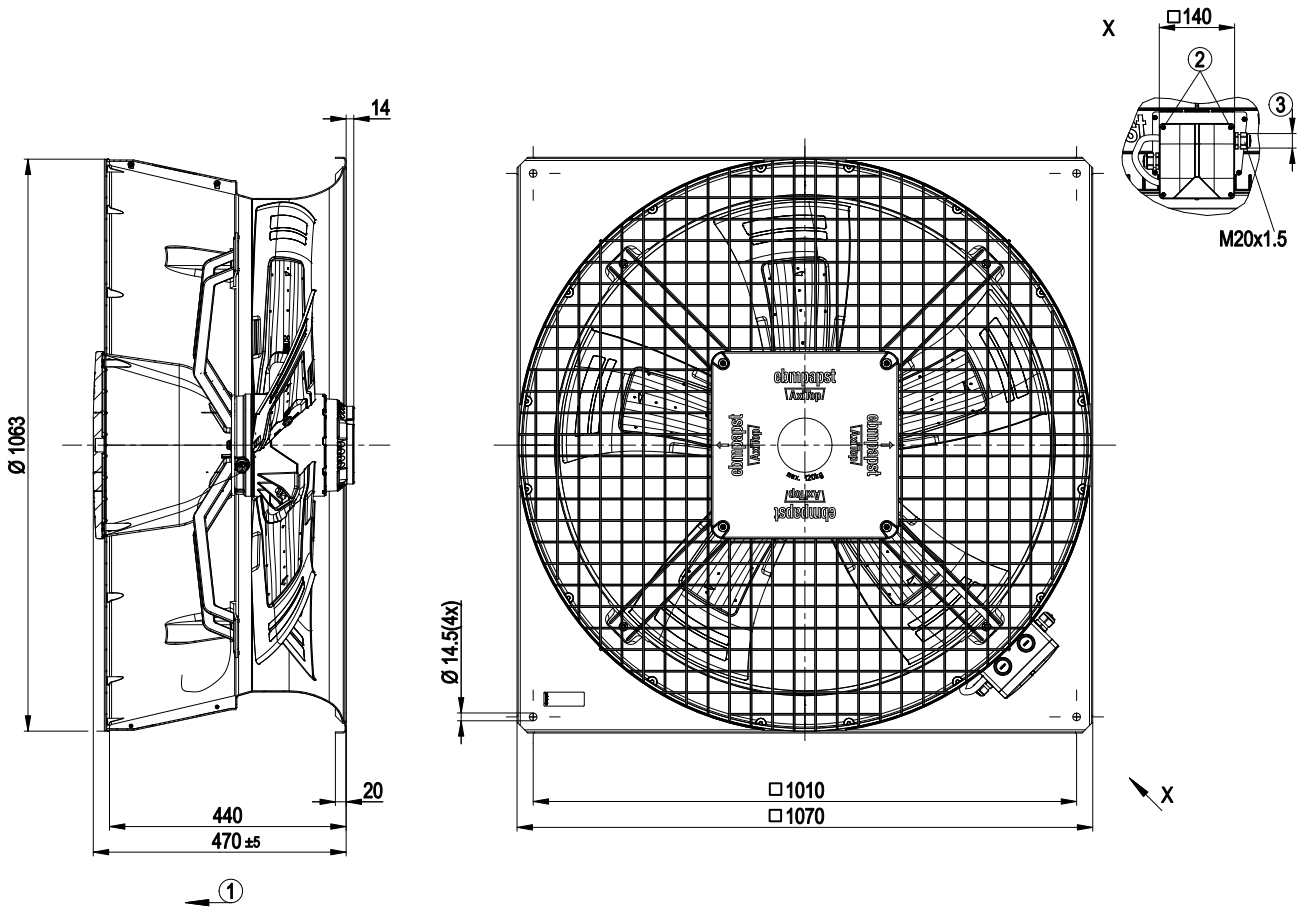

1	Direction of air flow "V"
2	Tightening torque 1.7 ± 0.2 Nm
3	Cable diameter: min. 6 mm, max. 12 mm; tightening torque 4 ± 0.6 Nm



AC axial fan - HyBlade®

sickled blades (S series)

with full square nozzle with AxiTop diffuser

Connection screen

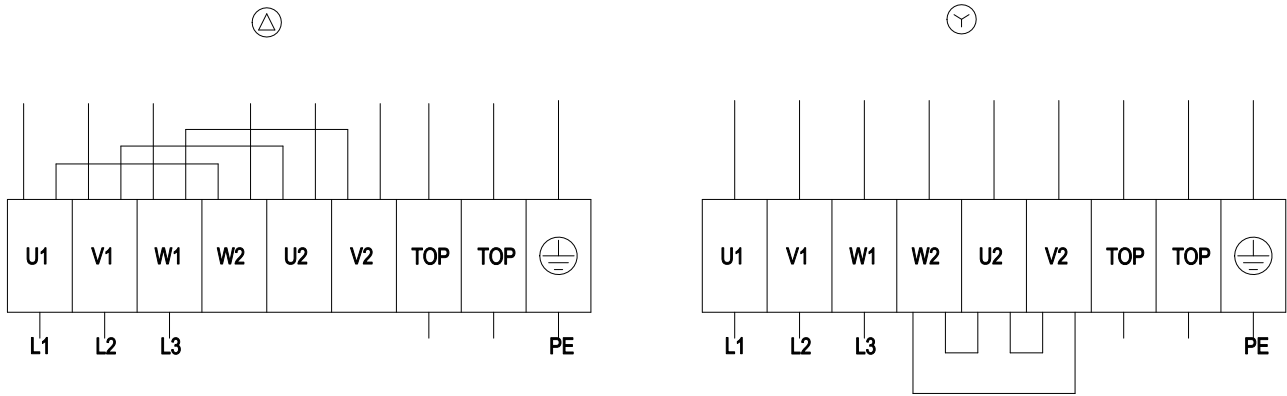

Δ	Delta connection	Y	Star connection	L1	= U1 = black
L2	= V1 = blue	L3	= W1 = brown	W2	yellow
U2	green	V2	white	TOP	2 x grey
PE	green/yellow				

Charts: Air flow 50 Hz

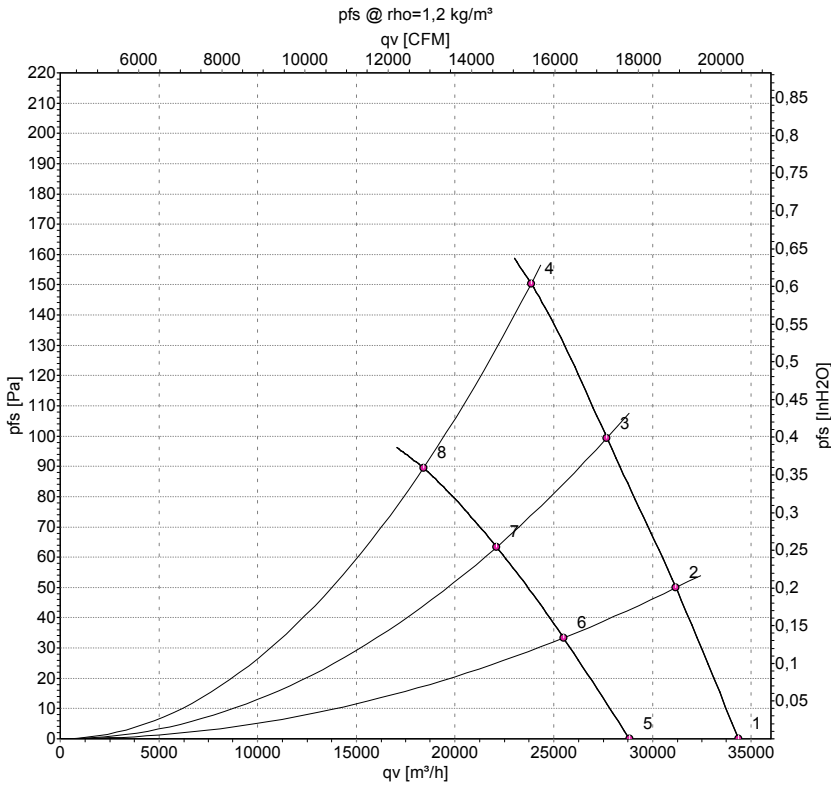

Measurement: LU-153416
Measurement: LU-153415

Air performance measured as per ISO 5801 Installation category A. For detailed information on the measuring set-up, please contact ebm-papst. Suction-side noise levels: LwA measured as per ISO 13347 / LpA measured with 1m distance to fan axis. The values given are valid under the measuring conditions mentioned above and may vary according to the actual installation situation. With any deviation from the standard set-up, the specific values have to be checked and reviewed with the unit installed.

Measured values

	Conn.	U	f	n	P _e	I	LpA _{in}	LwA _{in}	LwA _{out}	qv	p _{fs}
		V	Hz	min ⁻¹	W	A	dB(A)	dB(A)	dB(A)	m ³ /h	Pa
1	Δ	400	50	930	1708	4.08	72	80	81	34345	0
2	Δ	400	50	920	1987	4.43	71	78	79	31185	50
3	Δ	400	50	910	2211	4.69	69	77	77	27690	100
4	Δ	400	50	885	2480	5.15	69	77	77	23850	150
5	Y	400	50	795	1267	2.32	68	75	76	28830	0
6	Y	400	50	755	1411	2.59	65	73	73	25490	34
7	Y	400	50	720	1526	2.81	63	71	71	22105	64
8	Y	400	50	685	1570	2.90	63	71	72	18395	89

Conn. = Connection · U = Supply voltage · f = Frequency · n = Speed · P_e = Power input · I = Current draw · LpA_{in} = Sound pressure level inlet side · LwA_{in} = Sound power level inlet side
LwA_{out} = Sound power level outlet side · qv = Air flow · p_{fs} = Pressure increase

