

**KRUGER**

# AXIAL FLOW FAN **TDA SERIES**

T  
D  
A  
  
S  
e  
r  
i  
e  
s



**SIMPLE YET  
STURDY**



**EASY  
INSTALLATION**



**LOW  
MAINTENANCE**

## Why KRUGER ?

KRUGER has been a leading innovator and manufacturer of residential, commercial and industrial fan application solutions across Asia since 1985. Today with a direct presence in over 18 regions throughout Asia; world class R&D and manufacturing facilities; KRUGER are able to offer their customers unparalleled service and support at a local level. Our customers place their trust in KRUGER.



## What is a KRUGER TDA Axial Flow Fan ?

The TDA series is an economical axial fan designed for general clean air and smoke spill applications. It offers a good amount of airflow at medium pressure levels, and its simple, yet durable construction makes installation easy and maintenance minimal.

## Why use a KRUGER TDA Axial Flow Fan ?



### Simplified Design -> Reliable -> Low Startup Cost

The simple design of TDA fans contributes to their reliability. TDA has fewer complex components that might malfunction, providing cost-effective solutions and resulting to longer service life.

### Direct-Driven -> Ease of Maintenance -> Reduced Maintenance Costs

The impeller of the TDA fan is directly attached to the motor shaft, eliminating losses due to drive transmission. This design not only simplifies maintenance but also facilitates part replacement.

### Versatile Design -> Easy to Install -> Suitable for Various Ventilation Applications

Suitable for the extract (or supply) of clean, or high temperature airstreams. The manually adjustable pitch angle impeller of TDA fans provides a wide selection and application range, and is easy to adjust during fan commissioning.



Horizontal Floor Mount



Vertical Floor Mount



Horizontal Ceiling Hung



Vertical Ceiling Hung

### Third Party Certification -> Guaranteed Performance -> What you see is what you get!

TDA fans undergo rigorous testing and receive certification from reputable third-party organizations, including AMCA and APPLUS. These tests adhere to national and international standards and are carried out in accredited testing facilities.

## Air Performance and High Temperature Certification



◀ The quality and reliability of our products and services are recognized by certification bodies and accreditation authorities worldwide.

The TDA series is backed by Third-Party Certification, ensuring life safety through verified air flow performance, smoke, and fire protection.



◀ Kruger Ventilation Industries Asia Co., Ltd certifies that the TDA Series shown herein is licensed to bear the AMCA Seal. The ratings shown are based on tests and procedures performed in accordance with AMCA publication 211 and AMCA publication 311 and comply with the requirements of the AMCA Certified Ratings Program.

Certified for high-temperature performance (up to 400°C/2Hrs) in accordance with EN12101-3 Standard, by globally renowned third-party testing and certification organizations, APPLUS, and TÜV SÜD.



Class	Temperature (°C)	Minimum functioning period (Minutes)
F <sub>250</sub>	250	120
F 300	300	60
F <sub>300</sub>	300	120
F 400	400	120

◀ \*Please contact nearest KRUGER office for TDA F400 application range.



◀ TDA315 Fan Testing at APPLUS Test Laboratory in Spain.

T  
D  
A  
  
S  
e  
r  
i  
e  
s

## Application



◀ Commercial Building



◀ Shopping center



◀ Transport



◀ Carpark

## Summary of key standard TDA Series specifications:

- A- Airflow and static** pressure performance range up to 127,000 CMH and 1,100 Pa.
- B- Airstream operating temperatures**  
Clean air standard ventilation application -20°C to +55°C.  
High temperature smokespill application up to 300°C/2Hrs
- C- Tube Casing**  
All TDA Series fan casings and components are fabricated from galvanized steel (sizes 315-1120) or high-grade carbon steel (sizes 1250-2000). For even more cost-competitive option, "short-casing" version is available upon request.
- D- Impeller**  
Impeller with manually adjustable pitch angle, Impeller blades are made of Aluminum Alloy.
- E- Coatings**  
All casings and components constructed from high-grade carbon steel will be finished with a zinc primer and a durable polyester coating. The polyester coating finish is salt-spray rated for up to 1000 hours, in accordance with the ASTM B117 testing standard. This makes them suitable for use in both indoor and outdoor environments.
- F- Trim Balancing**  
All TDA Series fans undergo 100% trim balancing in every Kruger factory, achieving up to G2.5 balancing grade, compliant with the AMCA 204 Standard, before they are delivered.
- G- High Efficiency Kruger Motor**  
All TDA Series fans are available with a wide range of both 1PH and 3PH (up to IE4) AC motors, including High-Temperature rated and permanent magnet motor options. For more information, please contact your local KRUGER Distributor.



Trim Balancing

## Options and Accessories

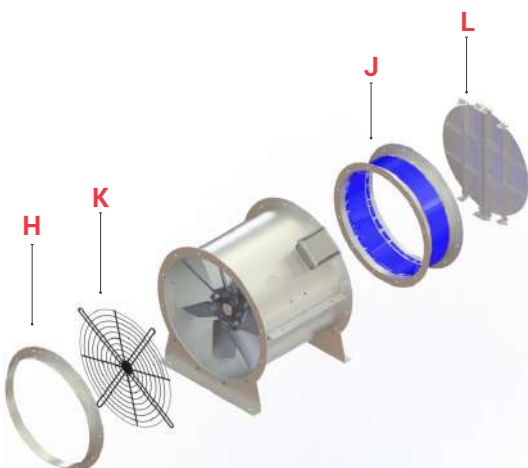

- H-** Inlet and outlet duct connection flanges to connect circular duct to TDA flanges
- J-** Circular flexible duct connectors, both standard and high temperature variations (up to F400).
- K-** Inlet and outlet safety guards.
- L-** Backdraft damper
- M-** Vibration isolator mounts for floor or ceiling mounted installations.
- N-** Special coatings for specialist corrosion application protection.
- P-** Spark resistance construction, per AMCA Standard 99.

## Model number nomenclature

TDA 630 / 12AA / 7-7 / 12 ° / AL / F (400C° / 2hrs)

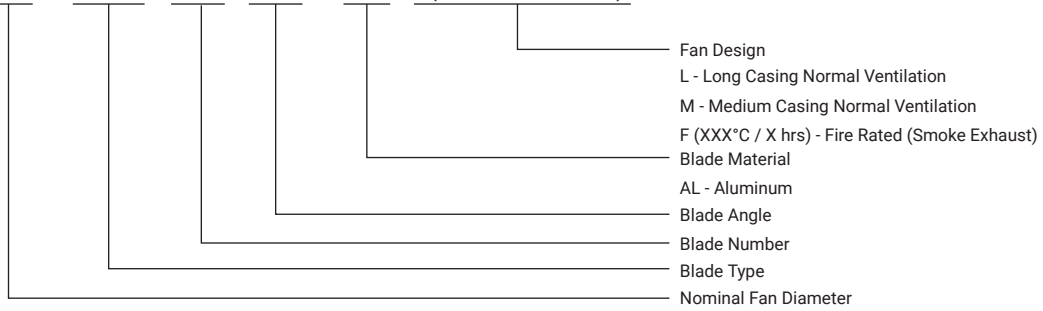

## Dimensions

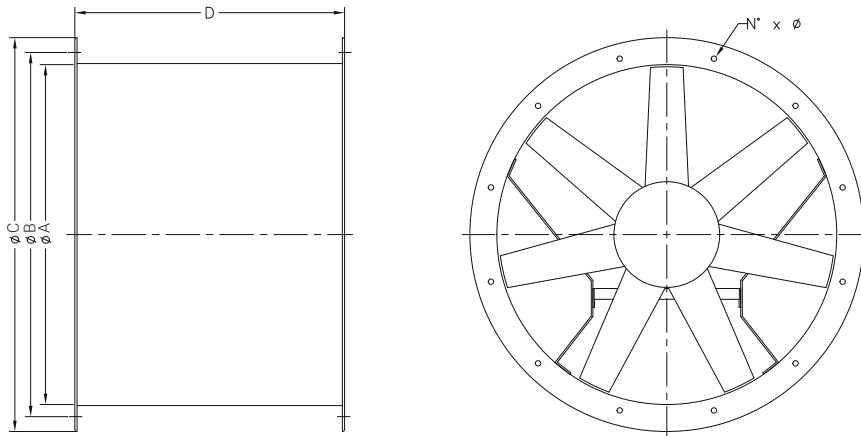

### Dimension

Model	A	B	C	D		N	Ø	Weight (kg)		Max. Motor Frame size
				L/F	M			L/F	M	
355	355	395	435	355	200	8	10	15	12	D80
400	400	440	480	235	355	12	10	17	15	D90L
450	450	490	530	400	255	12	10	21	18	D100L
500	500	540	580	500	285	12	10	26	20	D100L
560	560	605	660	500	346	12	10	31	27	D100L
630	630	675	730	500	346	12	10	38	35	D112M
710	710	755	810	500	406	18	12	57	52	D112M
800	800	845	900	560	406	18	12	68	59	D132M
900	900	945	1000	630	495	18	12	88	79	D160M
1000	1000	1050	1100	630	550	24	12	97	90	D160M
1120	1120	1185	1250	900	650	24	12	149	128	D225M

All dimension in mm.

# TDA355 / 12AA / 7-7 (186)

2850 rpm - 50 Hz

KRUGER

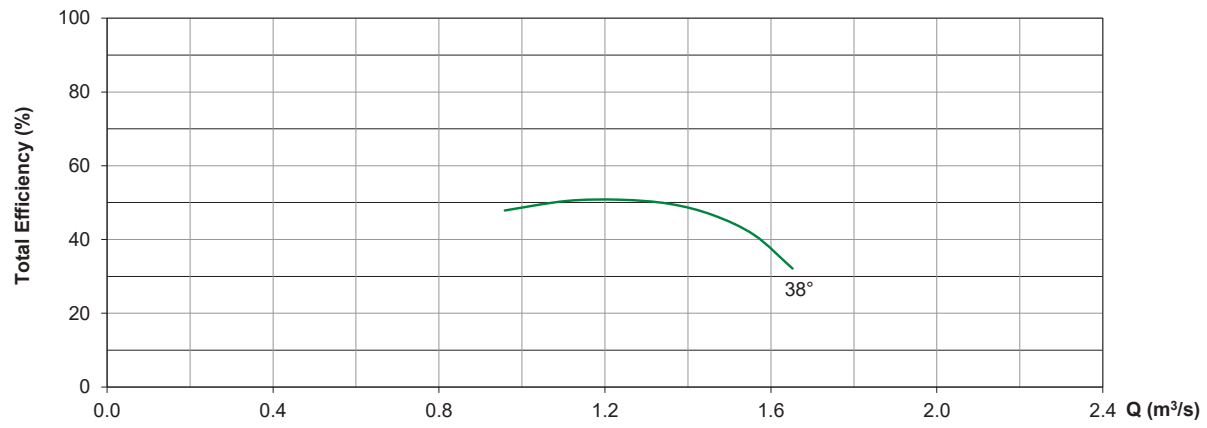
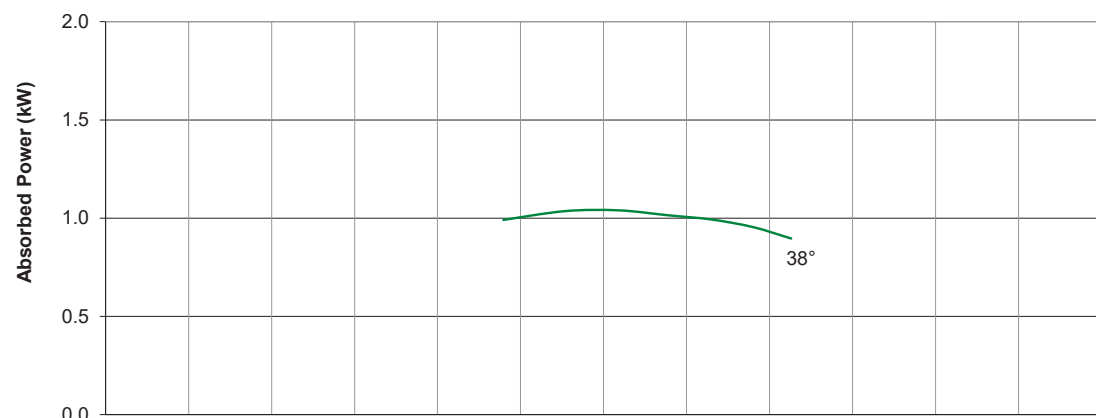
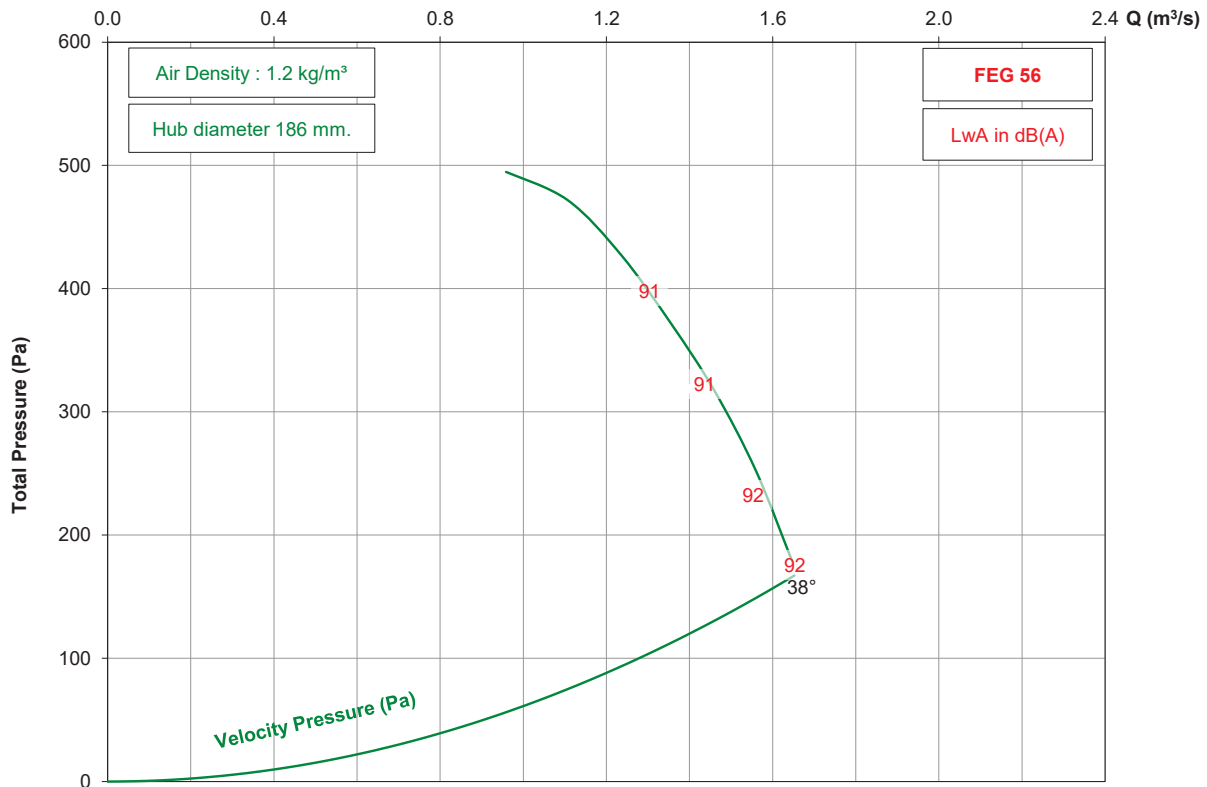

0 5 10 15 20 Vout (m/s)

- Performance certified is for installation type D - ducted inlet, ducted outlet. Performance ratings do not include the effects of appurtenances (accessories).  
 - The A-weighted sound ratings shown have been calculated per AMCA International Standard 301. Values shown are for inlet Lw(A) sound power levels for installation type D - ducted inlet, ducted outlet. Ratings include the effects of duct end correction.

T  
D  
A  
  
S  
e  
r  
i  
e  
s

# TDA355 / 12AA / 7-7 (186)

1450 rpm - 50 Hz

KRUGER

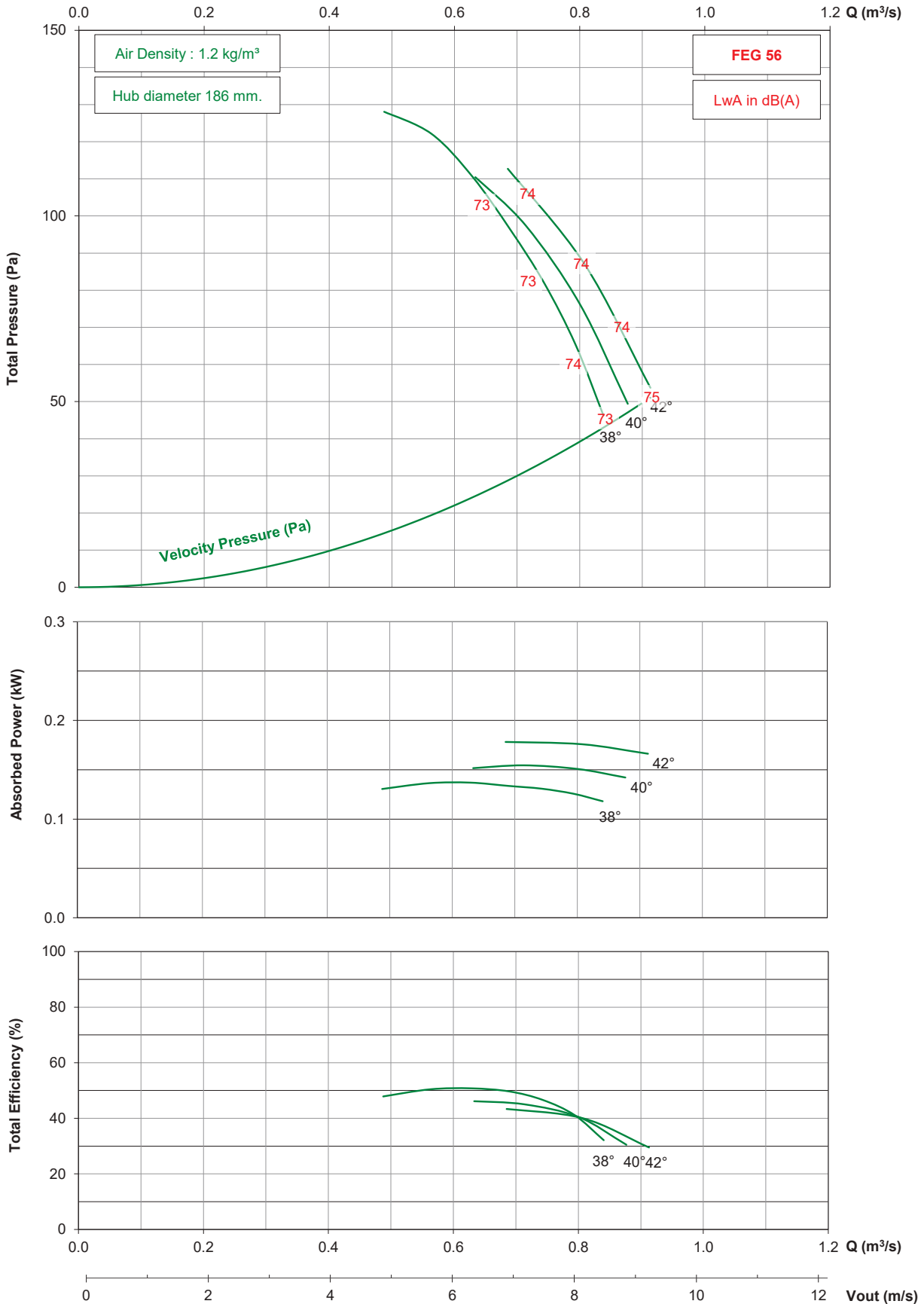

- Performance certified is for installation type D - ducted inlet, ducted outlet. Performance ratings do not include the effects of appurtenances (accessories).  
 - The A-weighted sound ratings shown have been calculated per AMCA International Standard 301. Values shown are for inlet Lwi(A) sound power levels for installation type D - ducted inlet, ducted outlet. Ratings include the effects of duct end correction.

# TDA355 / 12AA / 7-7 (186)

1750 rpm - 60 Hz

KRUGER

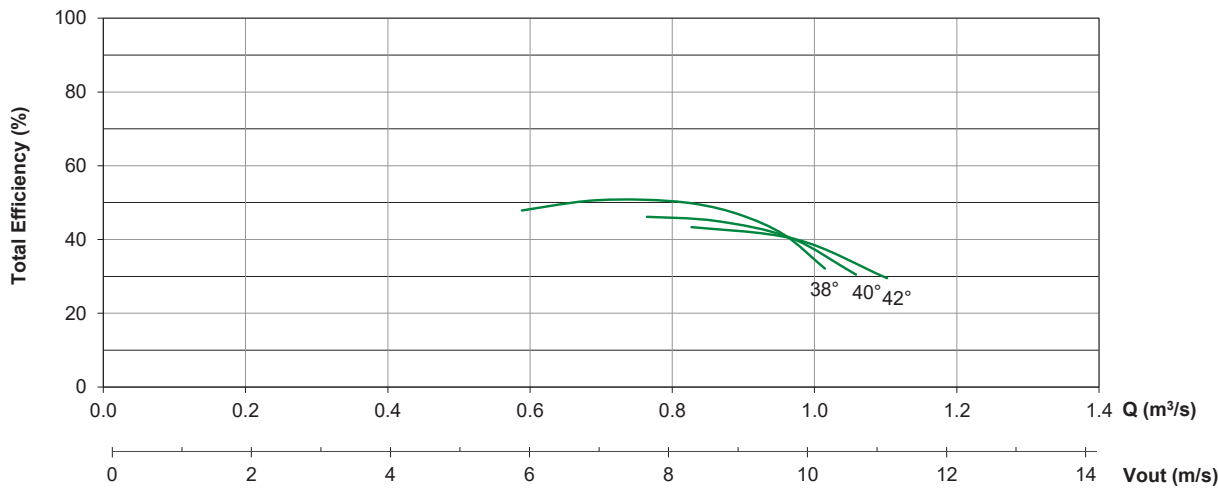
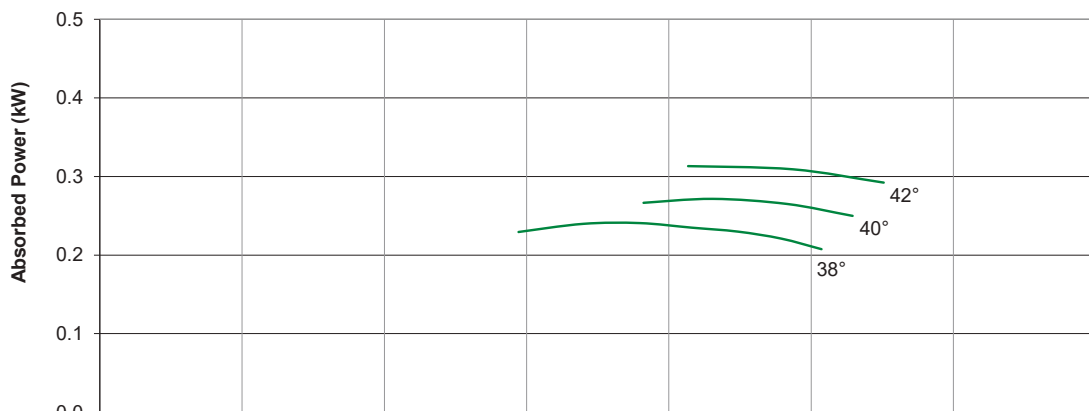
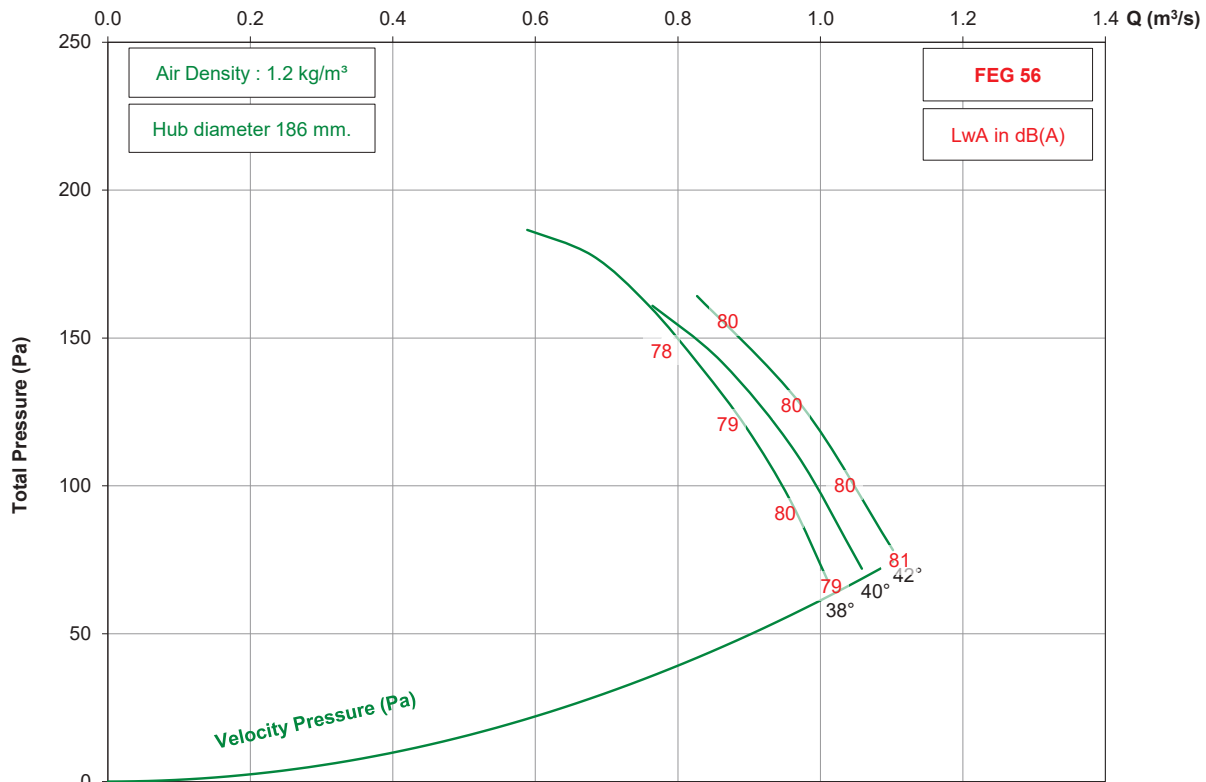

- Performance certified is for installation type D - ducted inlet, ducted outlet. Performance ratings do not include the effects of appurtenances (accessories).  
 - The A-weighted sound ratings shown have been calculated per AMCA International Standard 301. Values shown are for inlet Lwi(A) sound power levels for installation type D - ducted inlet, ducted outlet. Ratings include the effects of duct end correction.

T  
D  
A  
  
S  
e  
r  
i  
e  
s

# TDA400 / 12AA / 9-9 (200)

2850 rpm - 50 Hz

KRUGER

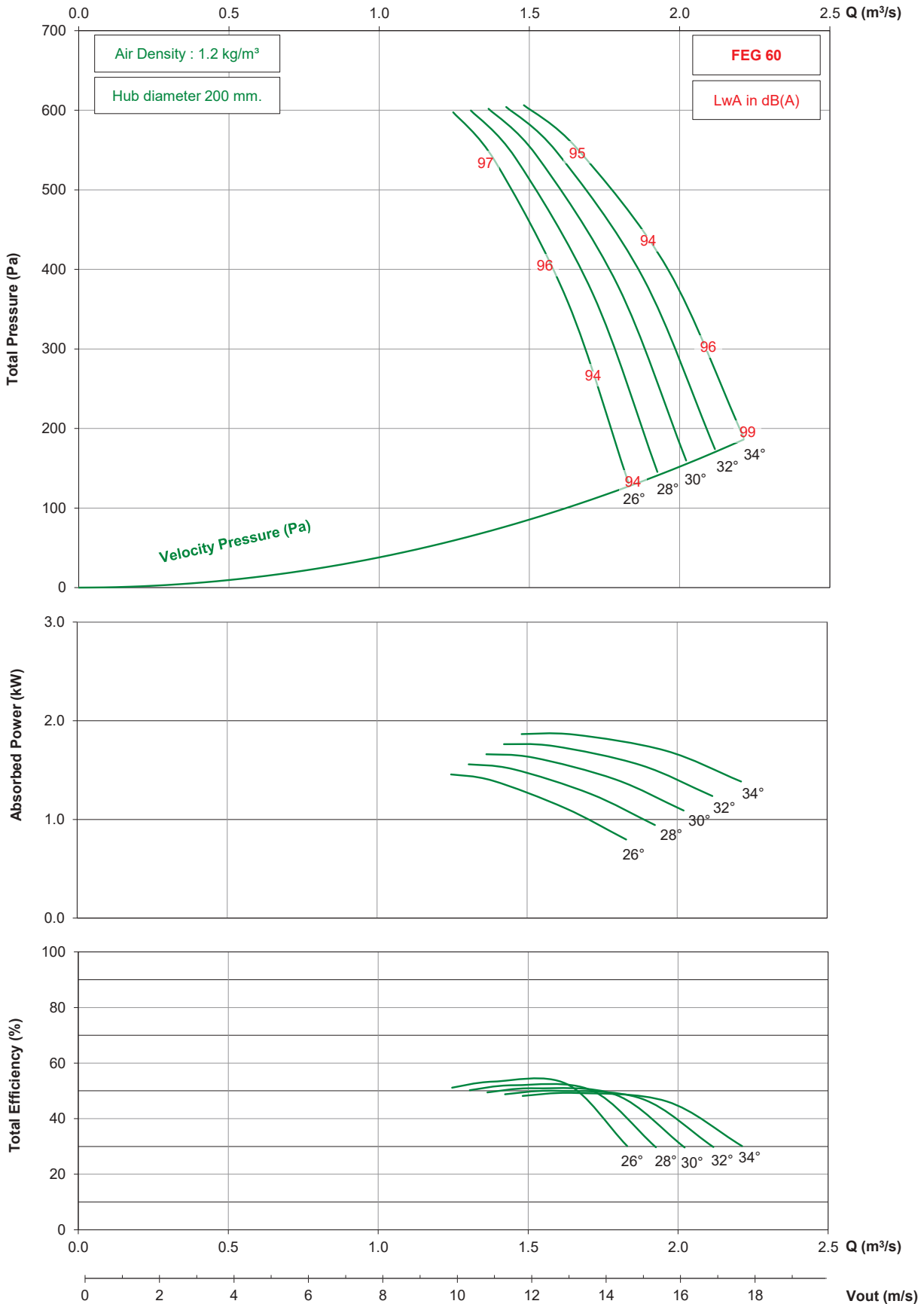

- Performance certified is for installation type D - ducted inlet, ducted outlet. Performance ratings do not include the effects of appurtenances (accessories).  
- The A-weighted sound ratings shown have been calculated per AMCA International Standard 301. Values shown are for inlet Lwi(A) sound power levels for installation type D - ducted inlet, ducted outlet. Ratings include the effects of duct end correction.

TDA Series

# TDA400 / 12AA / 9-9 (200)

1450 rpm - 50 Hz

KRUGER

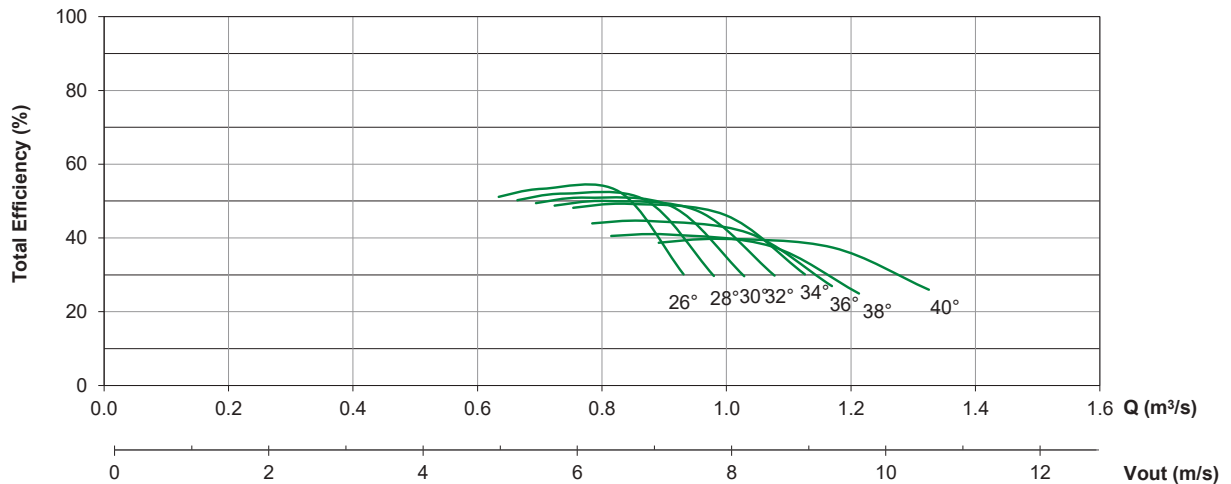
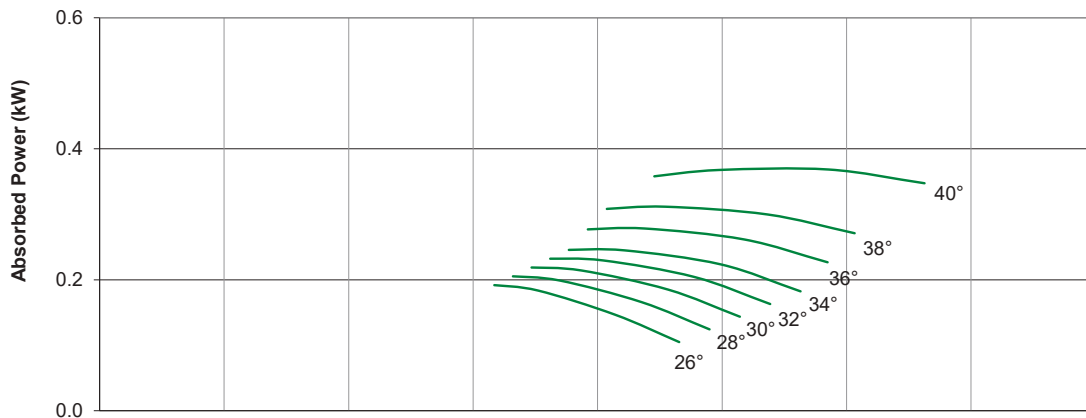
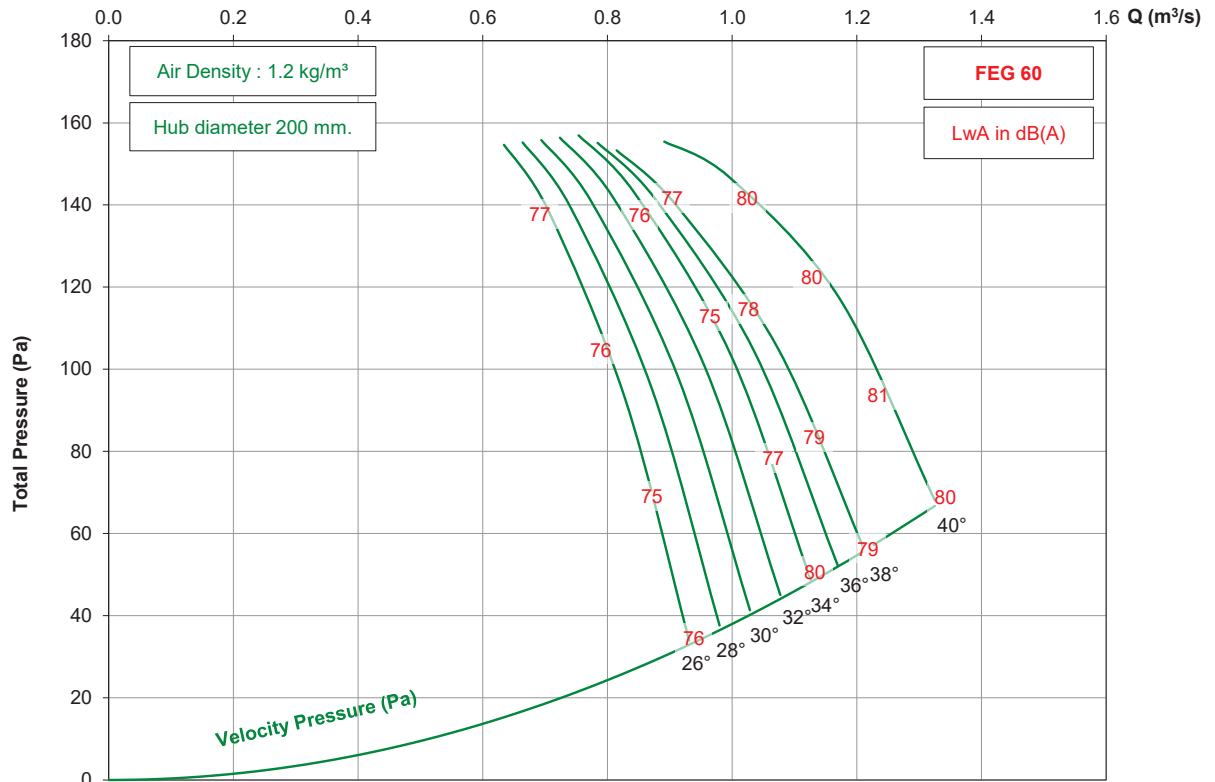

- Performance certified is for installation type D - ducted inlet, ducted outlet. Performance ratings do not include the effects of appurtenances (accessories).  
 - The A-weighted sound ratings shown have been calculated per AMCA International Standard 301. Values shown are for inlet Lwi(A) sound power levels for installation type D - ducted inlet, ducted outlet. Ratings include the effects of duct end correction.

# TDA400 / 12AA / 9-9 (200)

1750 rpm - 60 Hz

KRUGER

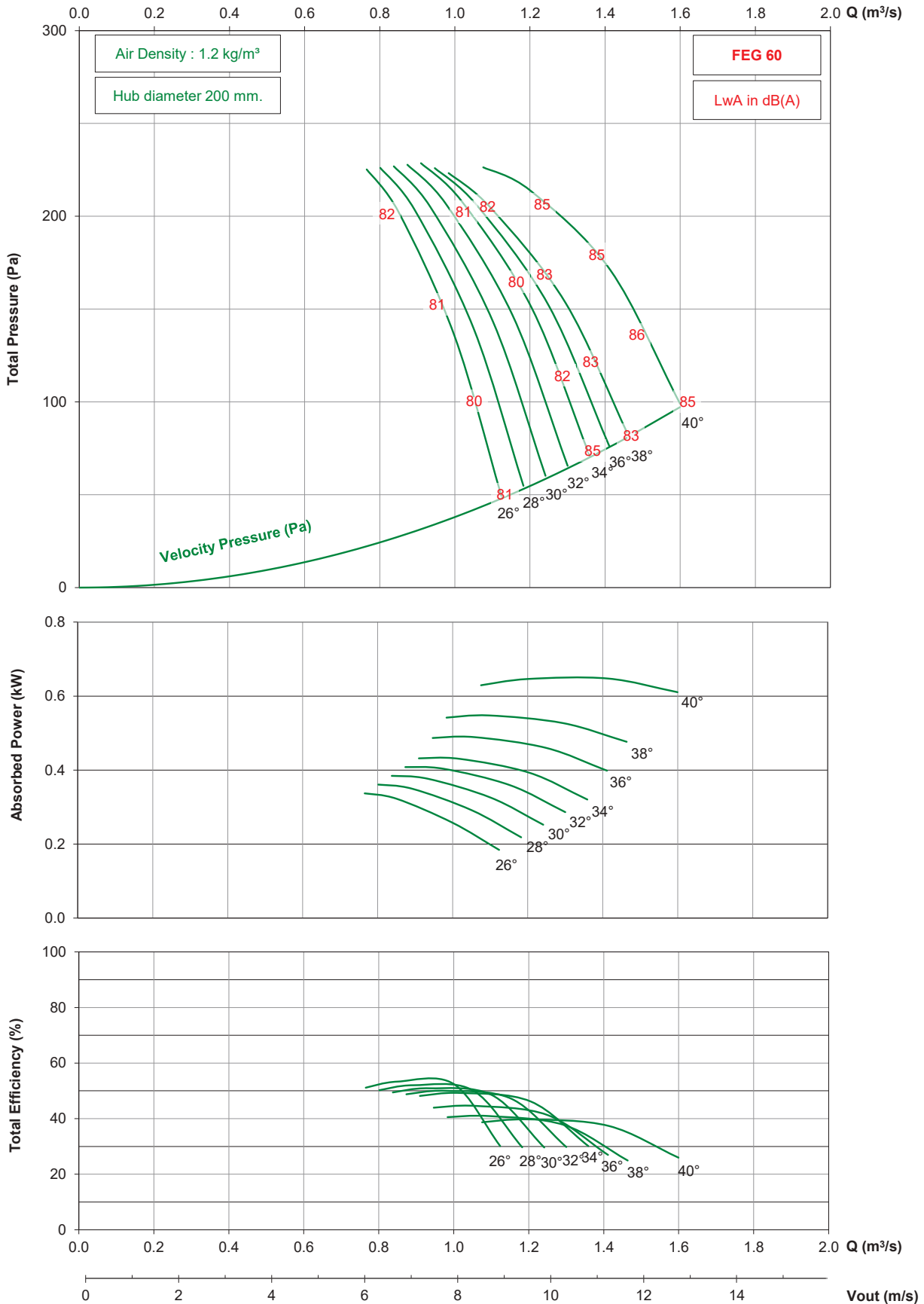

- Performance certified for installation type D - ducted inlet, ducted outlet. Performance ratings do not include the effects of appurtenances (accessories).  
 - The A-weighted sound ratings shown have been calculated per AMCA International Standard 301. Values shown are for inlet Lw(A) sound power levels for installation type D - ducted inlet, ducted outlet. Ratings include the effects of duct end correction.

T  
D  
A  
  
S  
e  
r  
i  
e  
s

# TDA450 / 12AA / 9-9 (200)

2850 rpm - 50 Hz

KRUGER

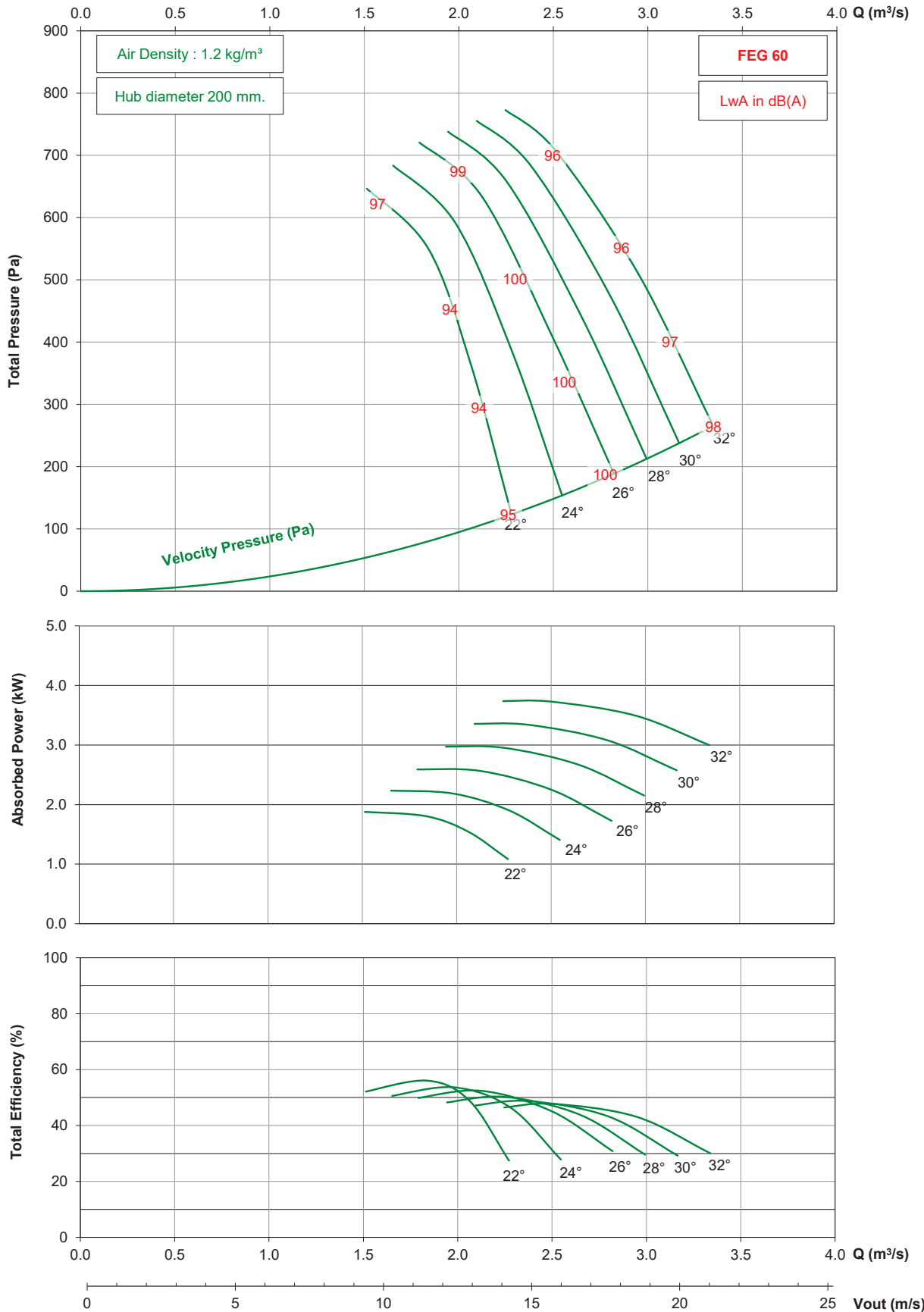

- Performance certified is for installation type D - ducted inlet, ducted outlet. Performance ratings do not include the effects of appurtenances (accessories).  
 - The A-weighted sound ratings shown have been calculated per AMCA International Standard 301. Values shown are for inlet Lw(A) sound power levels for installation type D - ducted inlet, ducted outlet. Ratings include the effects of duct end correction.

T  
D  
A  
  
S  
e  
r  
i  
e  
s

# TDA450 / 12AA / 9-9 (200)

1450 rpm - 50 Hz

KRUGER

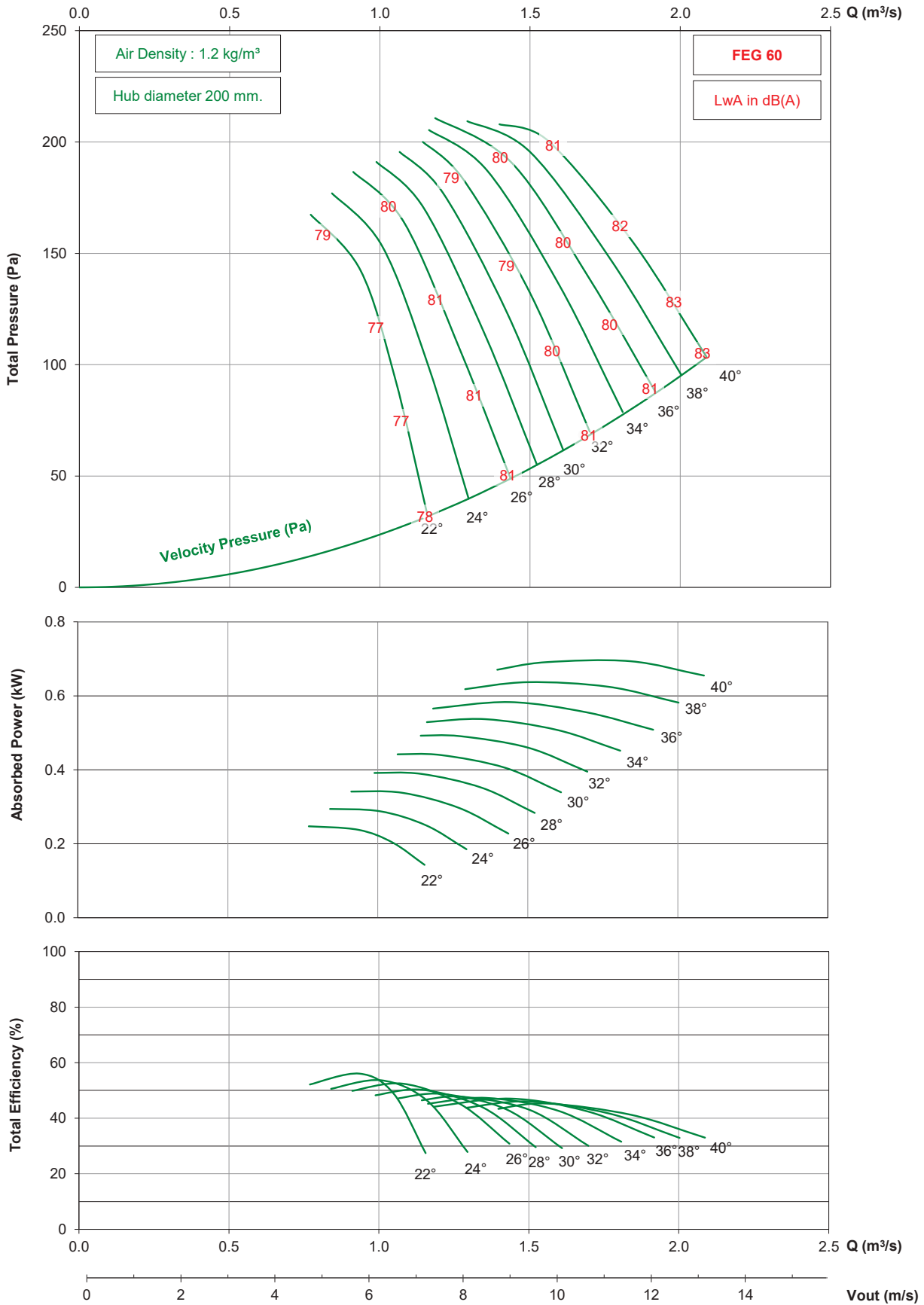

- Performance certified is for installation type D - ducted inlet, ducted outlet. Performance ratings do not include the effects of appurtenances (accessories).

- The A-weighted sound ratings shown have been calculated per AMCA International Standard 301. Values shown are for inlet Lw(A) sound power levels for installation type D - ducted inlet, ducted outlet. Ratings include the effects of duct end correction.

# TDA450 / 12AA / 9-9 (200)

1750 rpm - 60 Hz

KRUGER

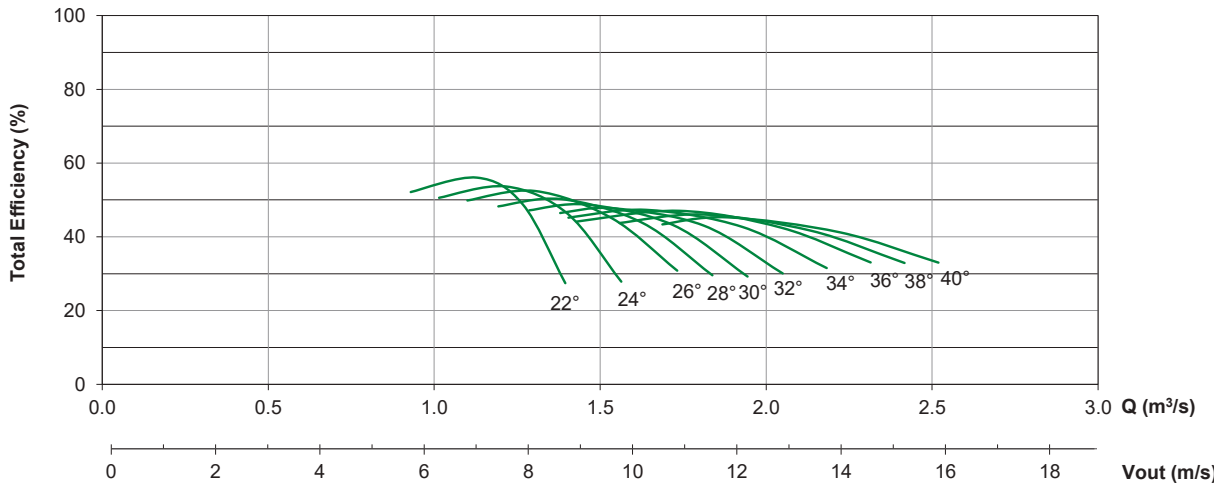
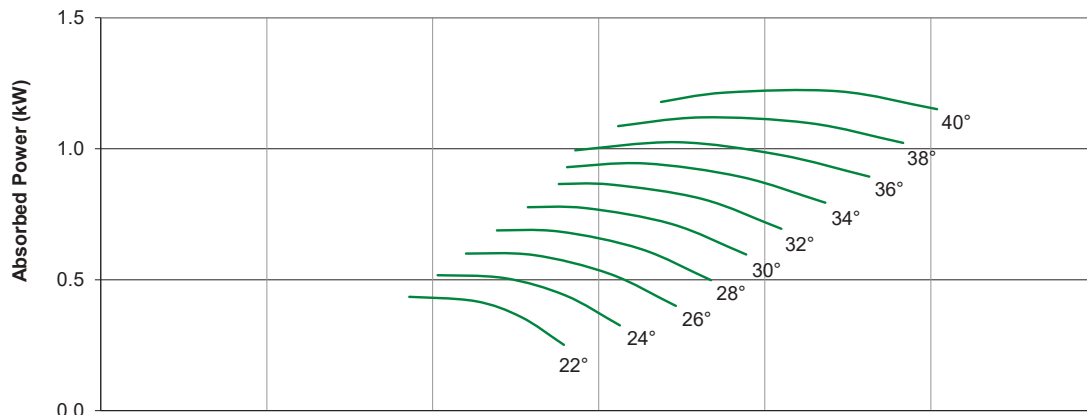
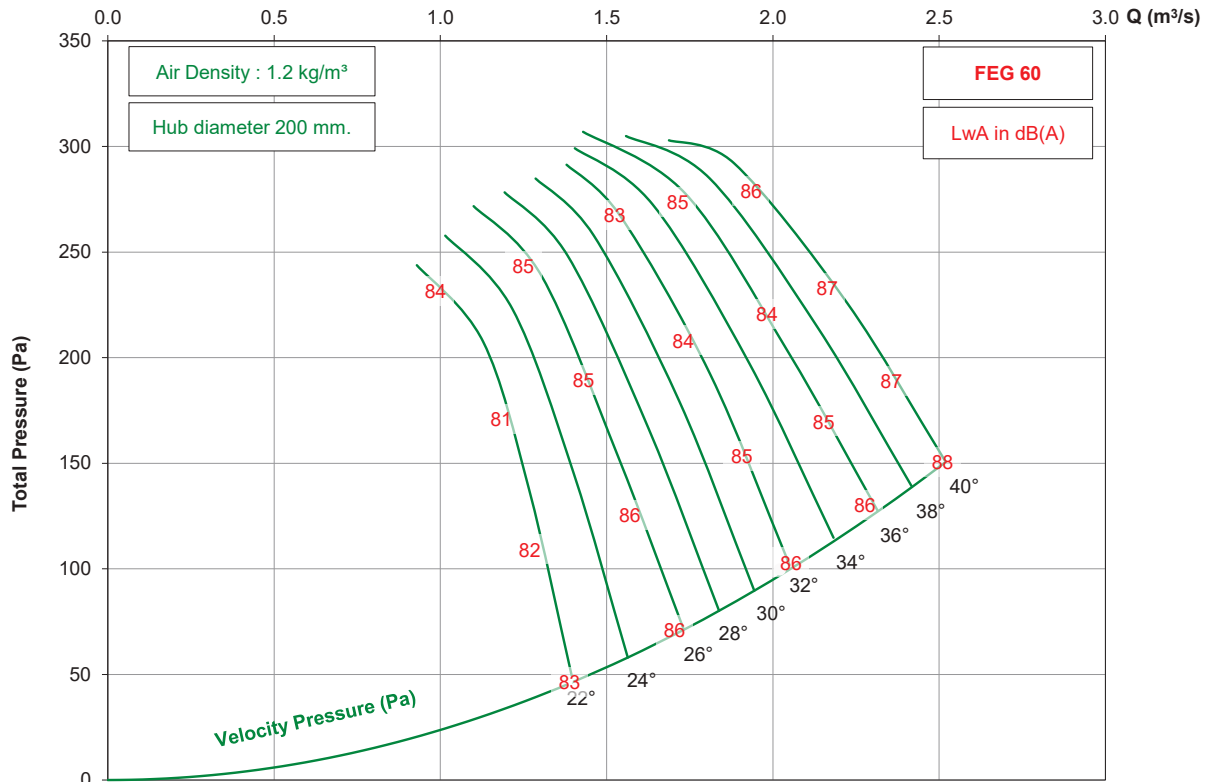

- Performance certified is for installation type D - ducted inlet, ducted outlet. Performance ratings do not include the effects of appurtenances (accessories).  
 - The A-weighted sound ratings shown have been calculated per AMCA International Standard 301. Values shown are for inlet Lw(A) sound power levels for installation type D - ducted inlet, ducted outlet. Ratings include the effects of duct end correction.

TDA Series

# TDA500 / 9AA / 7-7 (186)

2850 rpm - 50 Hz

KRUGER

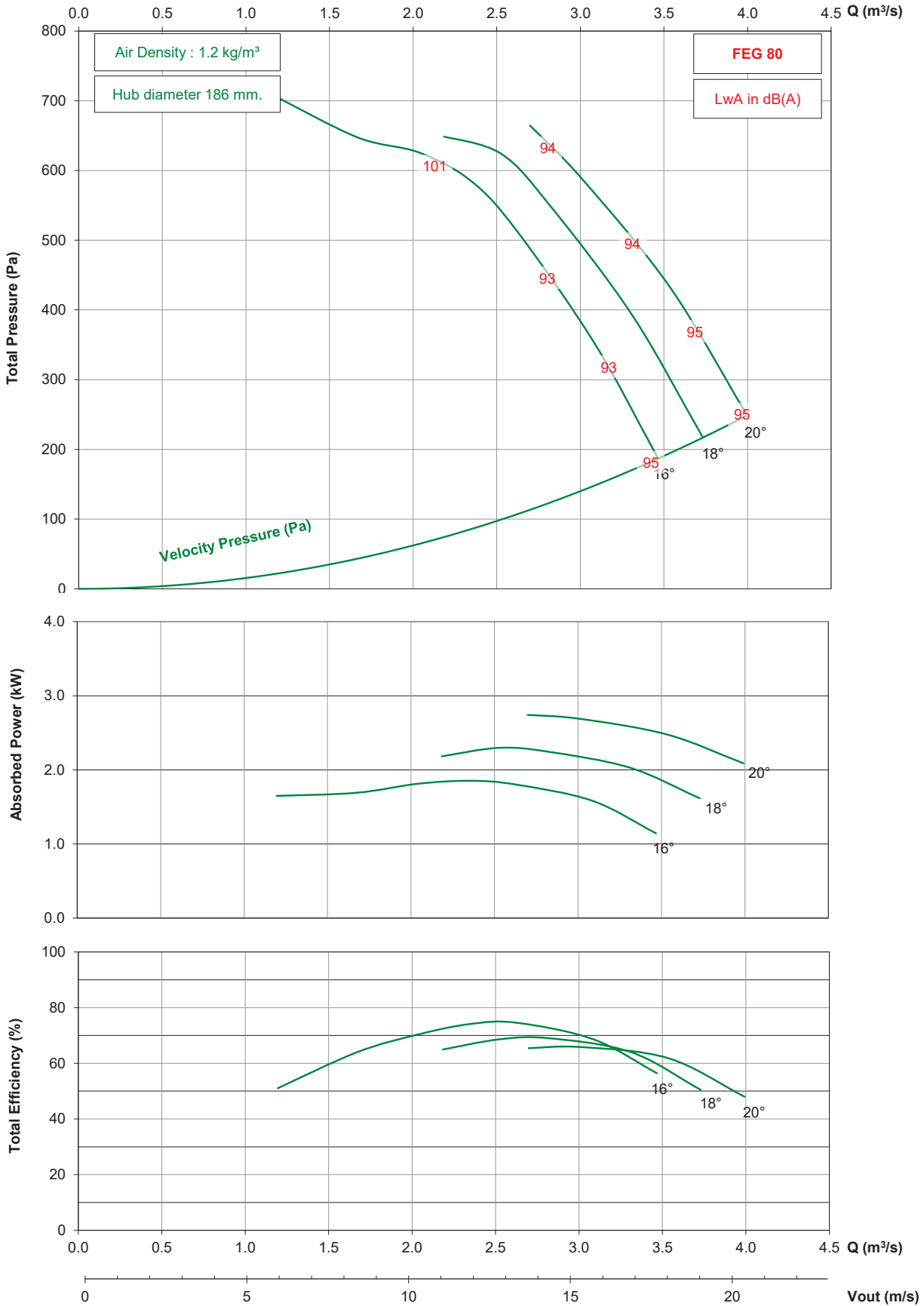

- Performance certified is for installation type D - ducted inlet, ducted outlet. Performance ratings do not include the effects of appurtenances (accessories).

- The A-weighted sound ratings shown have been calculated per AMCA International Standard 301. Values shown are for inlet Lwi(A) sound power levels for installation type D - ducted inlet, ducted outlet. Ratings include the effects of duct end correction.

TDA Series

# TDA500 / 9AA / 7-7 (186)

1450 rpm - 50 Hz

KRUGER

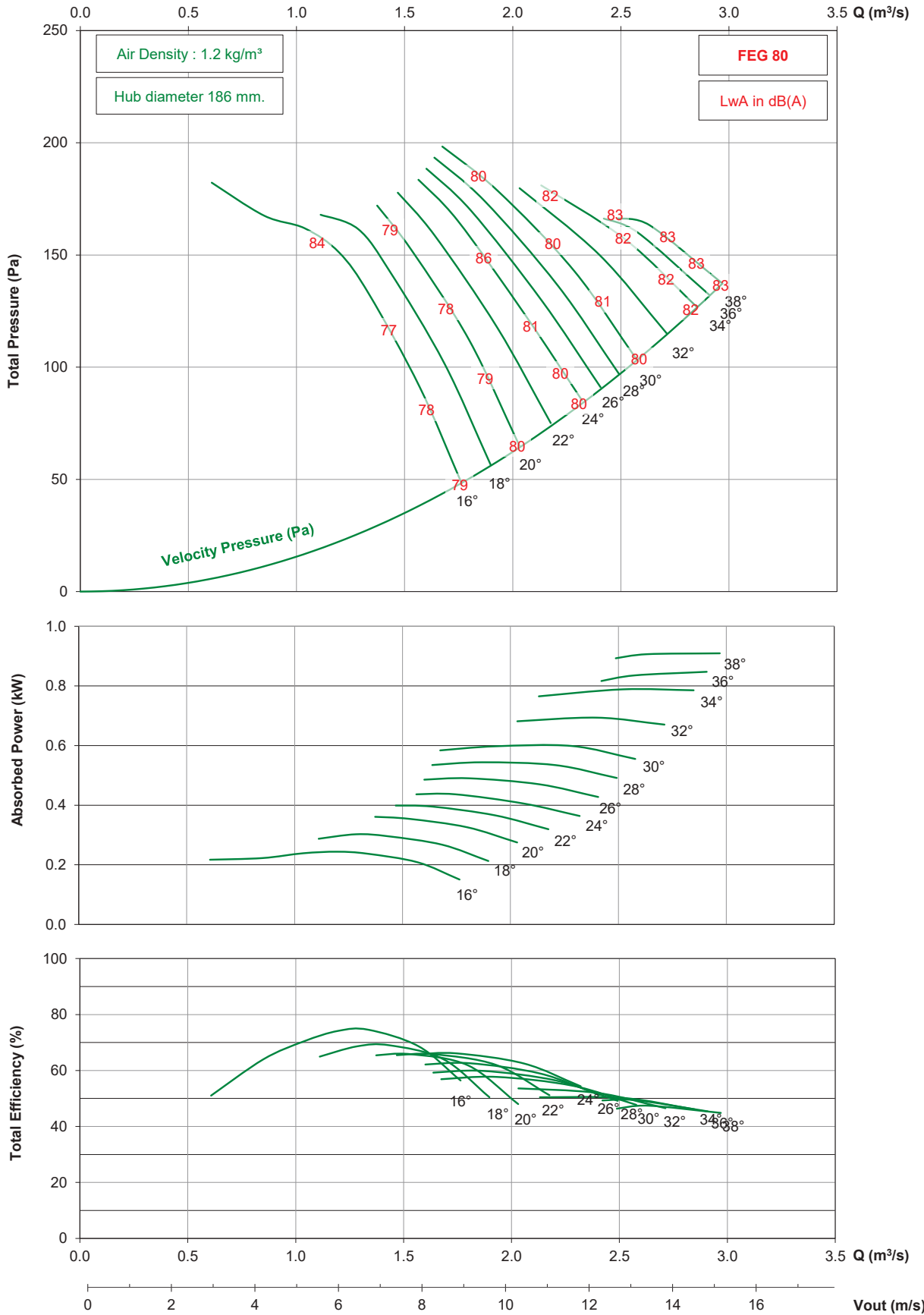

- Performance certified for installation type D - ducted inlet, ducted outlet. Performance ratings do not include the effects of appurtenances (accessories).

- The A-weighted sound ratings shown have been calculated per AMCA International Standard 301. Values shown are for inlet Lwi(A) sound power levels for installation type D - ducted inlet, ducted outlet. Ratings include the effects of duct end correction.

# TDA500 / 9AA / 7-7 (186)

1750 rpm - 60 Hz

KRUGER

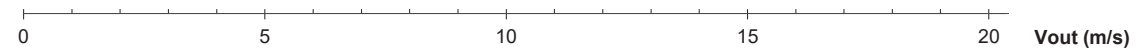
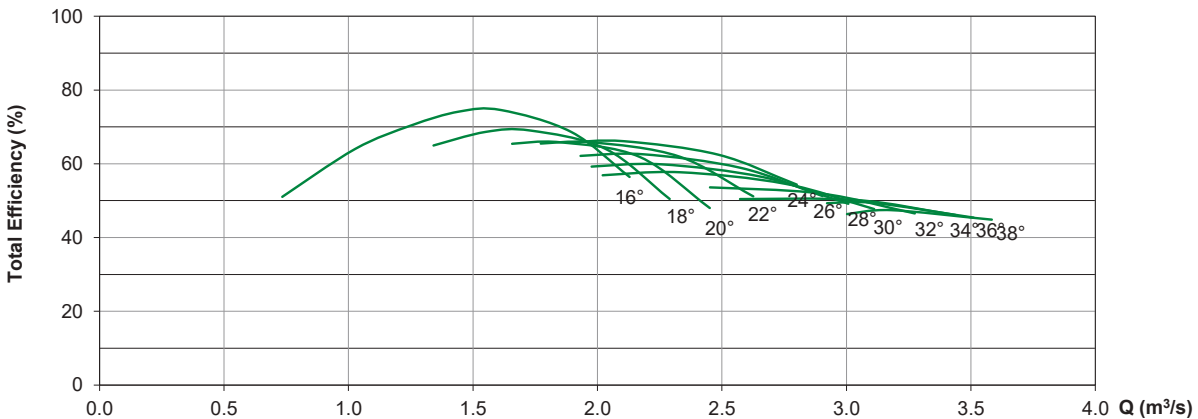
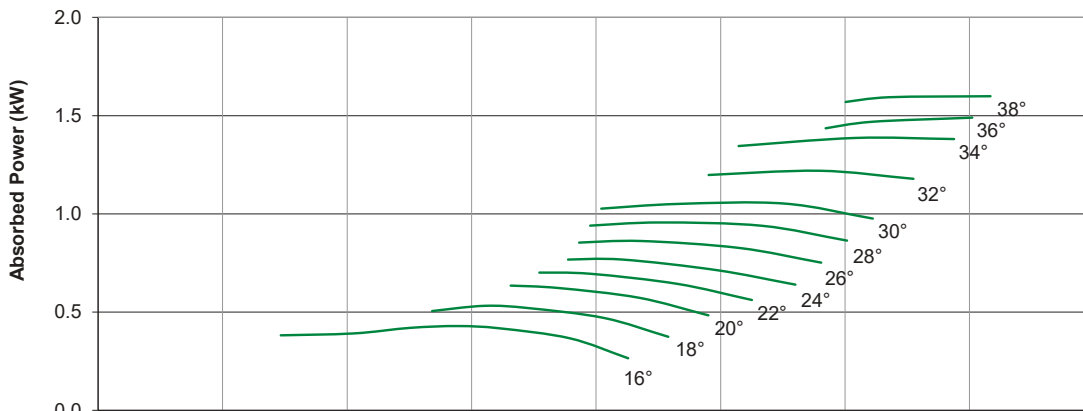
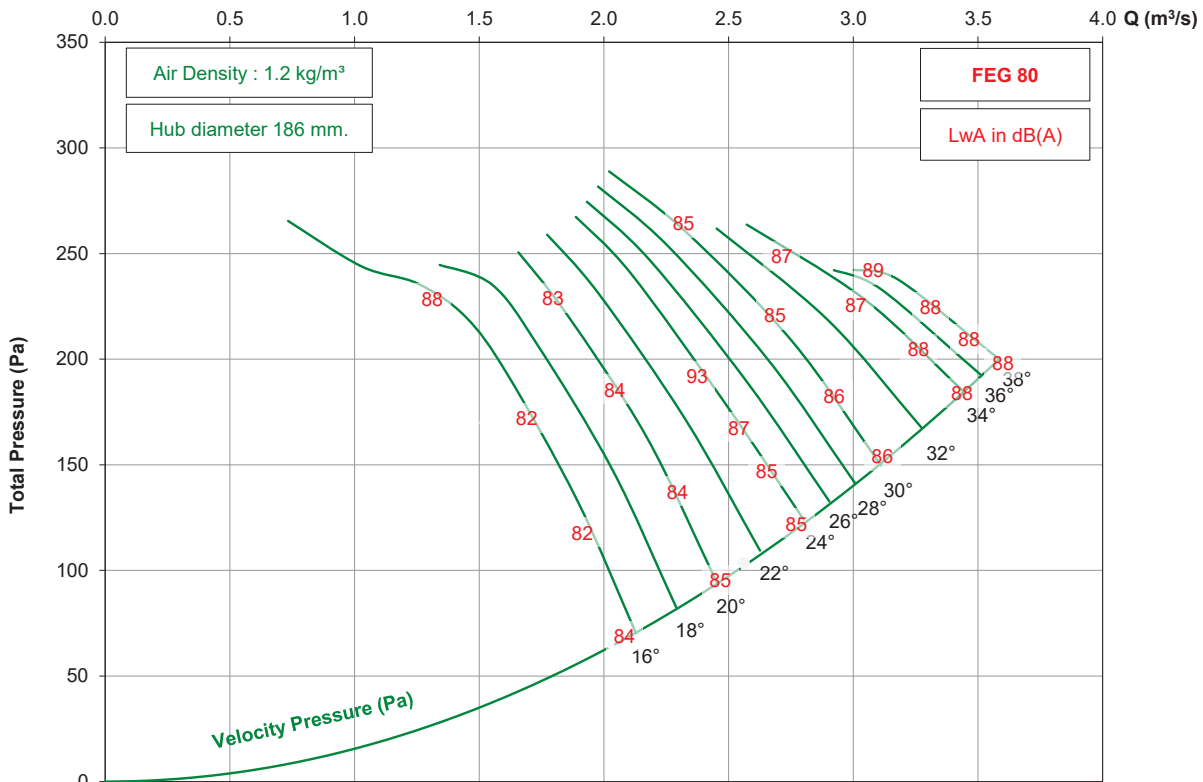

- Performance certified for installation type D - ducted inlet, ducted outlet. Performance ratings do not include the effects of appurtenances (accessories).  
 - The A-weighted sound ratings shown have been calculated per AMCA International Standard 301. Values shown are for inlet Lwi(A) sound power levels for installation type D - ducted inlet, ducted outlet. Ratings include the effects of duct end correction.

TDA Series

# TDA560 / 9AA / 7-7 (186)

2850 rpm - 50 Hz

KRUGER

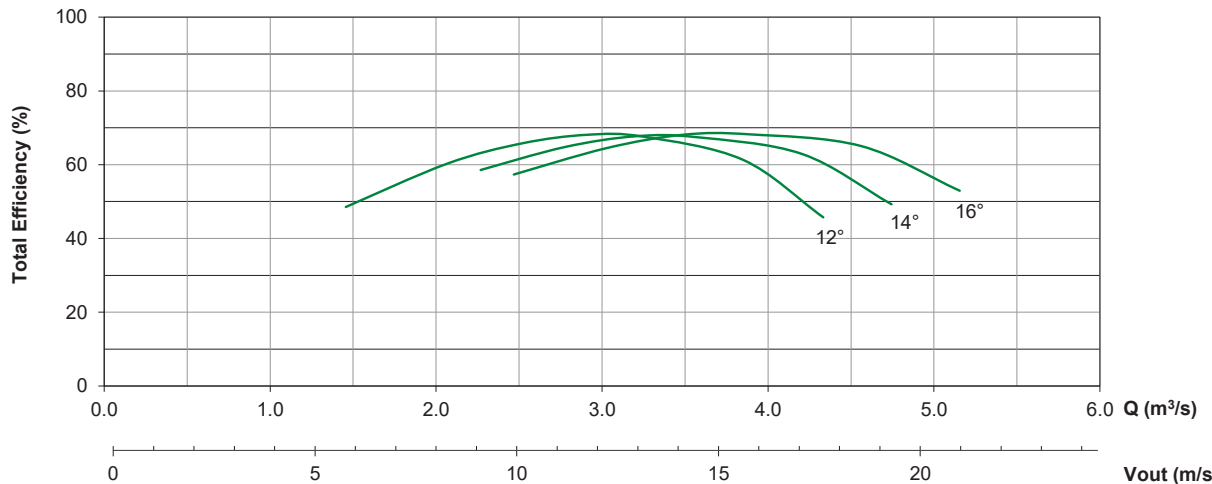
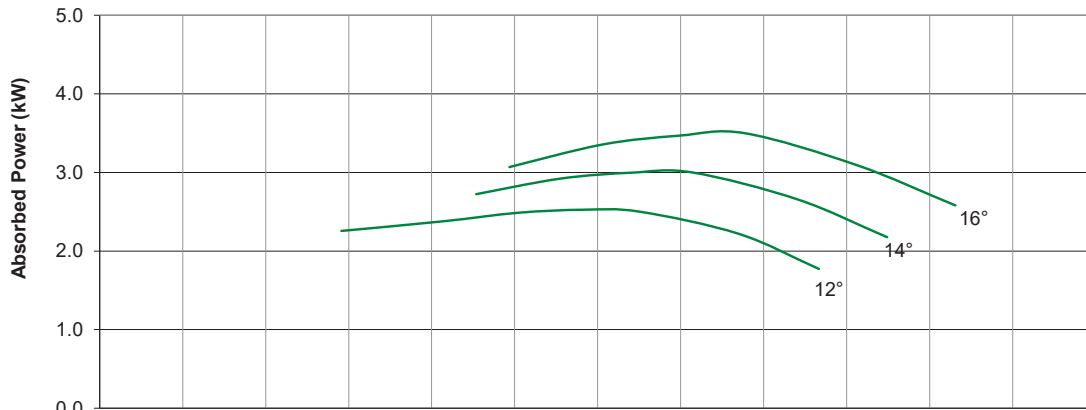
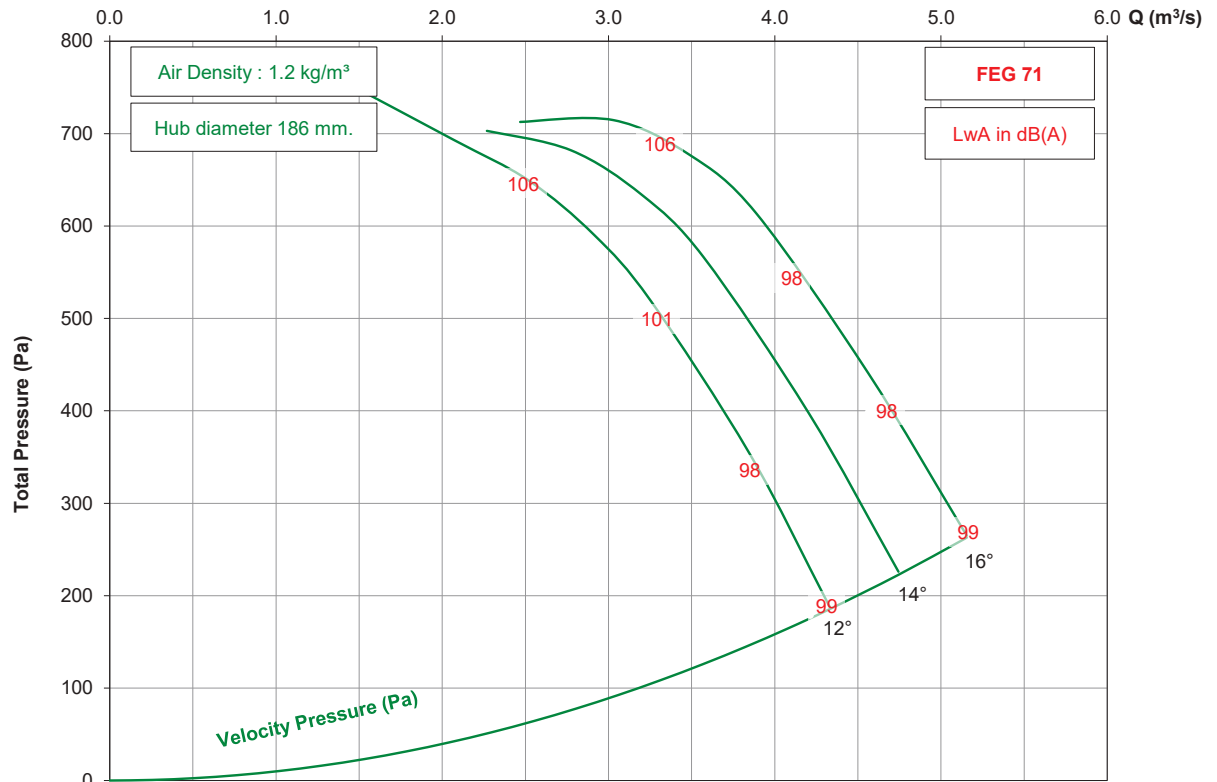

- Performance certified is for installation type D - ducted inlet, ducted outlet. Performance ratings do not include the effects of appurtenances (accessories).  
 - The A-weighted sound ratings shown have been calculated per AMCA International Standard 301. Values shown are for inlet Lwi(A) sound power levels for installation type D - ducted inlet, ducted outlet. Ratings include the effects of duct end correction.

# TDA560 / 9AA / 7-7 (186)

1450 rpm - 50 Hz

KRUGER

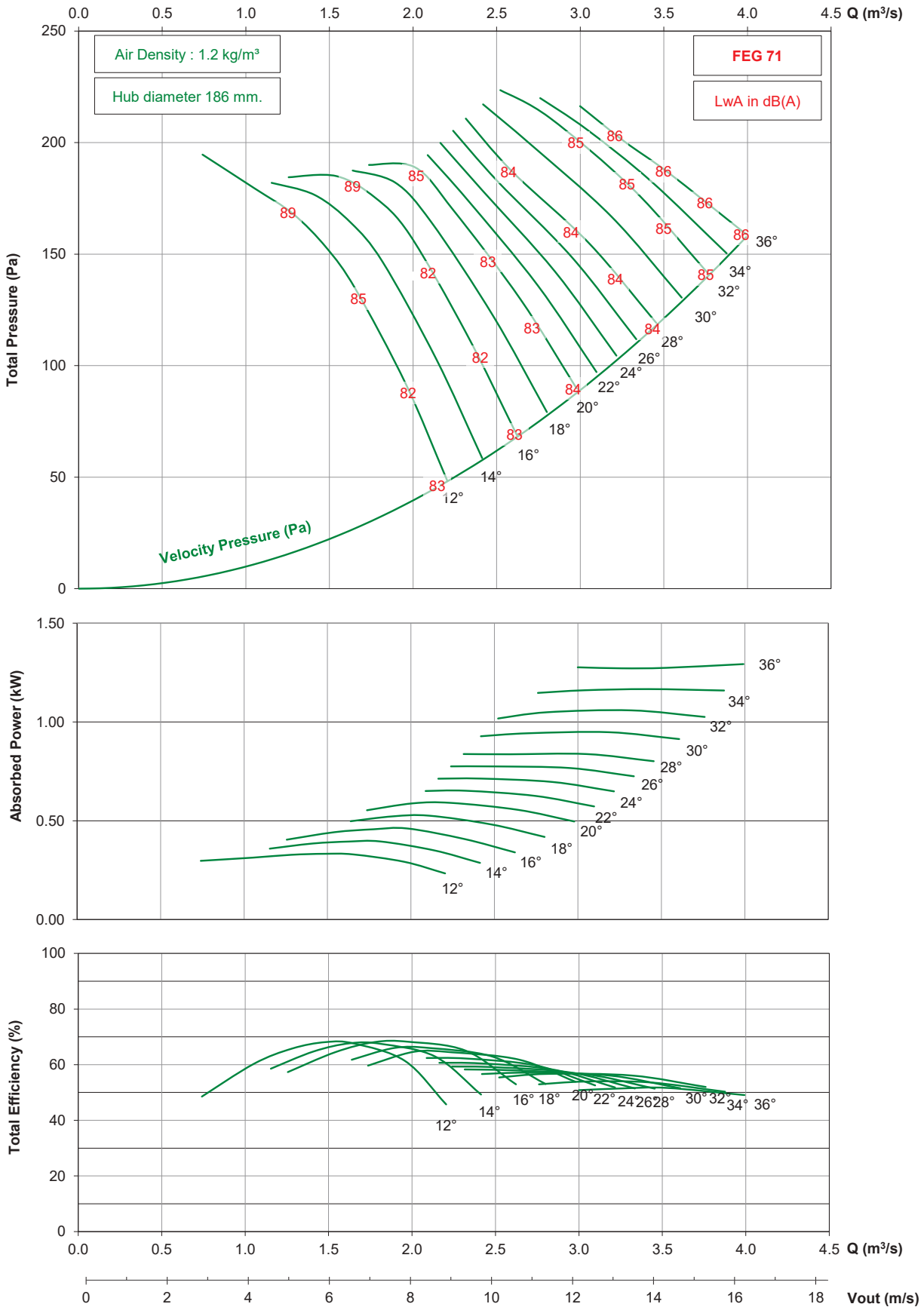

- Performance certified is for installation type D - ducted inlet, ducted outlet. Performance ratings do not include the effects of appurtenances (accessories).  
 - The A-weighted sound ratings shown have been calculated per AMCA International Standard 301. Values shown are for inlet Lwi(A) sound power levels for installation type D - ducted inlet, ducted outlet. Ratings include the effects of duct end correction.

# TDA560 / 9AA / 7-7 (186)

1750 rpm - 60 Hz

KRUGER

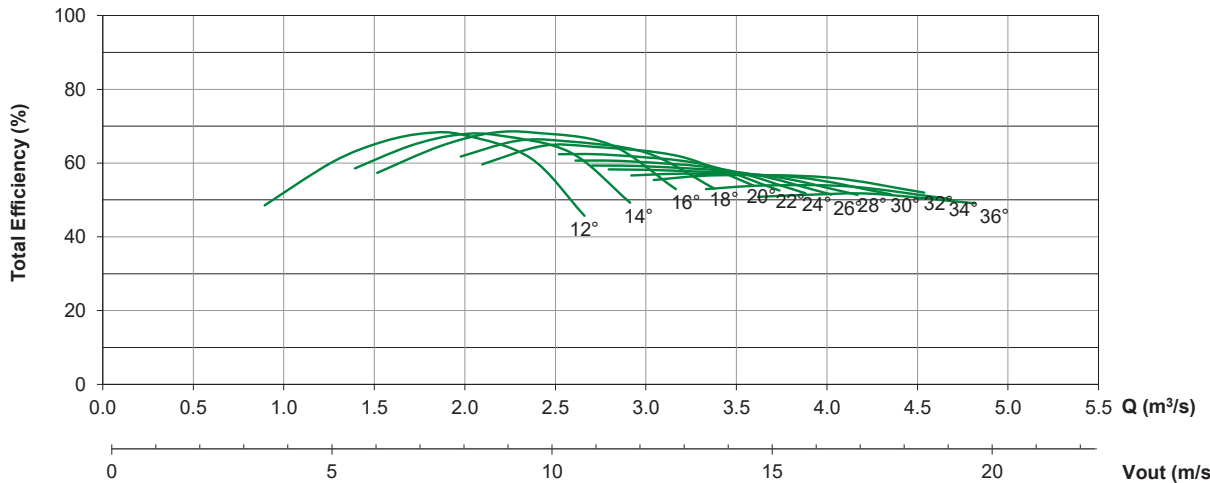
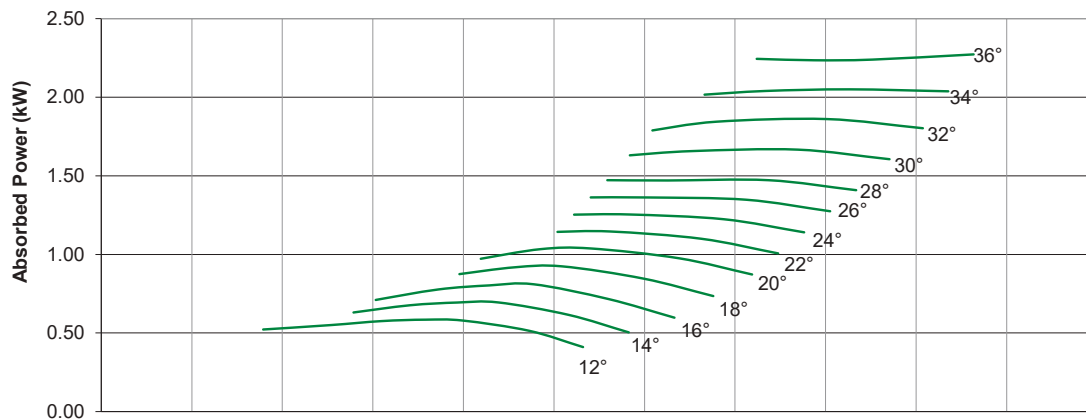
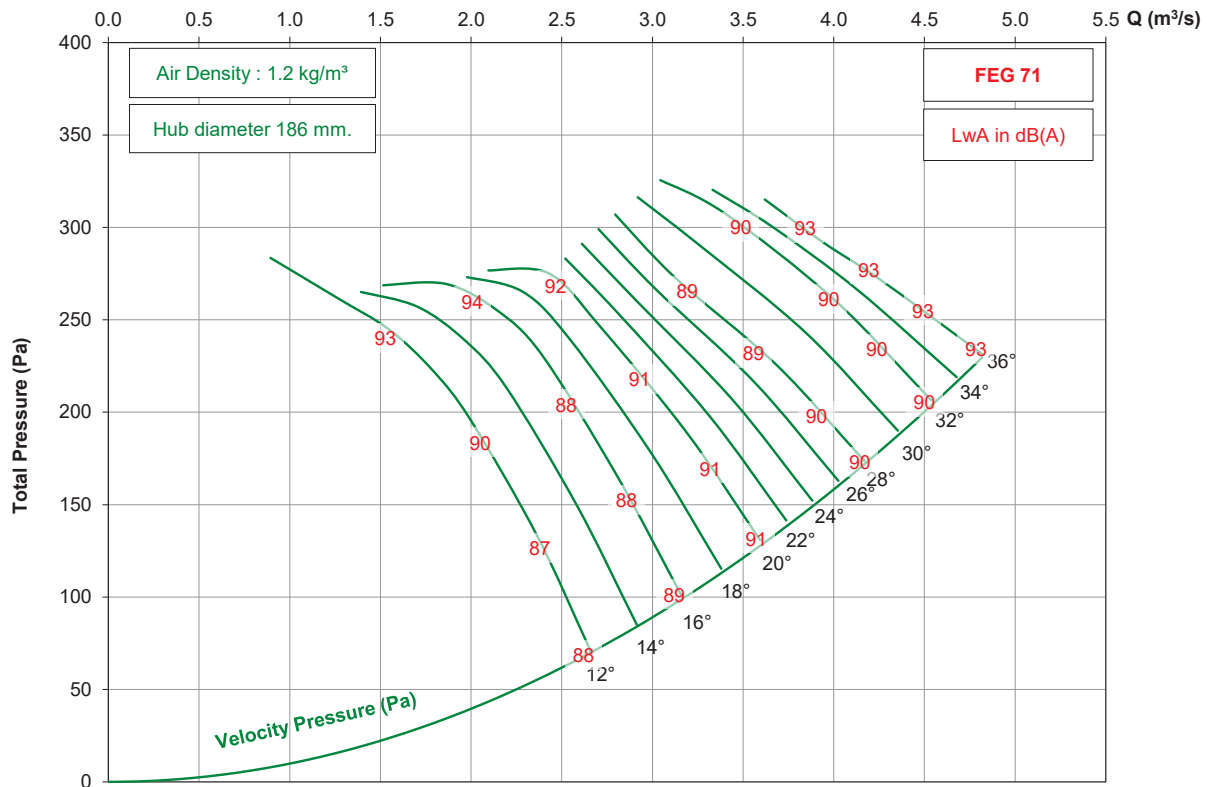

- Performance certified is for installation type D - ducted inlet, ducted outlet. Performance ratings do not include the effects of appurtenances (accessories).

- The A-weighted sound ratings shown have been calculated per AMCA International Standard 301. Values shown are for inlet Lw(A) sound power levels for installation type D - ducted inlet, ducted outlet. Ratings include the effects of duct end correction.

# TDA630 / 12AA / 9-9 (200)

2850 rpm - 50 Hz

KRUGER

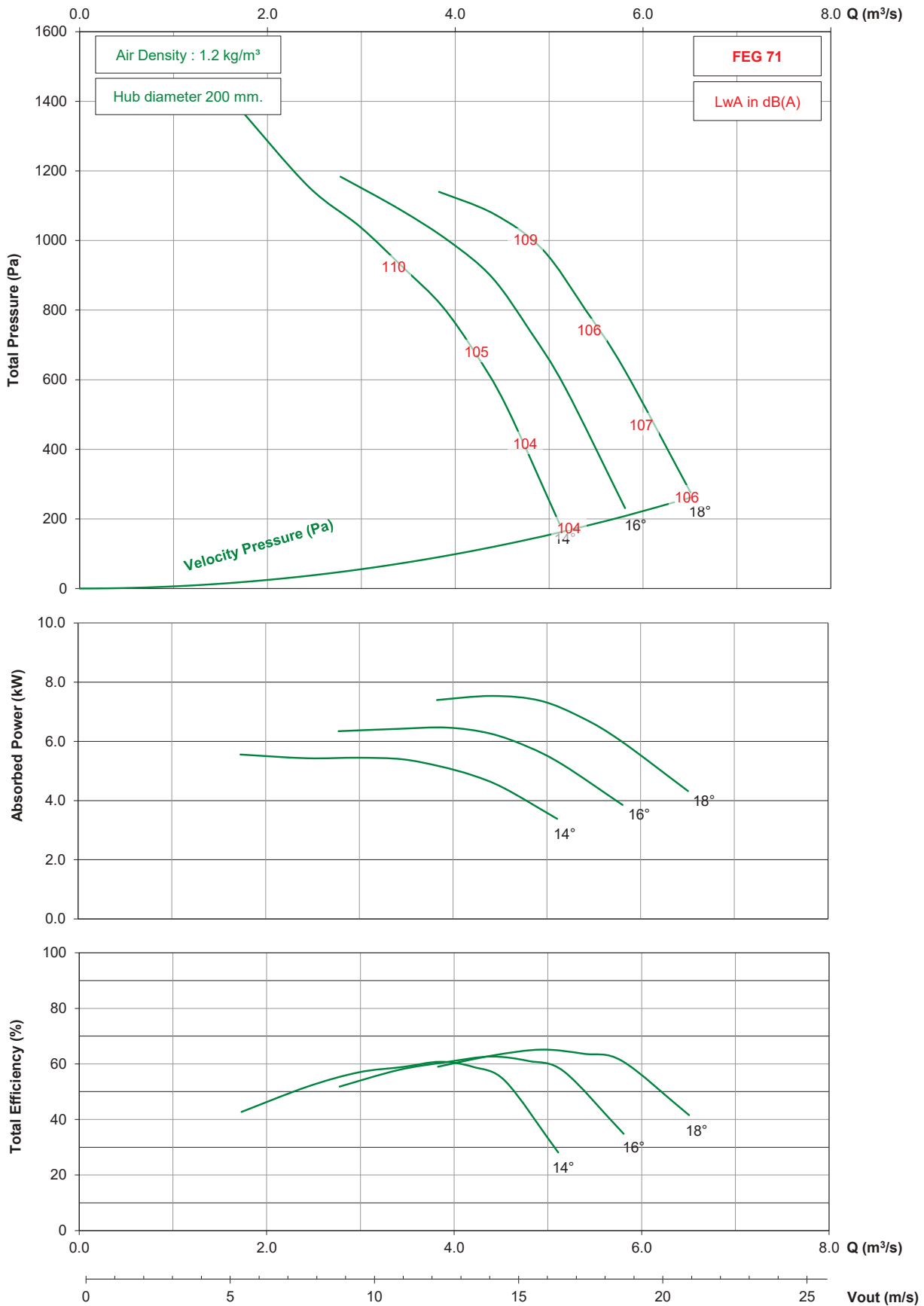

- Performance certified is for installation type D - ducted inlet, ducted outlet. Performance ratings do not include the effects of appurtenances (accessories).  
 - The A-weighted sound ratings shown have been calculated per AMCA International Standard 301. Values shown are for inlet Lwi(A) sound power levels for installation type D - ducted inlet, ducted outlet. Ratings include the effects of duct end correction.

# TDA630 / 12AA / 9-9 (200)

1450 rpm - 50 Hz

KRUGER

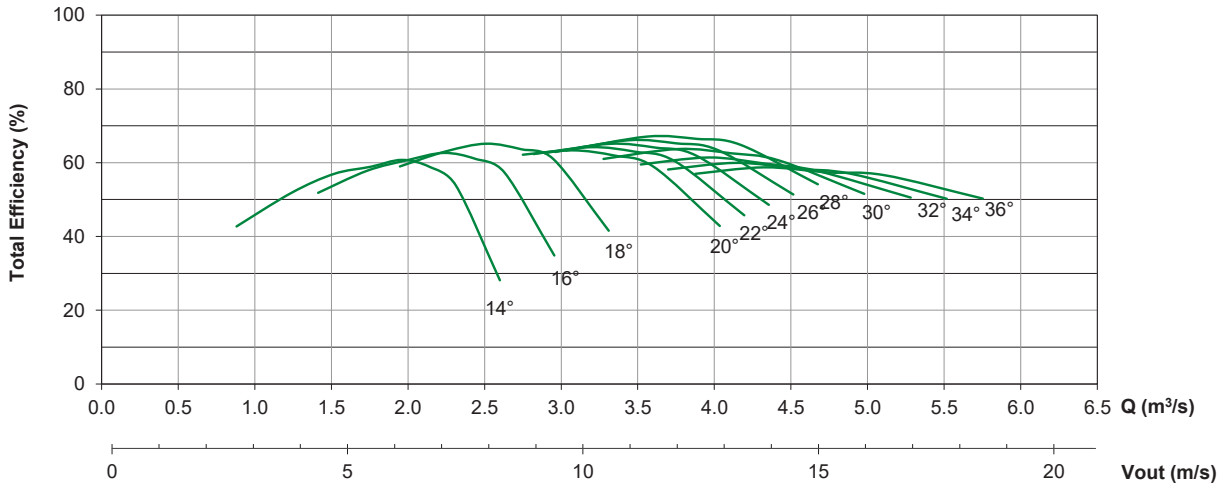
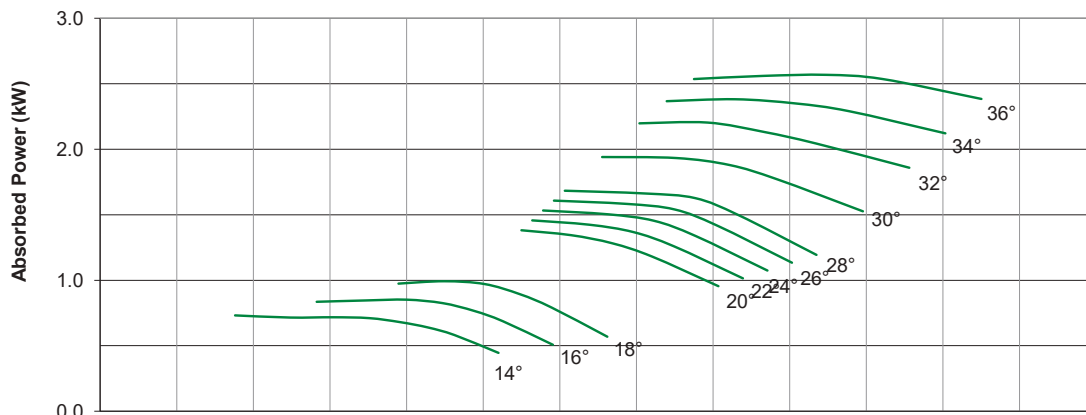
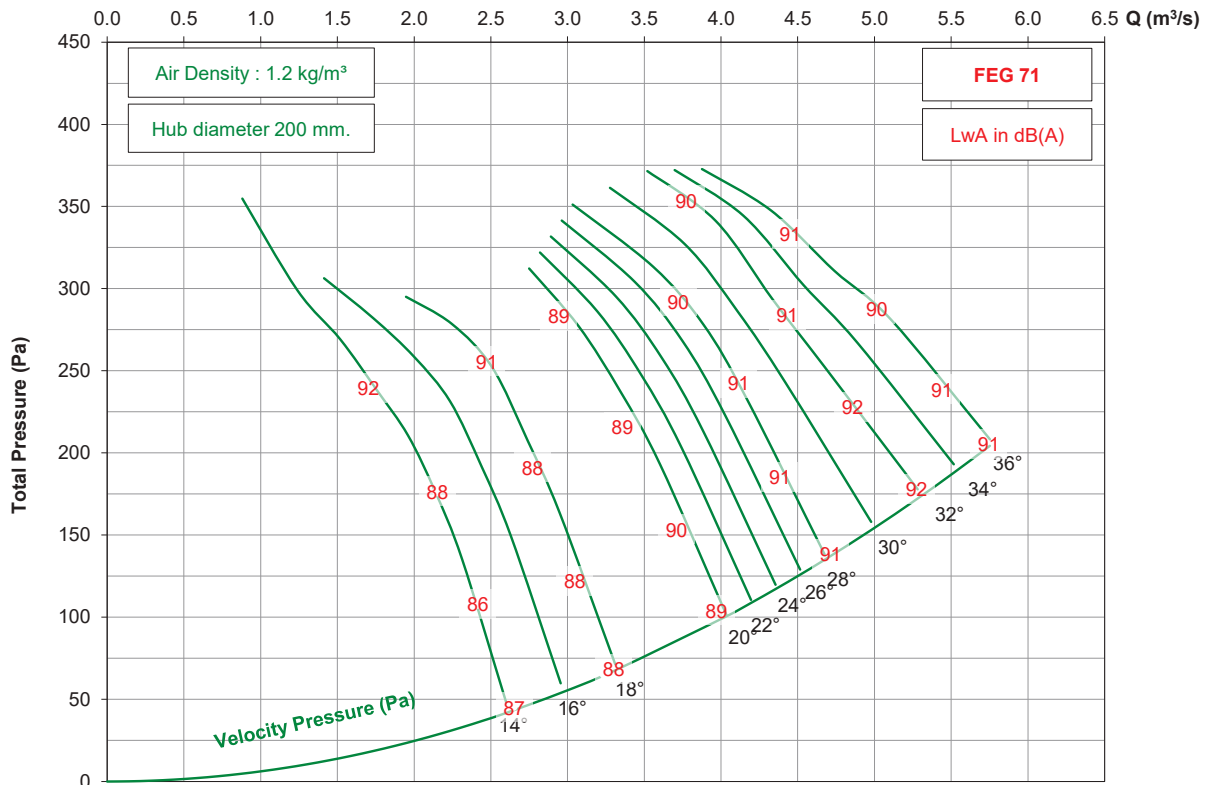

- Performance certified is for installation type D - ducted inlet, ducted outlet. Performance ratings do not include the effects of appurtenances (accessories).

- The A-weighted sound ratings shown have been calculated per AMCA International Standard 301. Values shown are for inlet Lwi(A) sound power levels for installation type D - ducted inlet, ducted outlet. Ratings include the effects of duct end correction.

T  
D  
A  
  
S  
e  
r  
i  
e  
s

# TDA630 / 12AA / 9-9 (200)

950 rpm - 50 Hz

KRUGER

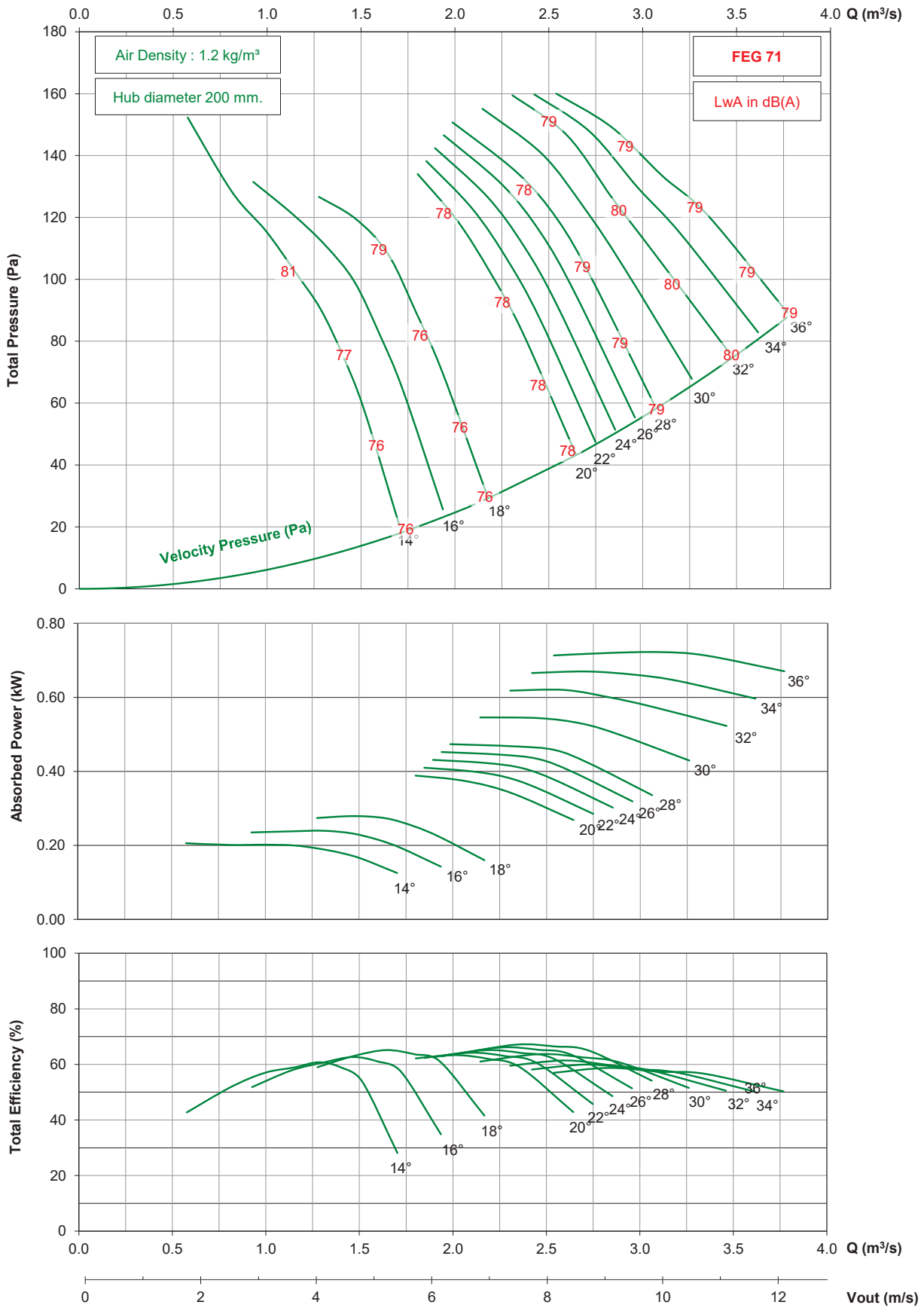

- Performance certified is for installation type D - ducted inlet, ducted outlet. Performance ratings do not include the effects of appurtenances (accessories).  
 - The A-weighted sound ratings shown have been calculated per AMCA International Standard 301. Values shown are for inlet Lwi(A) sound power levels for installation type D - ducted inlet, ducted outlet. Ratings include the effects of duct end correction.

# TDA630 / 12AA / 9-9 (200)

725 rpm - 50 Hz

KRUGER

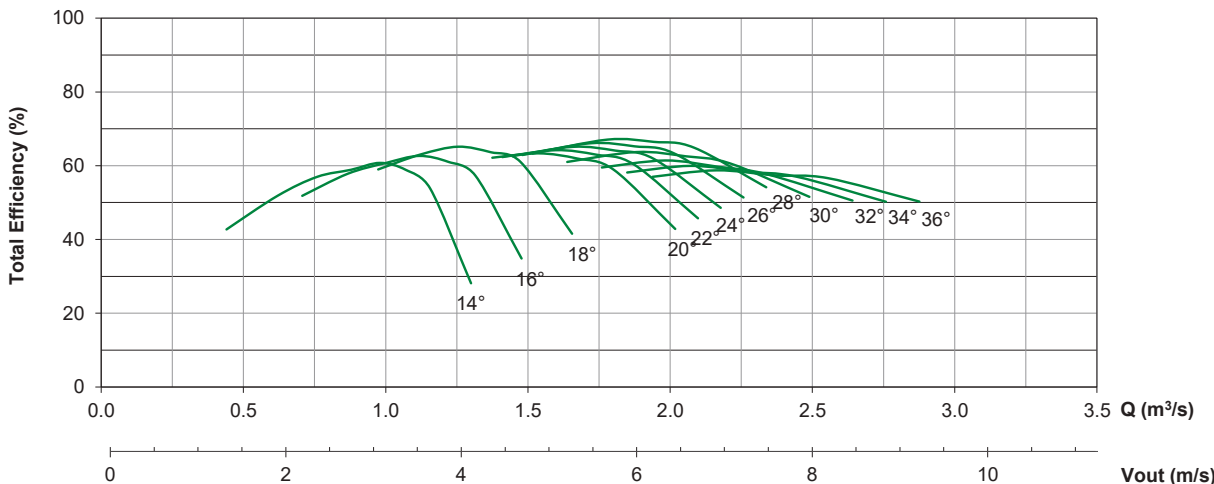
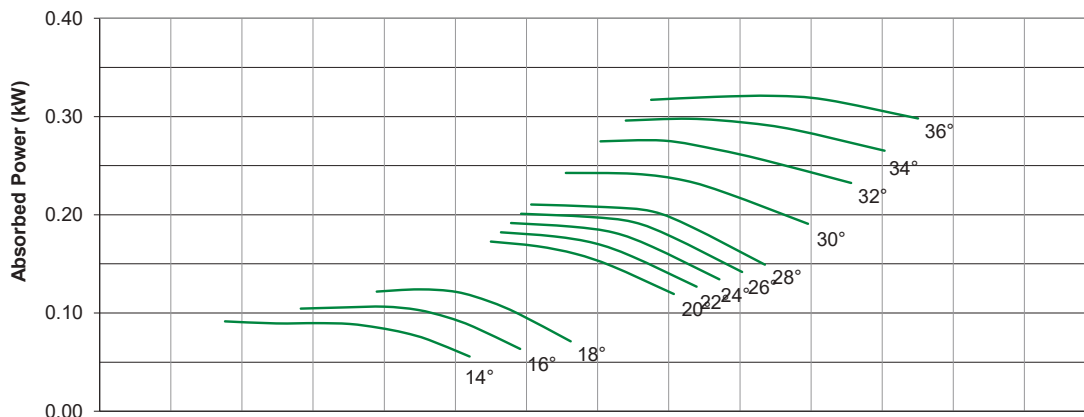
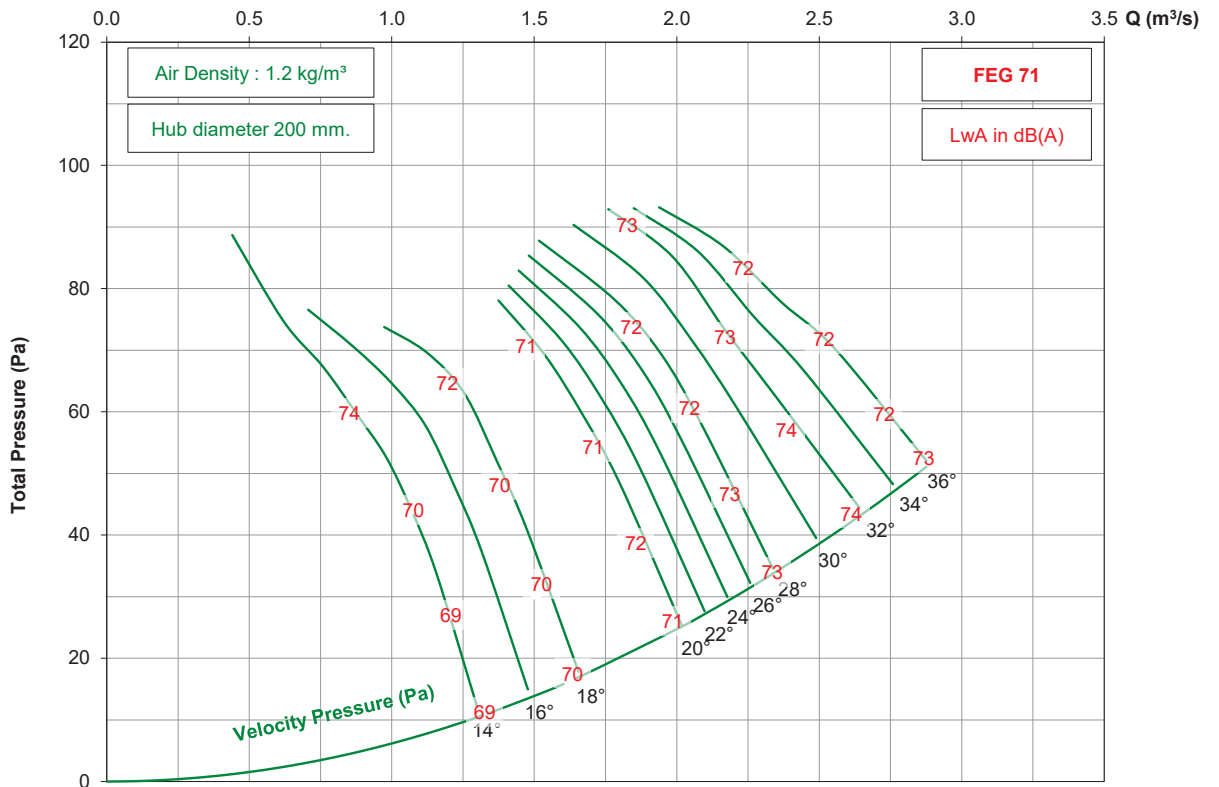

- Performance certified is for installation type D - ducted inlet, ducted outlet. Performance ratings do not include the effects of appurtenances (accessories).  
 - The A-weighted sound ratings shown have been calculated per AMCA International Standard 301. Values shown are for inlet Lwi(A) sound power levels for installation type D - ducted inlet, ducted outlet. Ratings include the effects of duct end correction.

T  
D  
A  
  
S  
e  
r  
i  
e  
s

# TDA630 / 12AA / 9-9 (200)

1750 rpm - 60 Hz

KRUGER

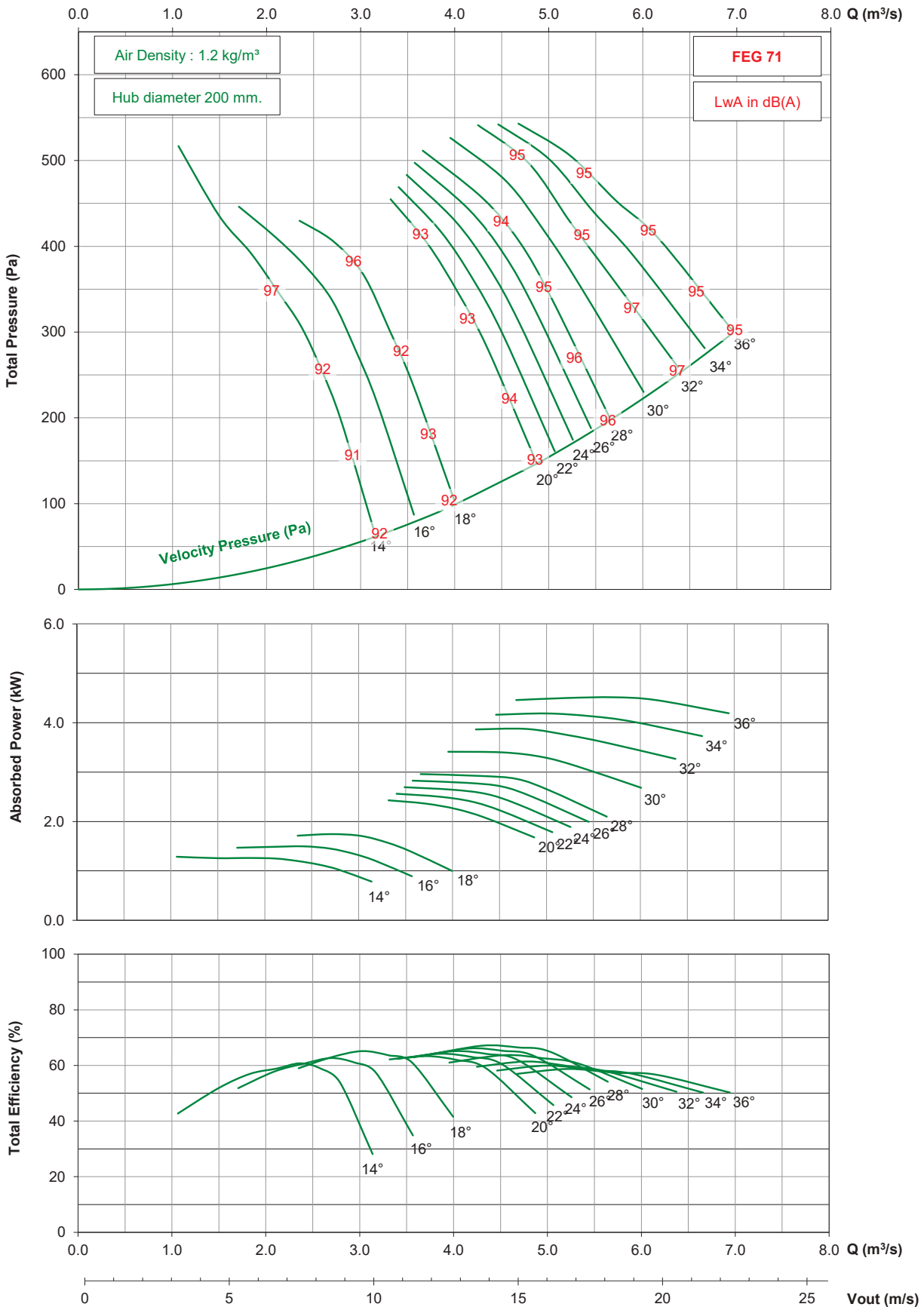

- Performance certified is for installation type D - ducted inlet, ducted outlet. Performance ratings do not include the effects of appurtenances (accessories).  
 - The A-weighted sound ratings shown have been calculated per AMCA International Standard 301. Values shown are for inlet Lw(A) sound power levels for installation type D - ducted inlet, ducted outlet. Ratings include the effects of duct end correction.

TDA Series

# TDA630 / 12AA / 9-9 (200)

1150 rpm - 60 Hz

KRUGER

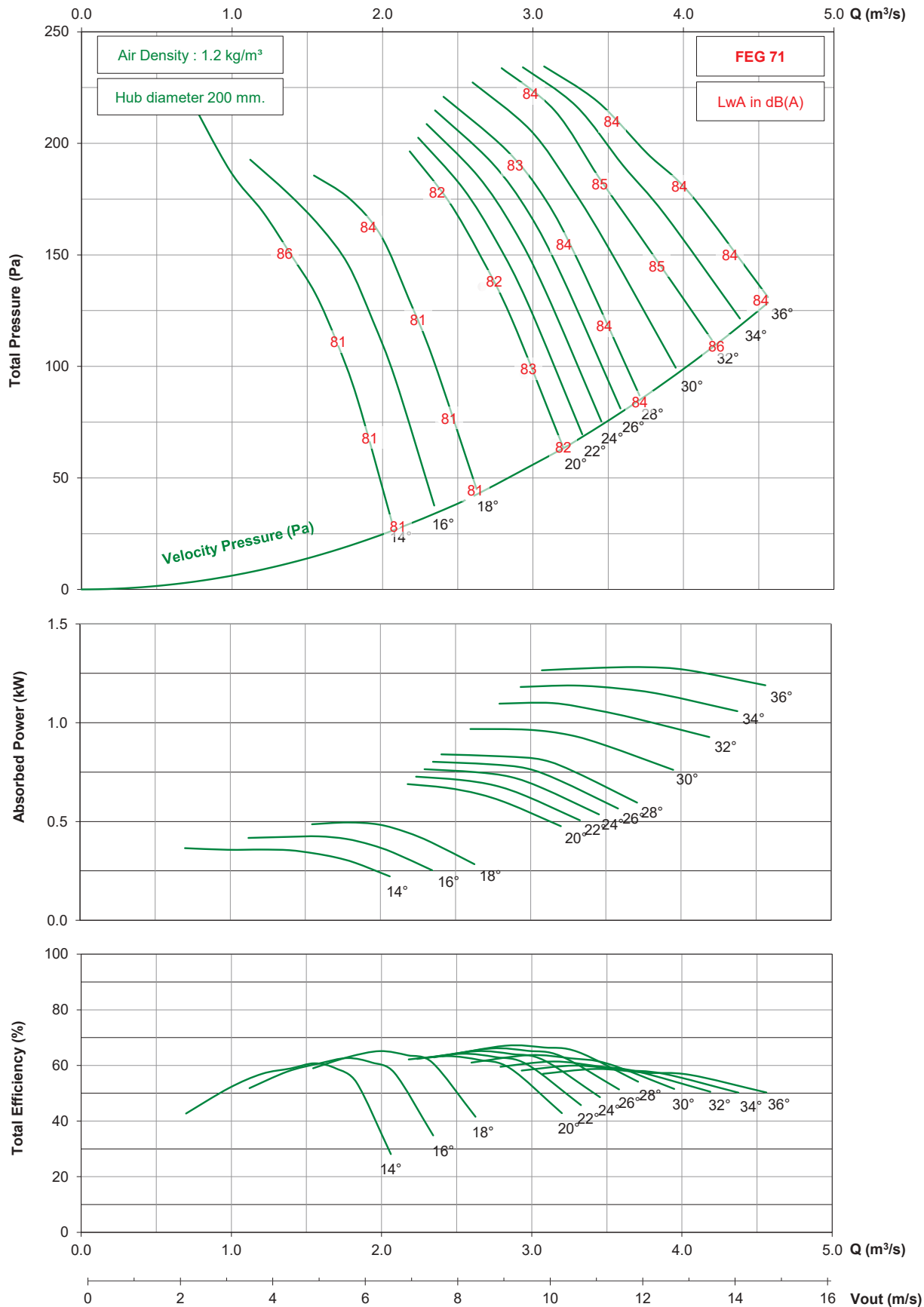

- Performance certified for installation type D - ducted inlet, ducted outlet. Performance ratings do not include the effects of appurtenances (accessories).

- The A-weighted sound ratings shown have been calculated per AMCA International Standard 301. Values shown are for inlet Lwi(A) sound power levels for installation type D - ducted inlet, ducted outlet. Ratings include the effects of duct end correction.

# TDA630 / 12AA / 9-9 (200)

875 rpm - 60 Hz

KRUGER

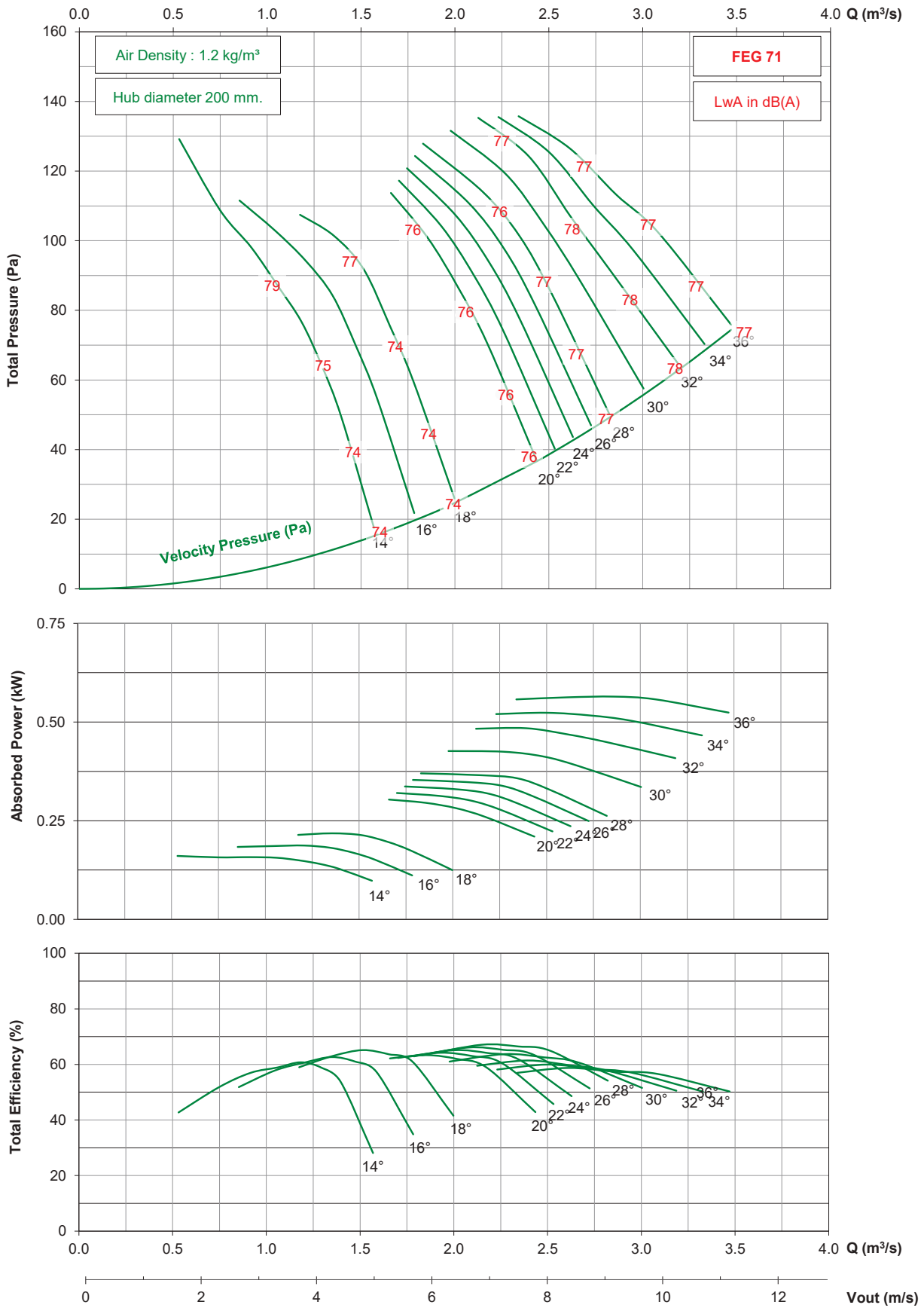

- Performance certified is for installation type D - ducted inlet, ducted outlet. Performance ratings do not include the effects of appurtenances (accessories).  
 - The A-weighted sound ratings shown have been calculated per AMCA International Standard 301. Values shown are for inlet Lwi(A) sound power levels for installation type D - ducted inlet, ducted outlet. Ratings include the effects of duct end correction.

TDA Series

# TDA710 / 12AA / 12-12 (280)

2850 rpm - 50 Hz

KRUGER

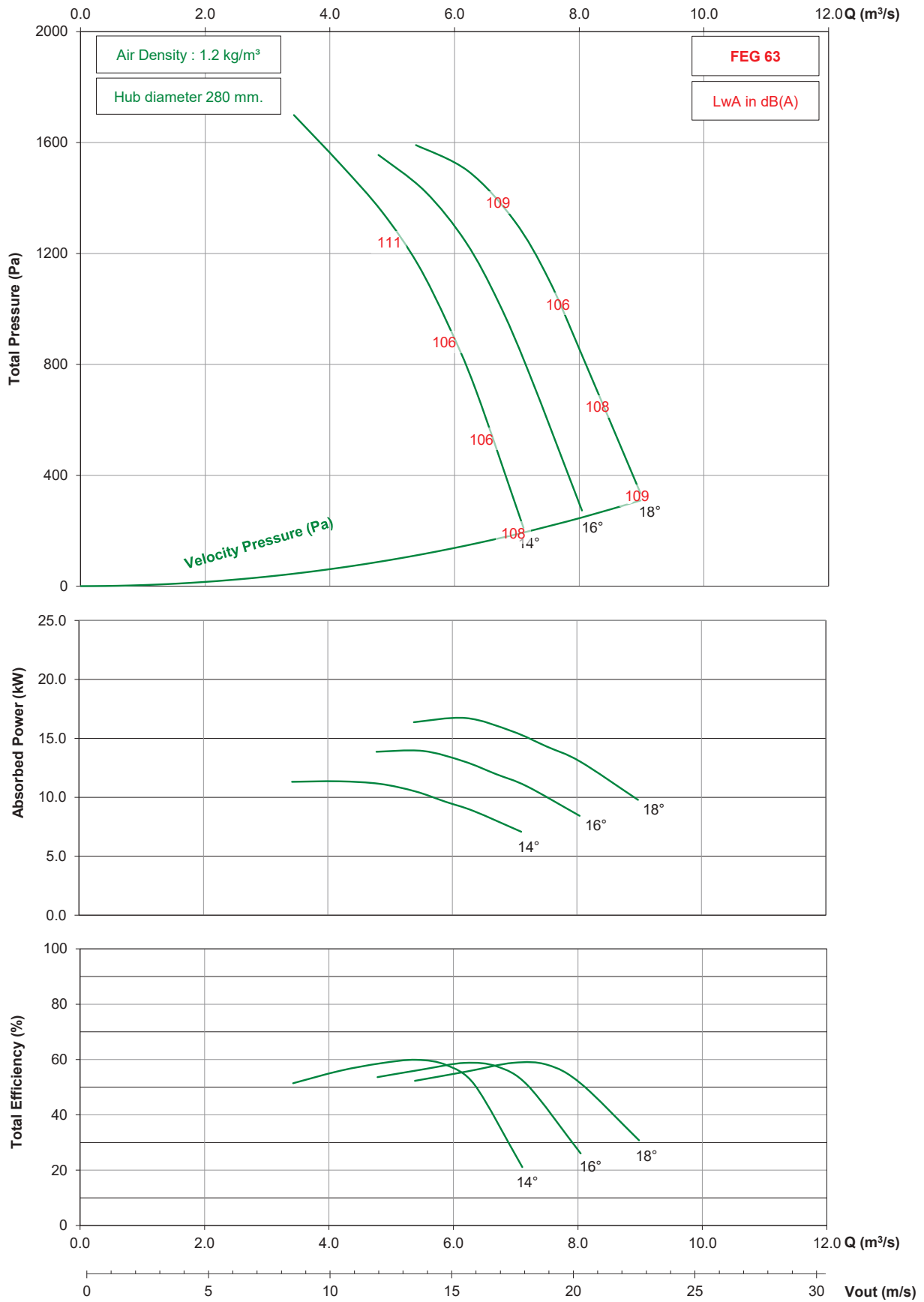

- Performance certified for installation type D - ducted inlet, ducted outlet. Performance ratings do not include the effects of appurtenances (accessories).  
 - The A-weighted sound ratings shown have been calculated per AMCA International Standard 301. Values shown are for inlet Lwi(A) sound power levels for installation type D - ducted inlet, ducted outlet. Ratings include the effects of duct end correction.

# TDA710 / 12AA / 12-12 (280)

1450 rpm - 50 Hz

KRUGER

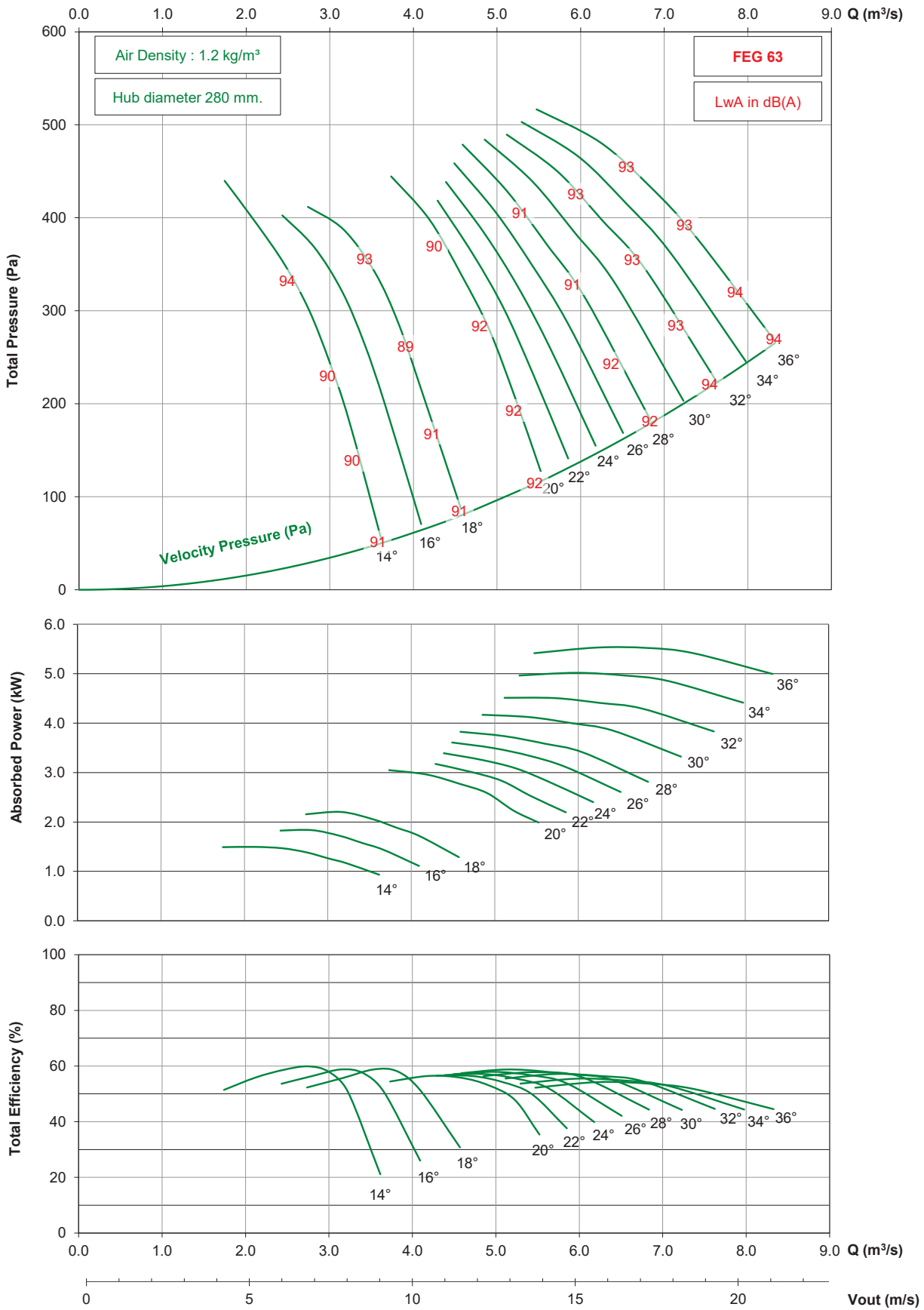

- Performance certified is for installation type D - ducted inlet, ducted outlet. Performance ratings do not include the effects of appurtenances (accessories).  
 - The A-weighted sound ratings shown have been calculated per AMCA International Standard 301. Values shown are for inlet L<sub>wi</sub>(A) sound power levels for installation type D - ducted inlet, ducted outlet. Ratings include the effects of duct end correction.

TDA Series

# TDA710 / 12AA / 12-12 (280)

950 rpm - 50 Hz

KRUGER

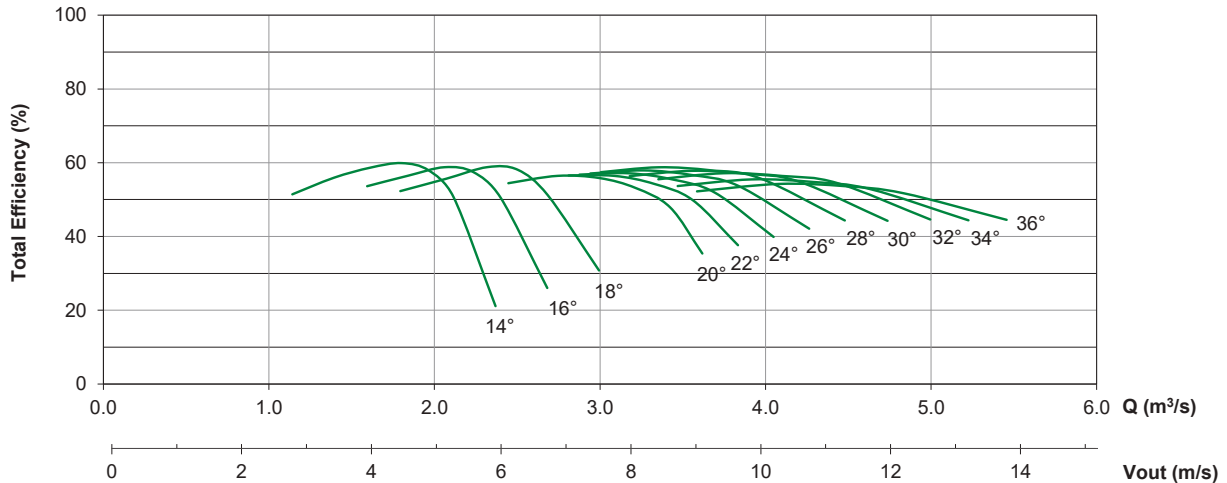
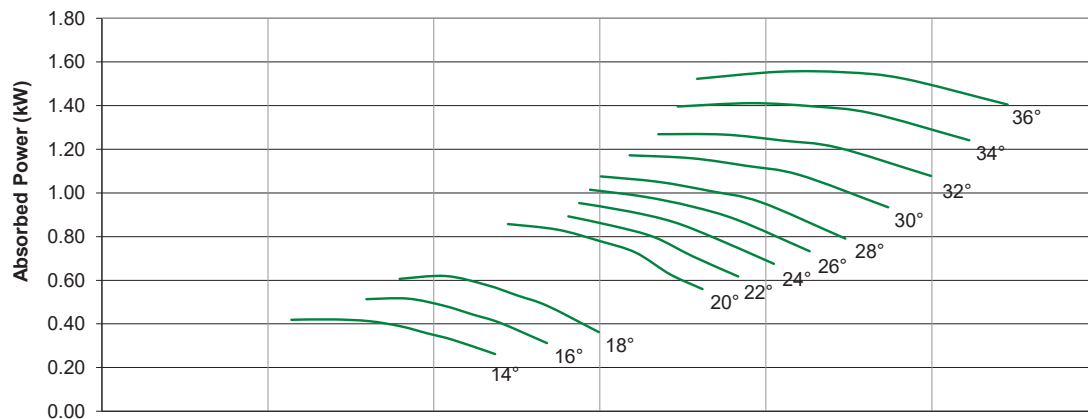
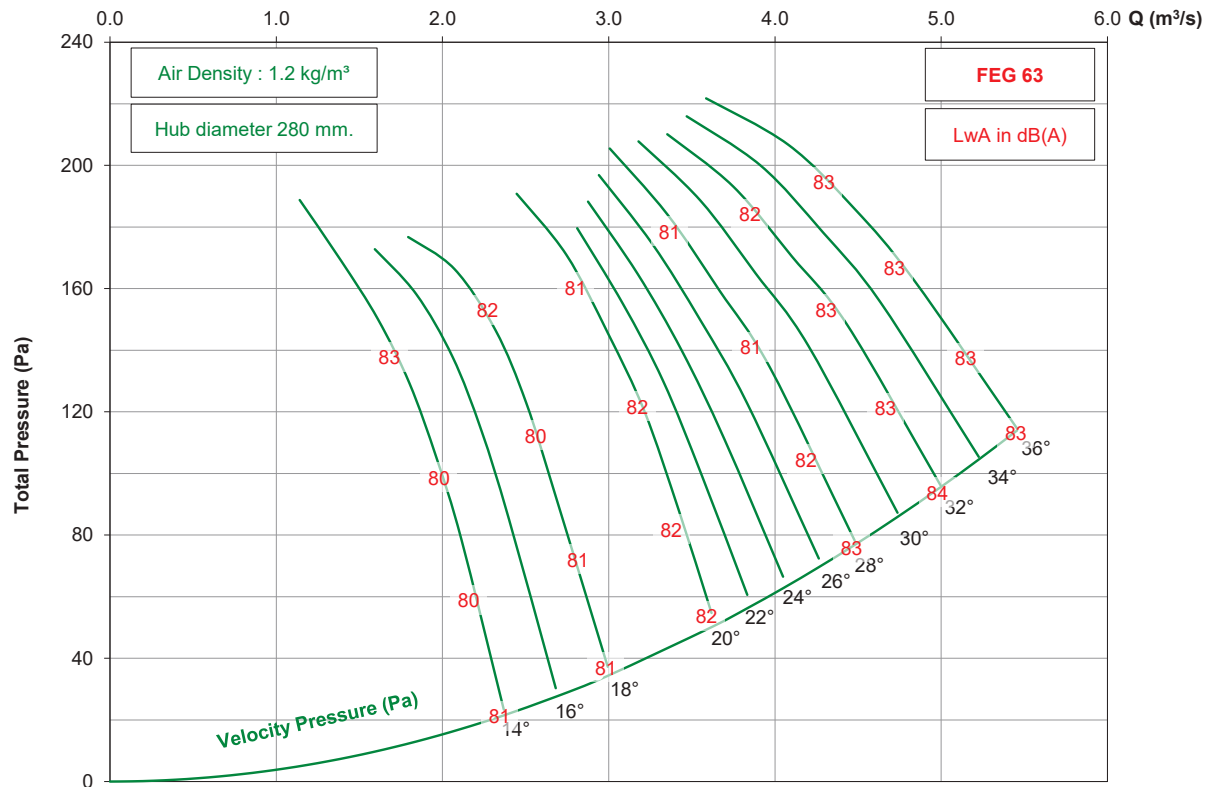

- Performance certified for installation type D - ducted inlet, ducted outlet. Performance ratings do not include the effects of appurtenances (accessories).  
 - The A-weighted sound ratings shown have been calculated per AMCA International Standard 301. Values shown are for inlet Lwi(A) sound power levels for installation type D - ducted inlet, ducted outlet. Ratings include the effects of duct end correction.

T  
D  
A  
  
S  
e  
r  
i  
e  
s

# TDA710 / 12AA / 12-12 (280)

725 rpm - 50 Hz

KRUGER

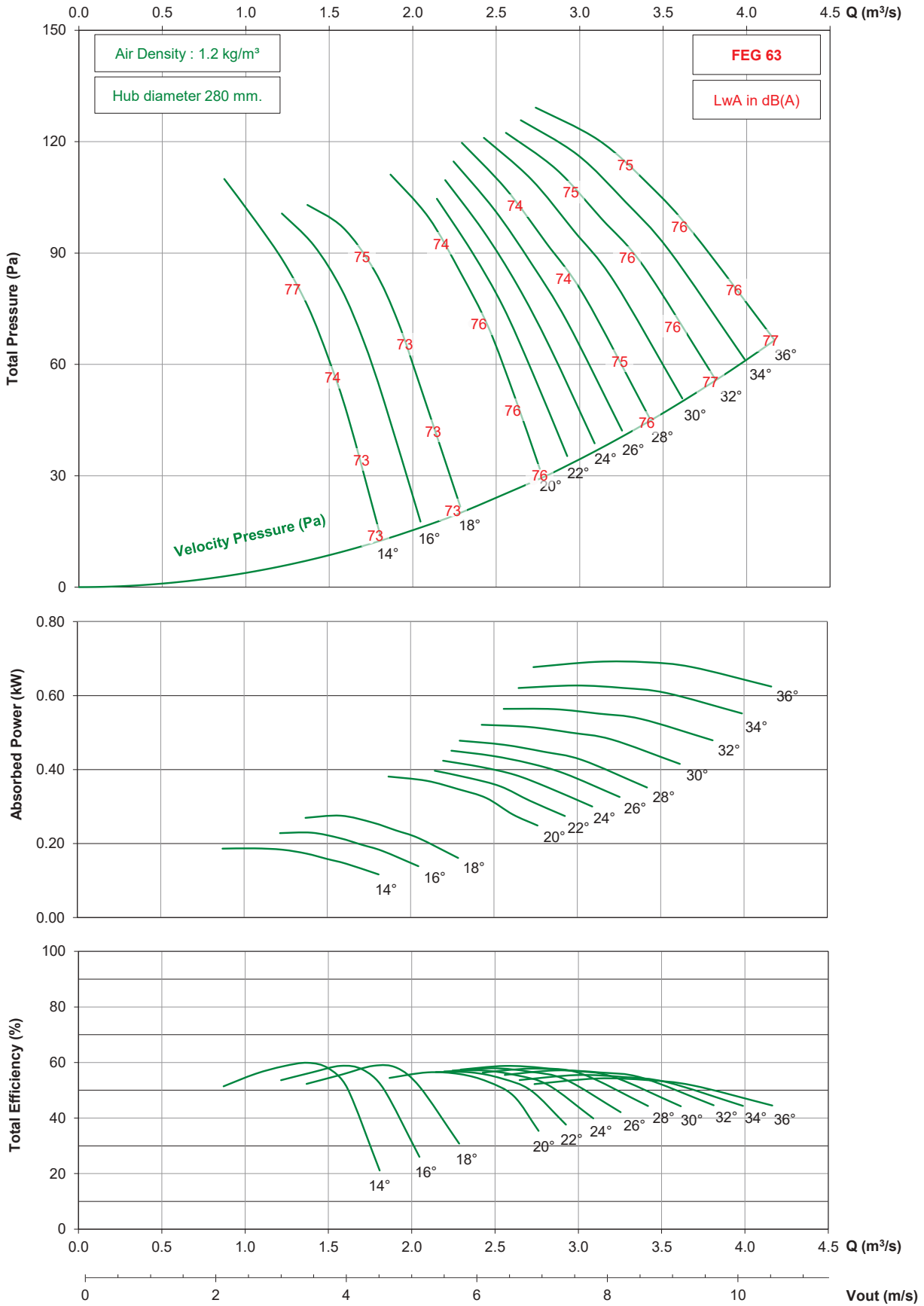

- Performance certified is for installation type D - ducted inlet, ducted outlet. Performance ratings do not include the effects of appurtenances (accessories).  
 - The A-weighted sound ratings shown have been calculated per AMCA International Standard 301. Values shown are for inlet Lw(A) sound power levels for installation type D - ducted inlet, ducted outlet. Ratings include the effects of duct end correction.

TDA Series

# TDA710 / 12AA / 12-12 (280)

1750 rpm - 60 Hz

KRUGER

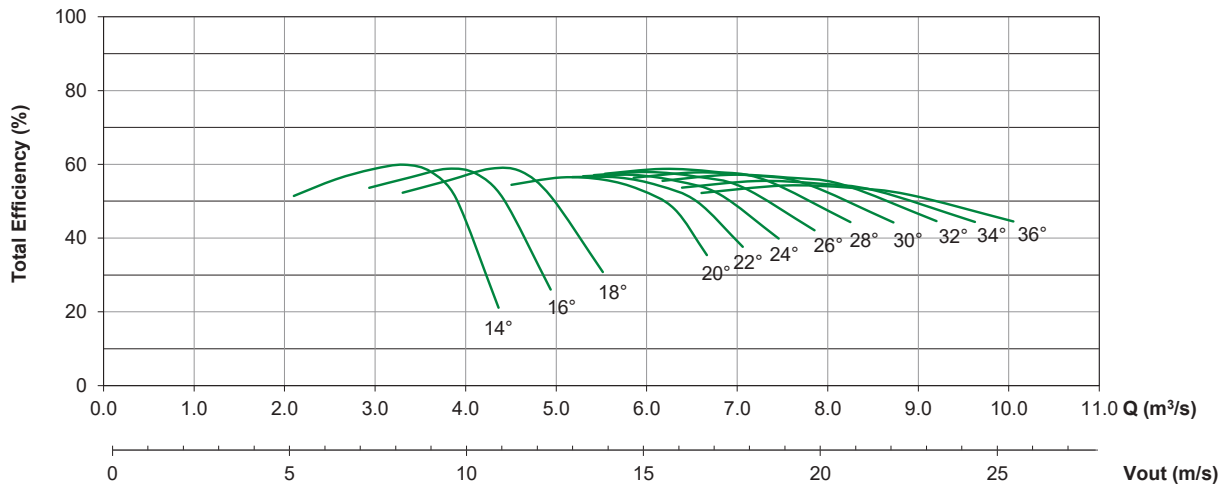
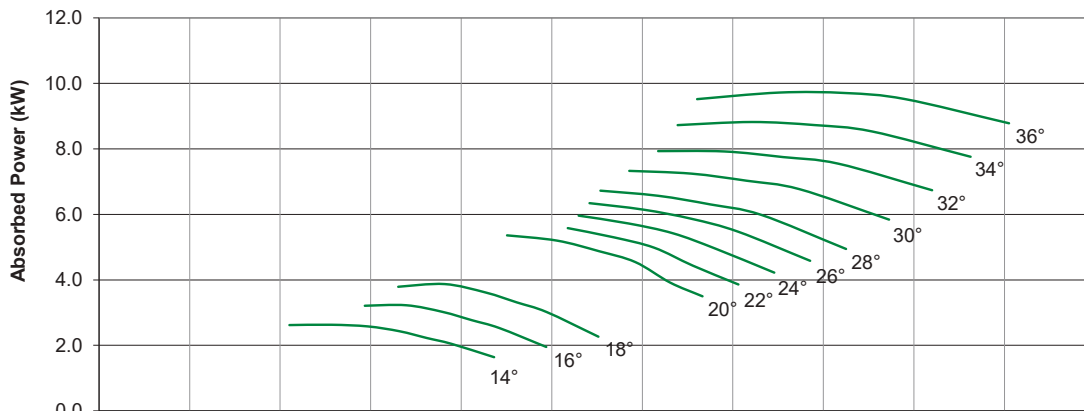
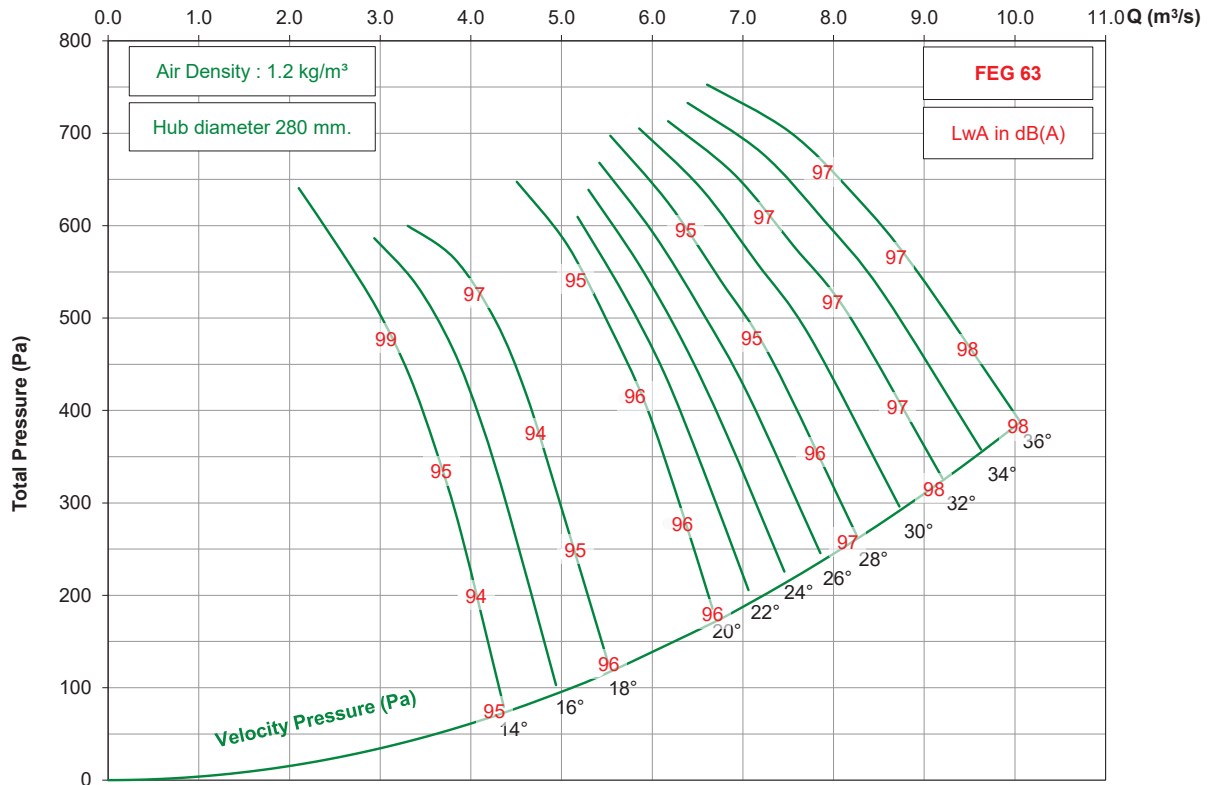

- Performance certified is for installation type D - ducted inlet, ducted outlet. Performance ratings do not include the effects of appurtenances (accessories).  
 - The A-weighted sound ratings shown have been calculated per AMCA International Standard 301. Values shown are for inlet Lwi(A) sound power levels for installation type D - ducted inlet, ducted outlet. Ratings include the effects of duct end correction.

# TDA710 / 12AA / 12-12 (280)

1150 rpm - 60 Hz

KRUGER

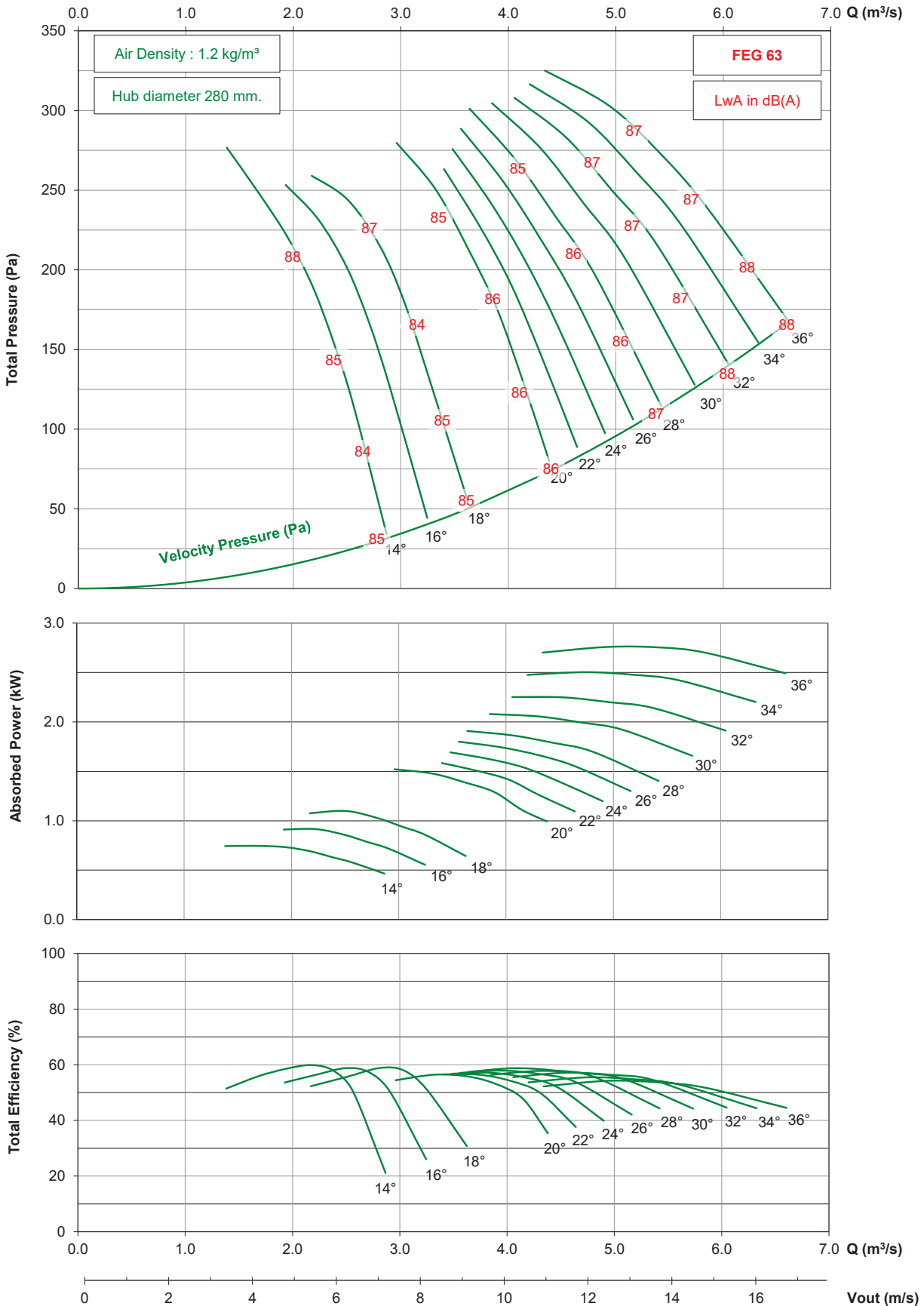

- Performance certified for installation type D - ducted inlet, ducted outlet. Performance ratings do not include the effects of appurtenances (accessories).  
 - The A-weighted sound ratings shown have been calculated per AMCA International Standard 301. Values shown are for inlet Lw(A) sound power levels for installation type D - ducted inlet, ducted outlet. Ratings include the effects of duct end correction.

TDA Series

# TDA710 / 12AA / 12-12 (280)

875 rpm - 60 Hz

KRUGER

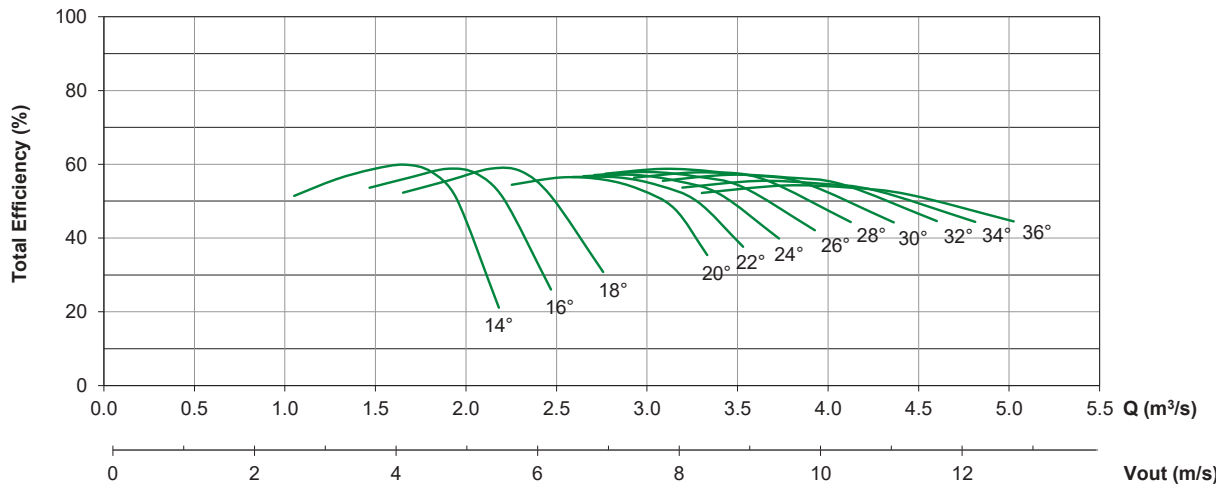
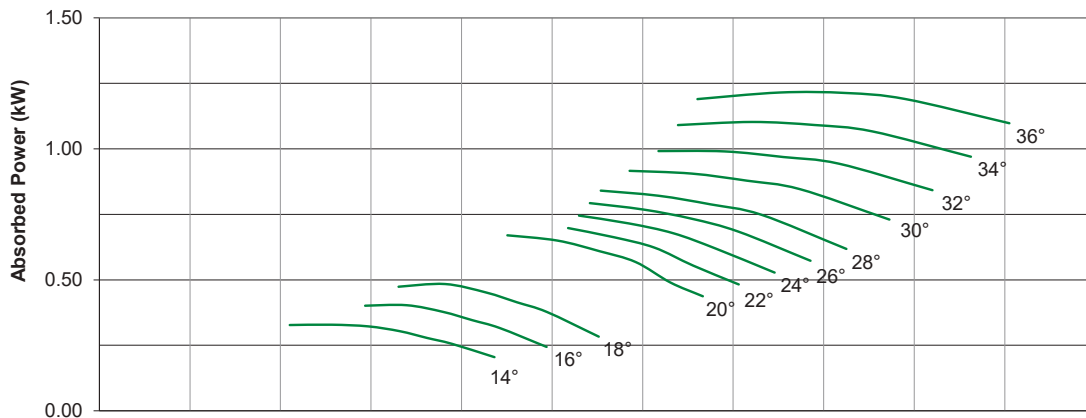
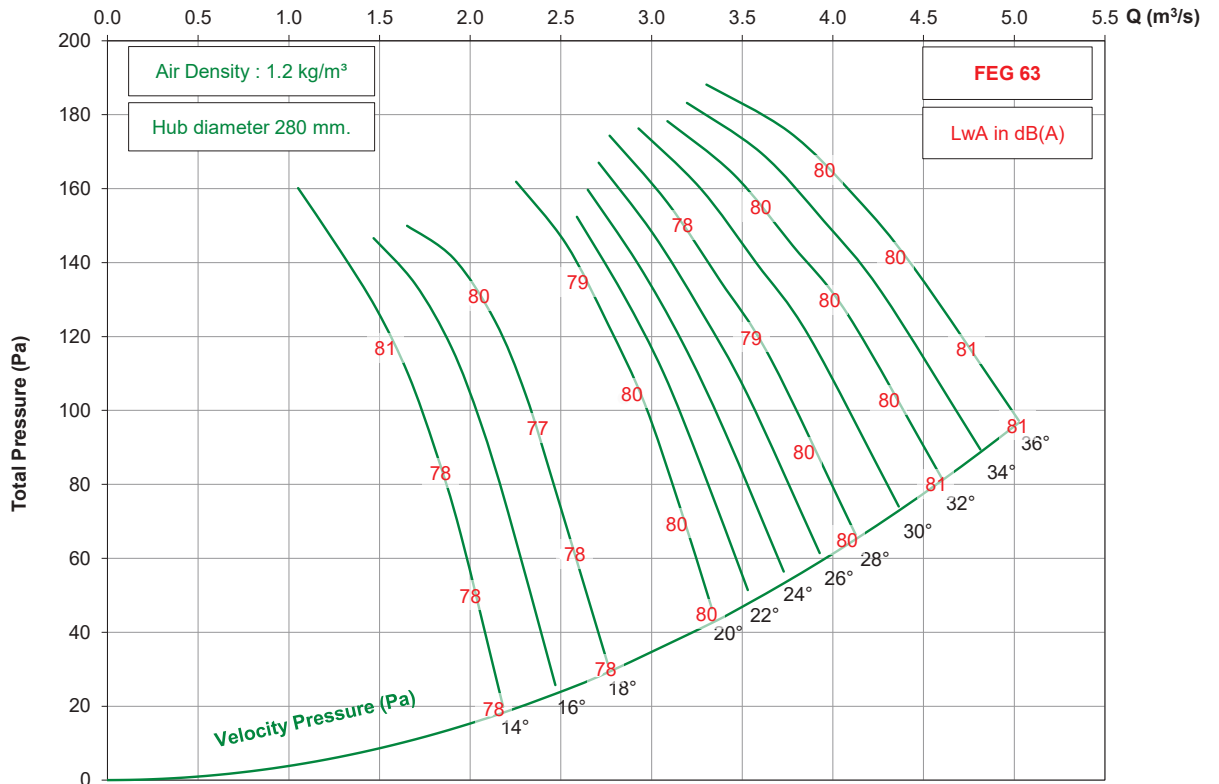

- Performance certified is for installation type D - ducted inlet, ducted outlet. Performance ratings do not include the effects of appurtenances (accessories).  
 - The A-weighted sound ratings shown have been calculated per AMCA International Standard 301. Values shown are for inlet Lwi(A) sound power levels for installation type D - ducted inlet, ducted outlet. Ratings include the effects of duct end correction.

T  
D  
A  
  
S  
e  
r  
i  
e  
s



# TDA800 / 12AA / 12-12 (280)

950 rpm - 50 Hz

KRUGER

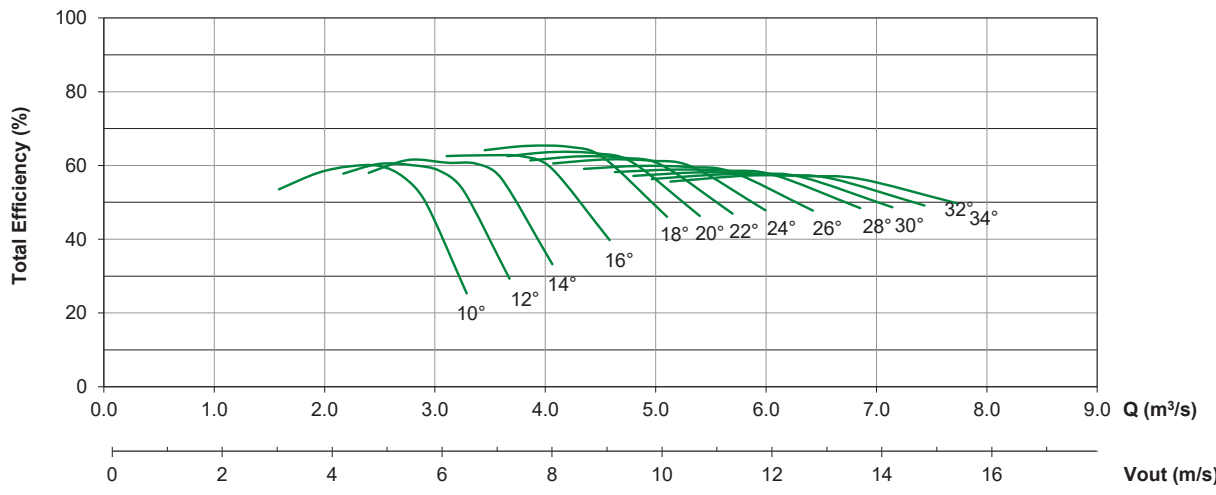
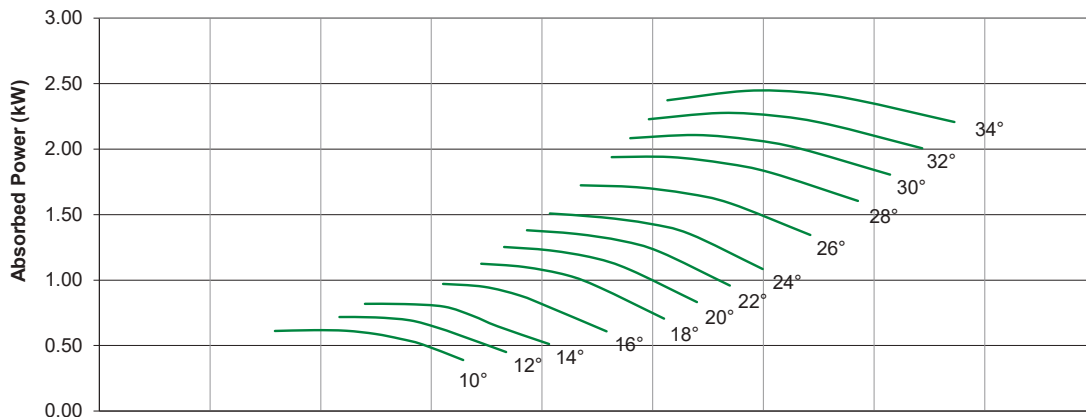
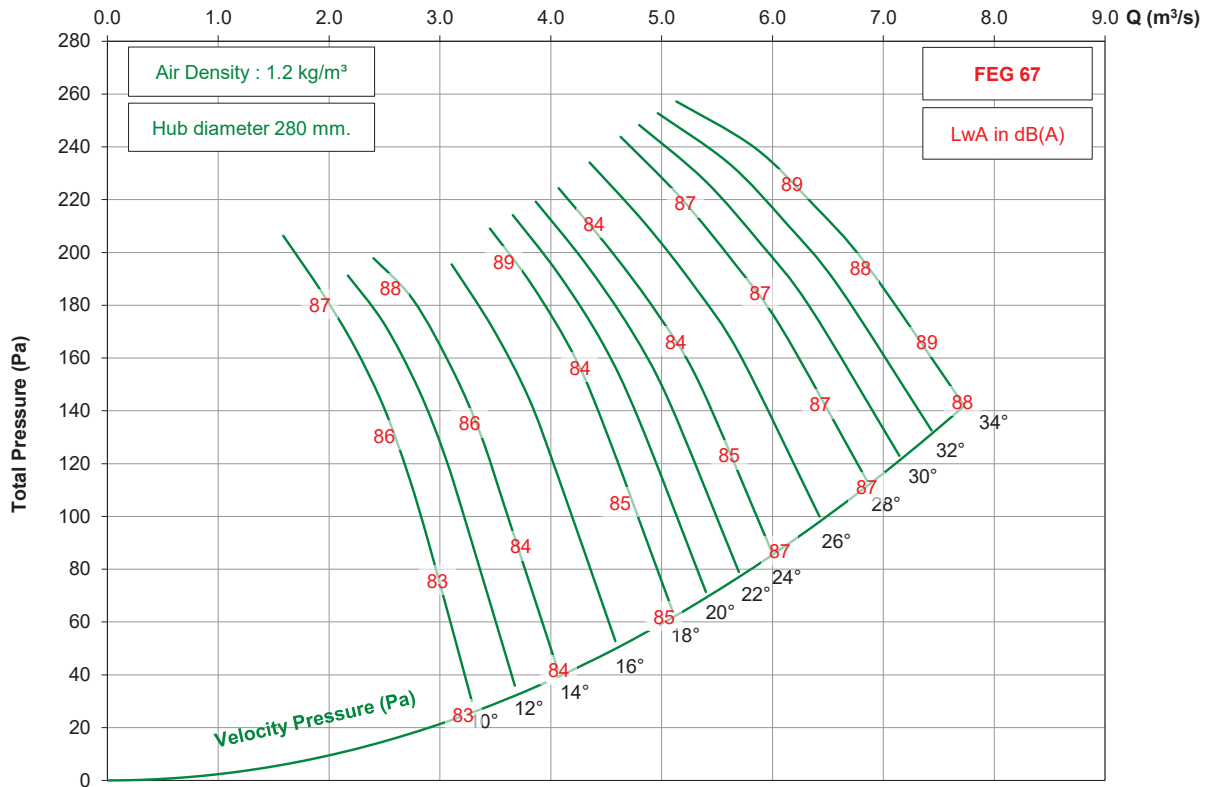

- Performance certified is for installation type D - ducted inlet, ducted outlet. Performance ratings do not include the effects of appurtenances (accessories).  
 - The A-weighted sound ratings shown have been calculated per AMCA International Standard 301. Values shown are for inlet Lw(A) sound power levels for installation type D - ducted inlet, ducted outlet. Ratings include the effects of duct end correction.

T  
D  
A  
  
S  
e  
r  
i  
e  
s

# TDA800 / 12AA / 12-12 (280)

725 rpm - 50 Hz

KRUGER

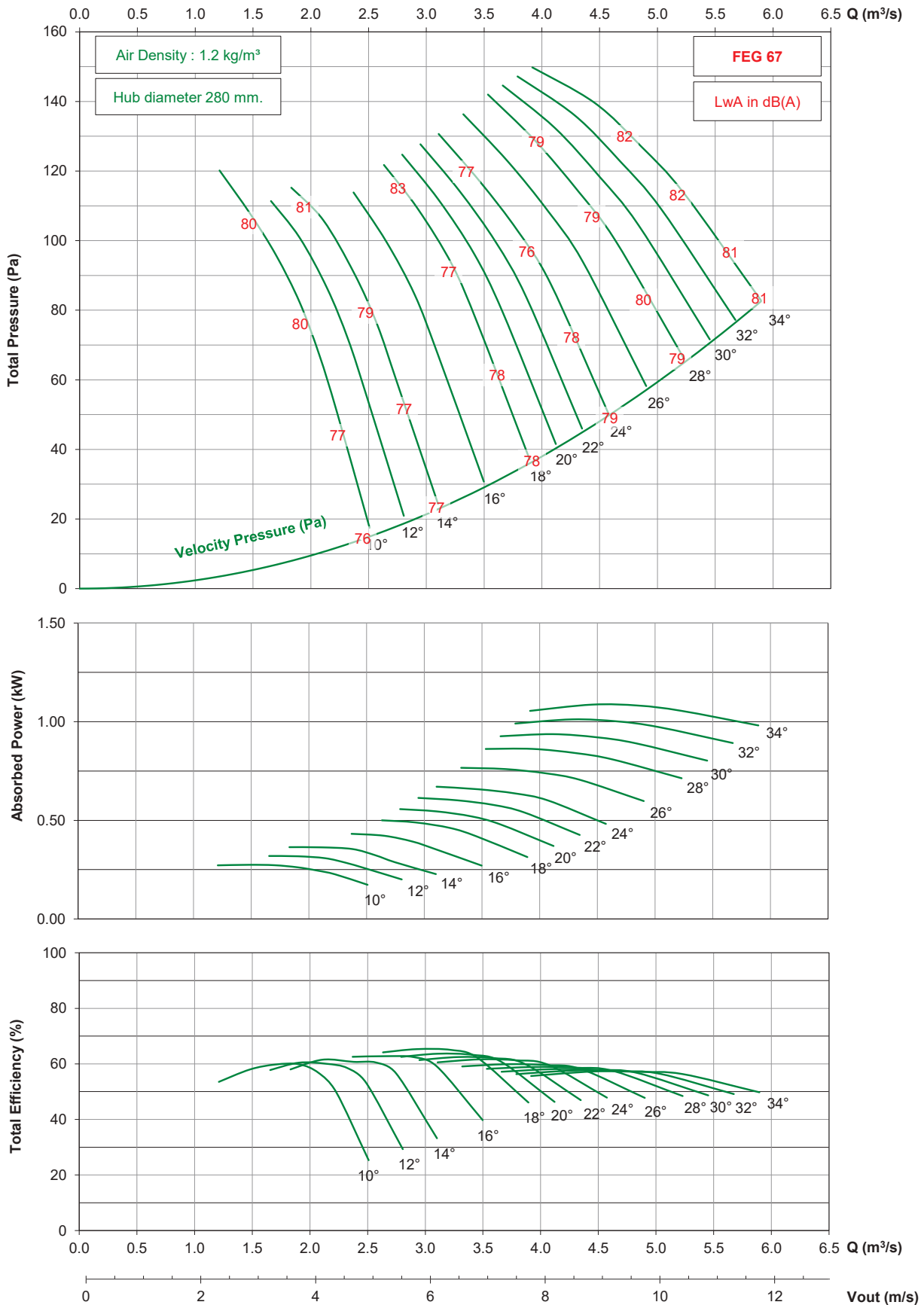

- Performance certified is for installation type D - ducted inlet, ducted outlet. Performance ratings do not include the effects of appurtenances (accessories).  
 - The A-weighted sound ratings shown have been calculated per AMCA International Standard 301. Values shown are for inlet Lwi(A) sound power levels for installation type D - ducted inlet, ducted outlet. Ratings include the effects of duct end correction.

TDA Series

# TDA800 / 12AA / 12-12 (280)

1750 rpm - 60 Hz

KRUGER

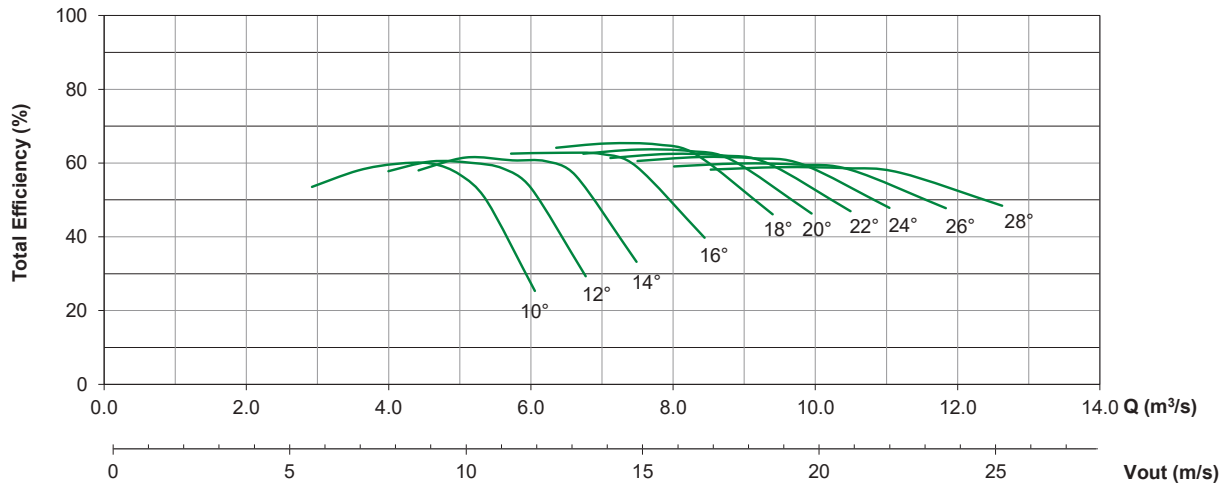
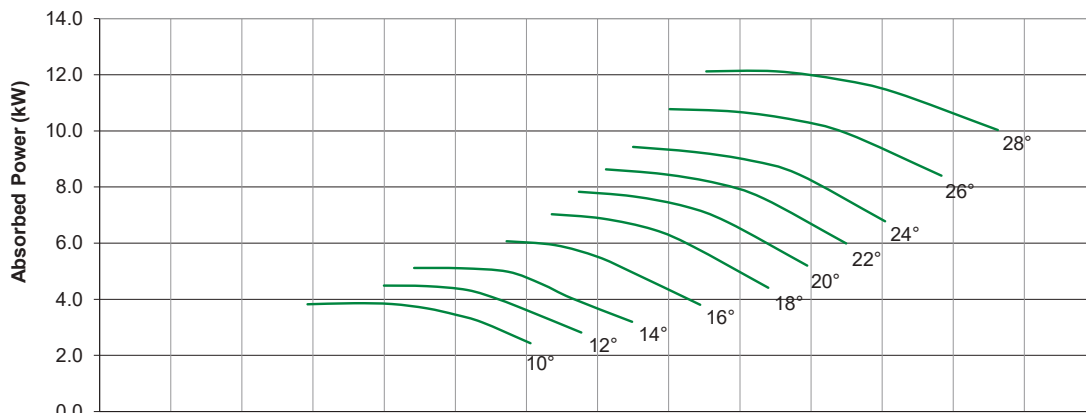
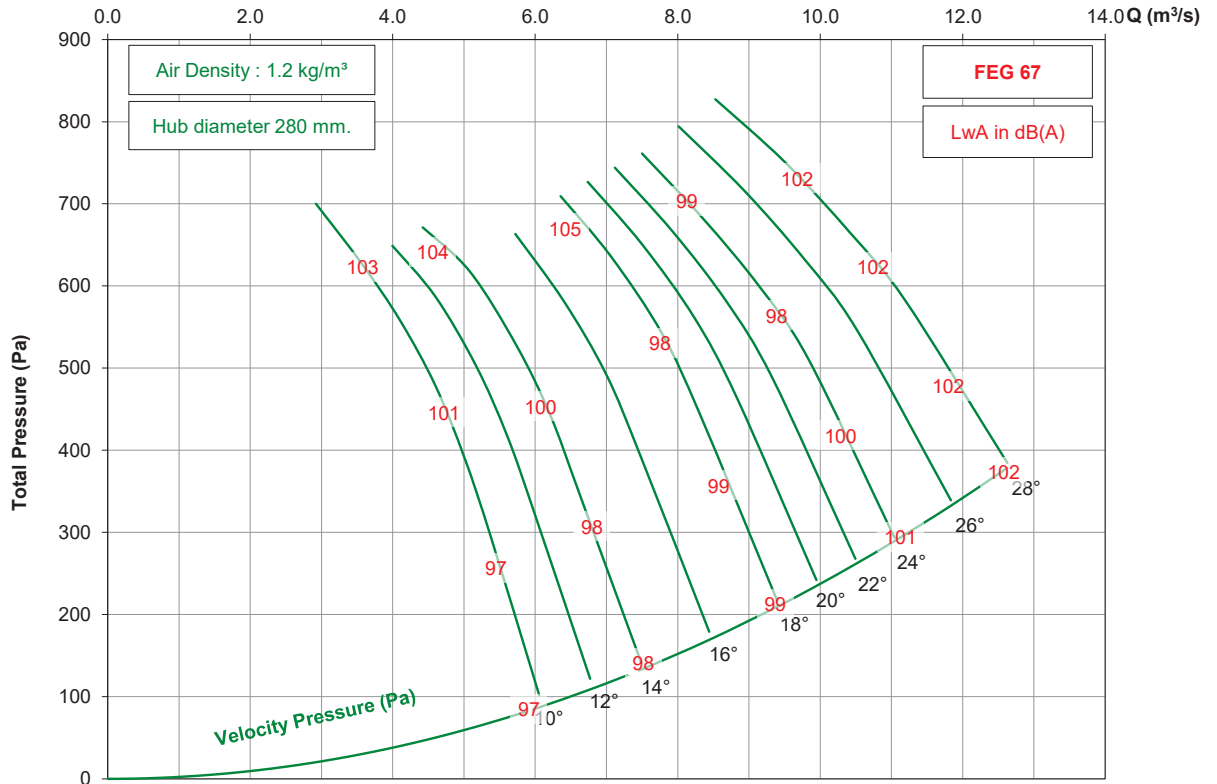

- Performance certified is for installation type D - ducted inlet, ducted outlet. Performance ratings do not include the effects of appurtenances (accessories).  
 - The A-weighted sound ratings shown have been calculated per AMCA International Standard 301. Values shown are for inlet Lwi(A) sound power levels for installation type D - ducted inlet, ducted outlet. Ratings include the effects of duct end correction.

T  
D  
A  
S  
e  
r  
i  
e  
s

# TDA800 / 12AA / 12-12 (280)

1150 rpm - 60 Hz

KRUGER

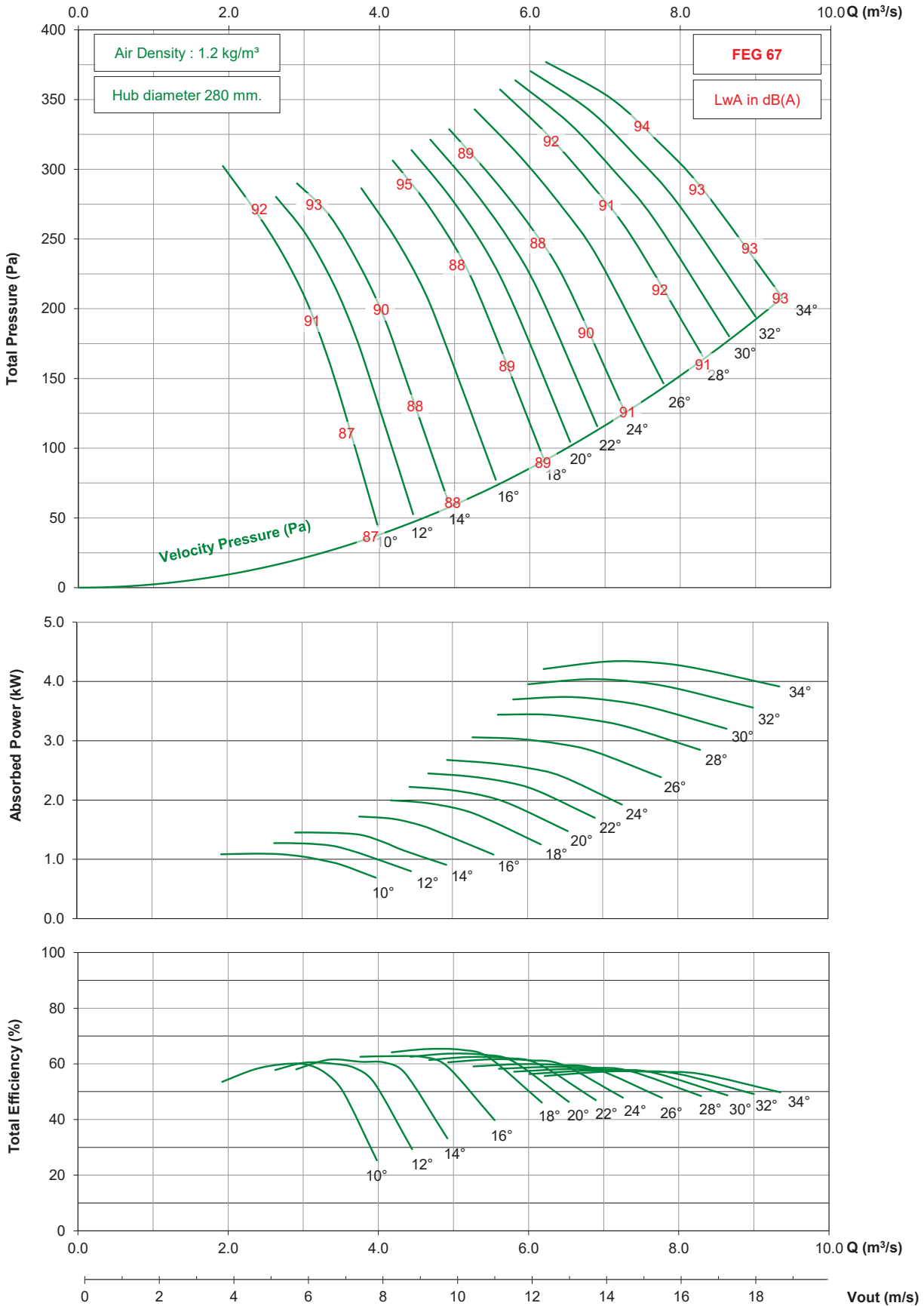

- Performance certified is for installation type D - ducted inlet, ducted outlet. Performance ratings do not include the effects of appurtenances (accessories).  
 - The A-weighted sound ratings shown have been calculated per AMCA International Standard 301. Values shown are for inlet Lw(A) sound power levels for installation type D - ducted inlet, ducted outlet. Ratings include the effects of duct end correction.

TDA Series

# TDA800 / 12AA / 12-12 (280)

875 rpm - 60 Hz

KRUGER

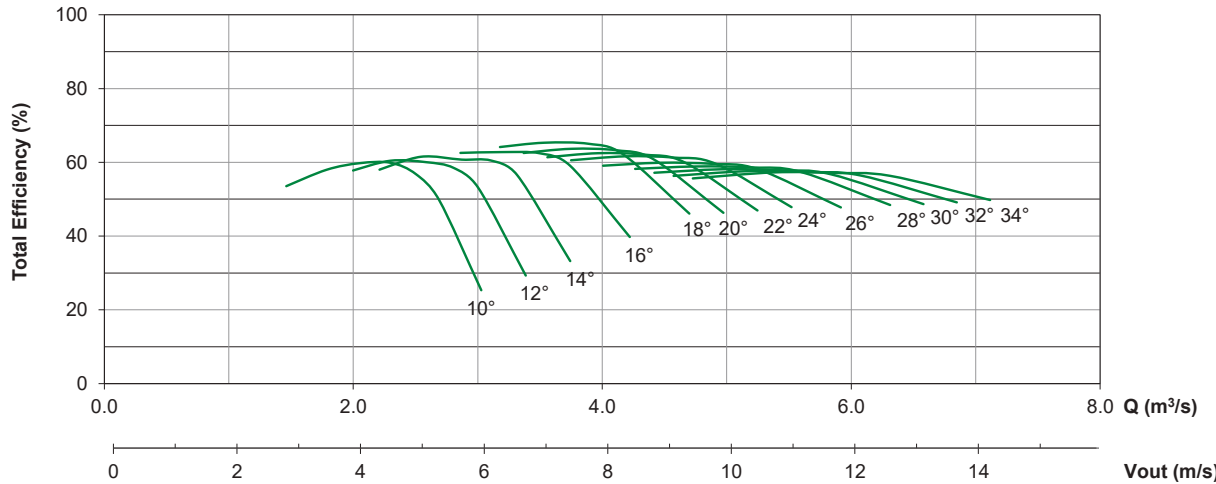
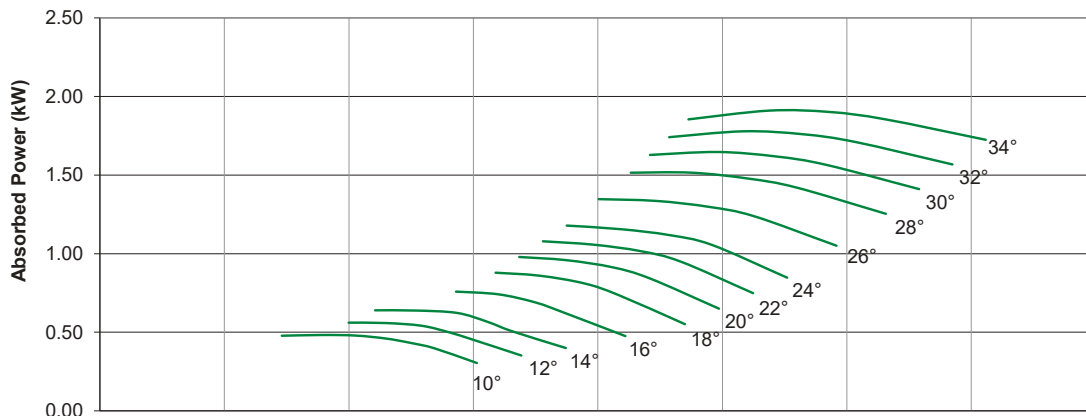
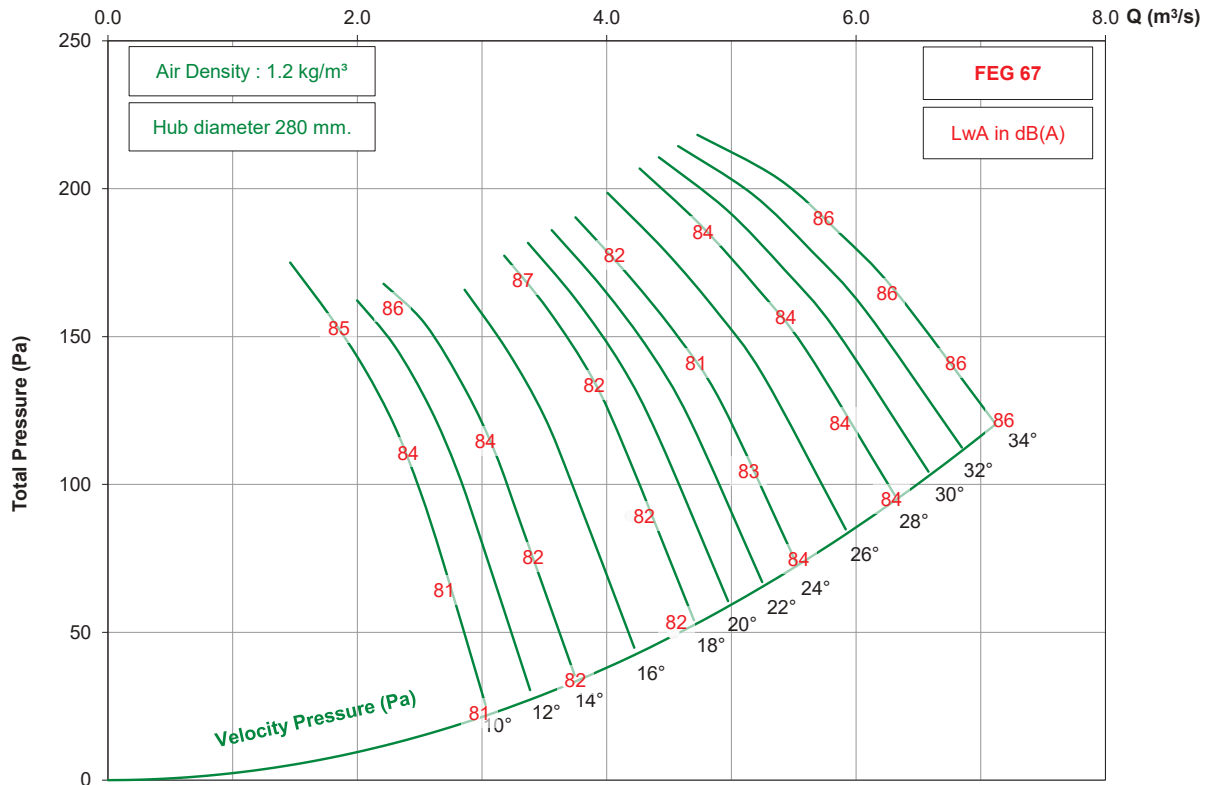

- Performance certified is for installation type D - ducted inlet, ducted outlet. Performance ratings do not include the effects of appurtenances (accessories).  
 - The A-weighted sound ratings shown have been calculated per AMCA International Standard 301. Values shown are for inlet Lw(A) sound power levels for installation type D - ducted inlet, ducted outlet. Ratings include the effects of duct end correction.

T  
D  
A  
  
S  
e  
r  
i  
e  
s



# TDA900 / 14AA / 9-9 (200)

950 rpm - 50 Hz

KRUGER

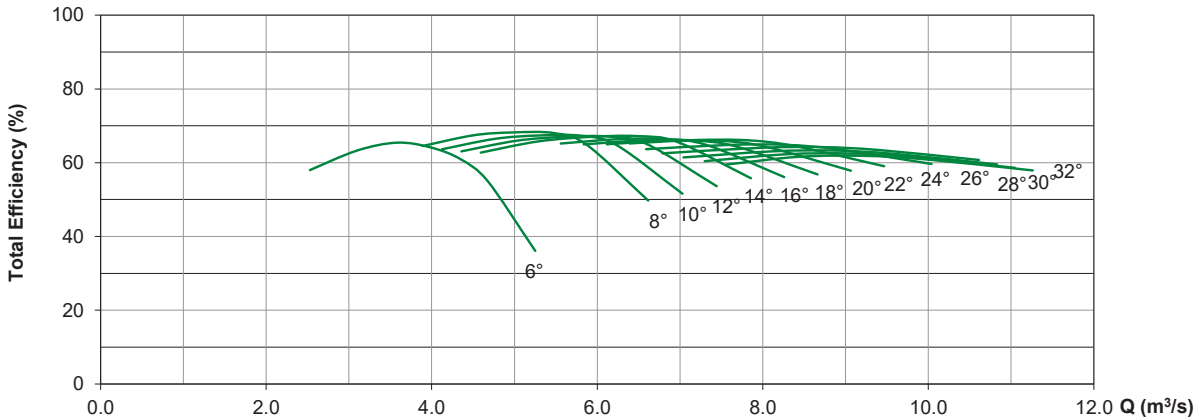
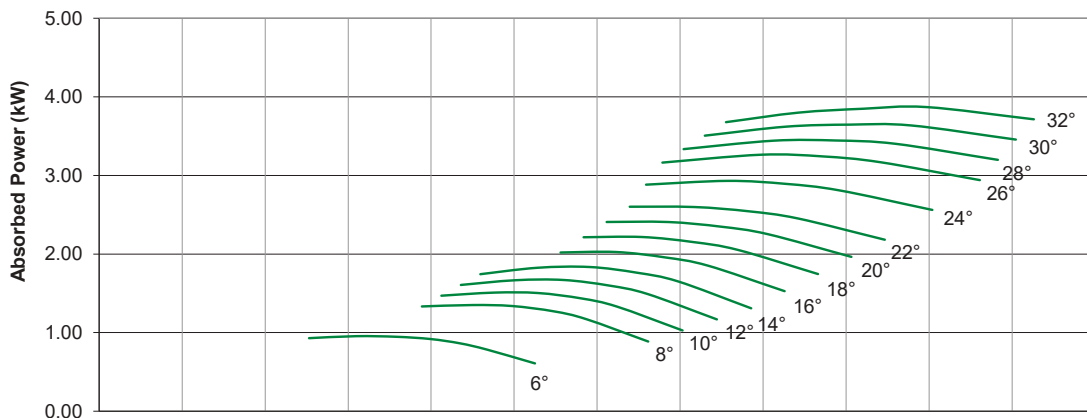
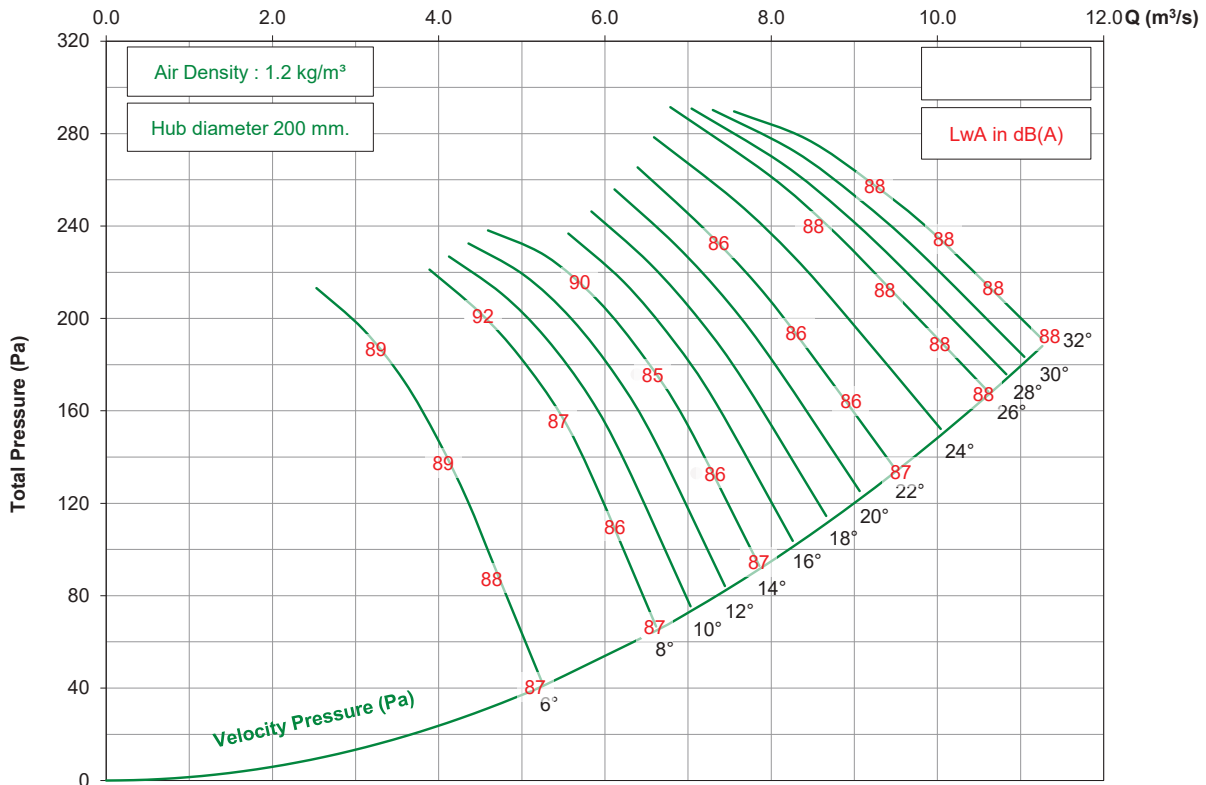

0 2 4 6 8 10 12 14 16 18 **Vout (m/s)**

- Performance certified for installation type D - ducted inlet, ducted outlet. Performance ratings do not include the effects of appurtenances (accessories).  
 - The A-weighted sound ratings shown have been calculated per AMCA International Standard 301. Values shown are for inlet Lwi(A) sound power levels for installation type D - ducted inlet, ducted outlet. Ratings include the effects of duct end correction.

T  
D  
A  
  
S  
e  
r  
i  
e  
s

# TDA900 / 14AA / 9-9 (200)

725 rpm - 50 Hz

KRUGER

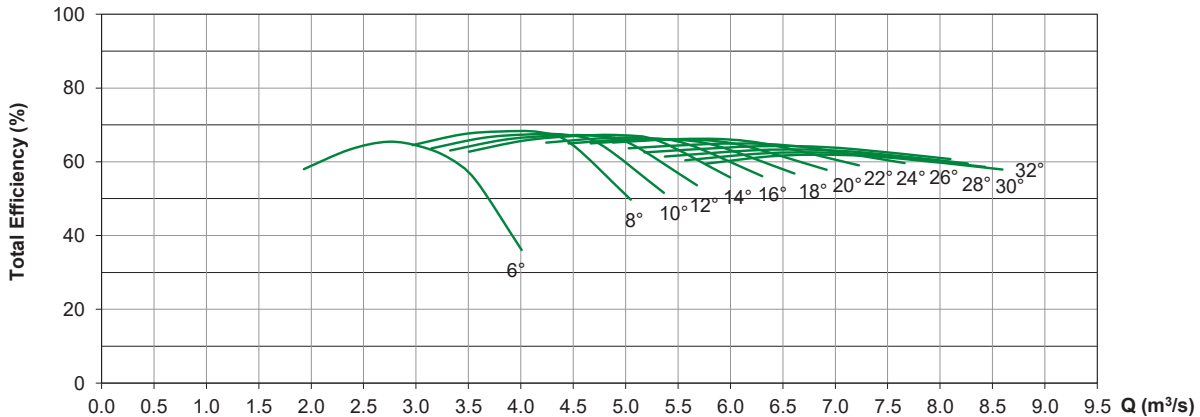
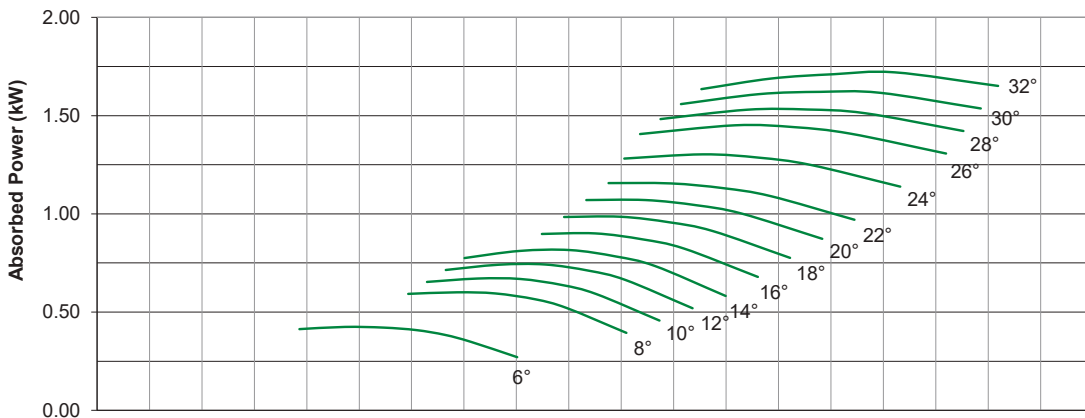
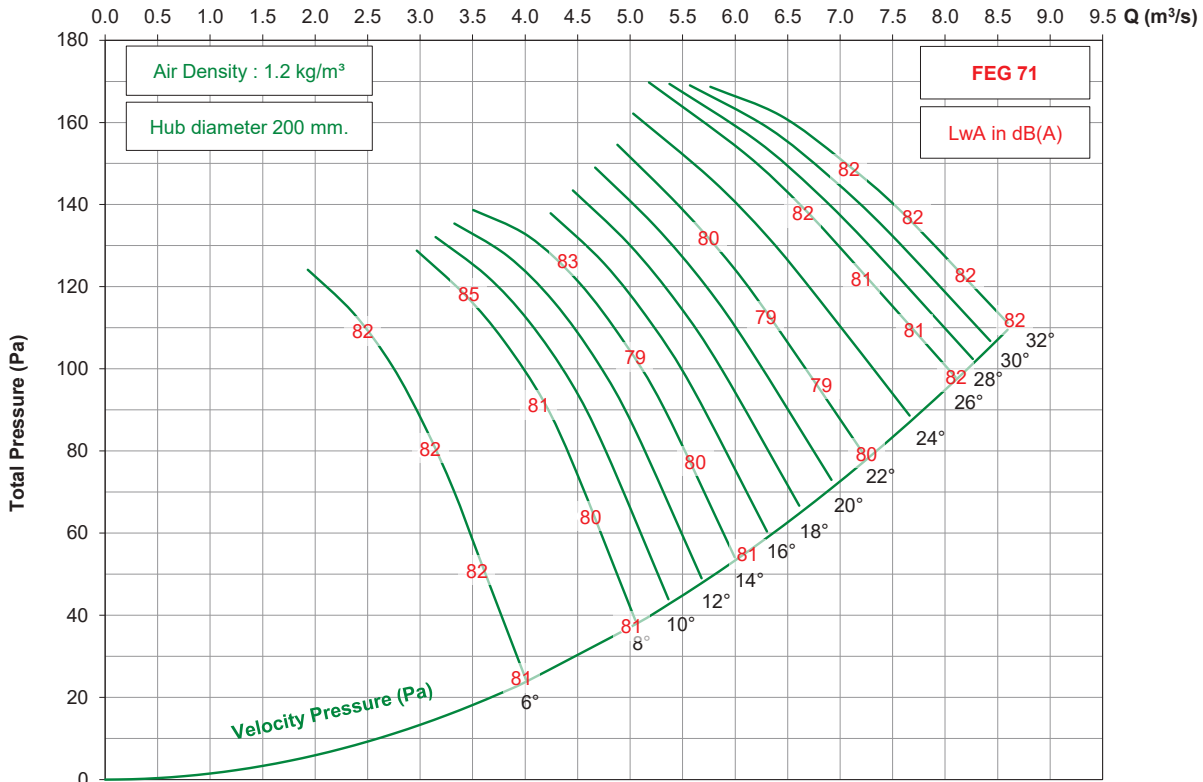

0 0.5 1.0 1.5 2.0 2.5 3.0 3.5 4.0 4.5 5.0 5.5 6.0 6.5 7.0 7.5 8.0 8.5 9.0 9.5 Q (m³/s)

0 2 4 6 8 10 12 Vout (m/s)

- Performance certified for installation type D - ducted inlet, ducted outlet. Performance ratings do not include the effects of appurtenances (accessories).

- The A-weighted sound ratings shown have been calculated per AMCA International Standard 301. Values shown are for inlet Lwi(A) sound power levels for installation type D - ducted inlet, ducted outlet. Ratings include the effects of duct end correction.

TDA Series



# TDA900 / 14AA / 9-9 (200)

1150 rpm - 60 Hz

KRUGER

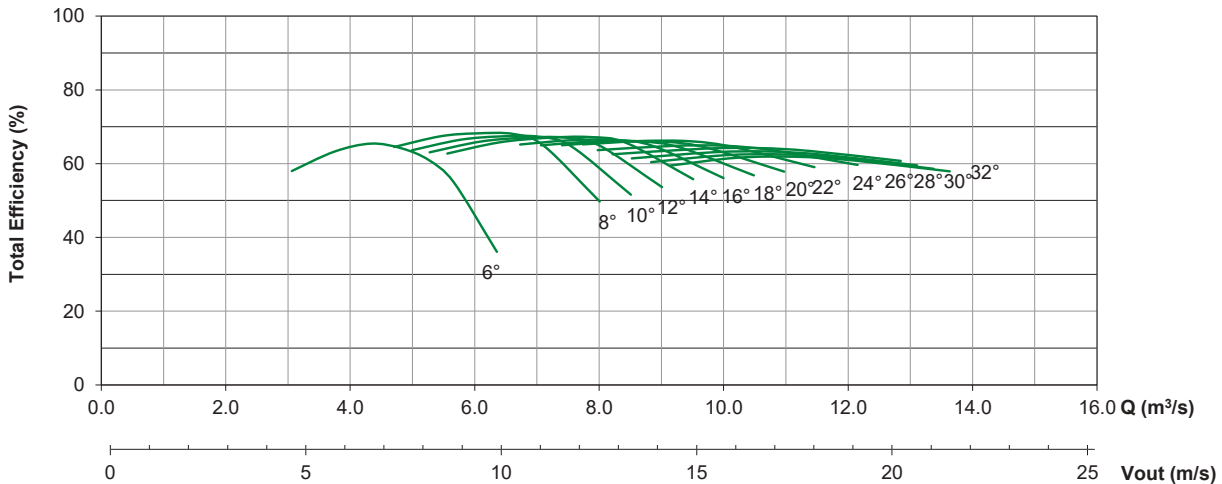
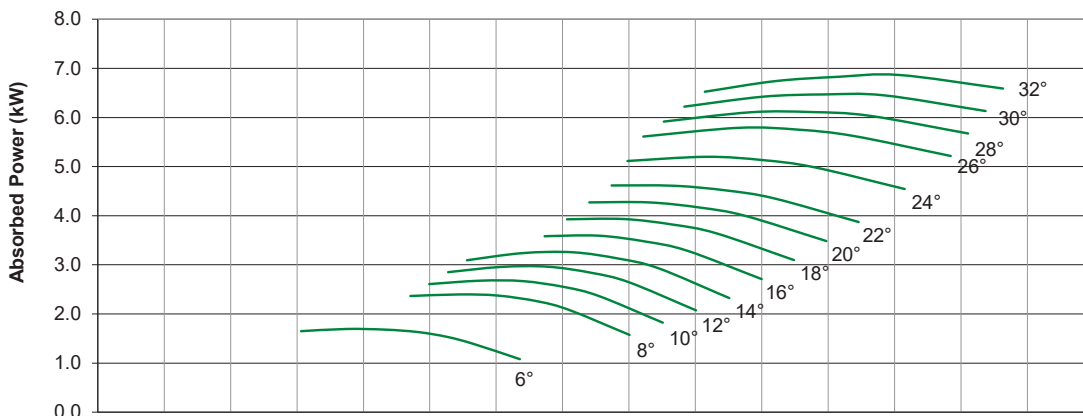
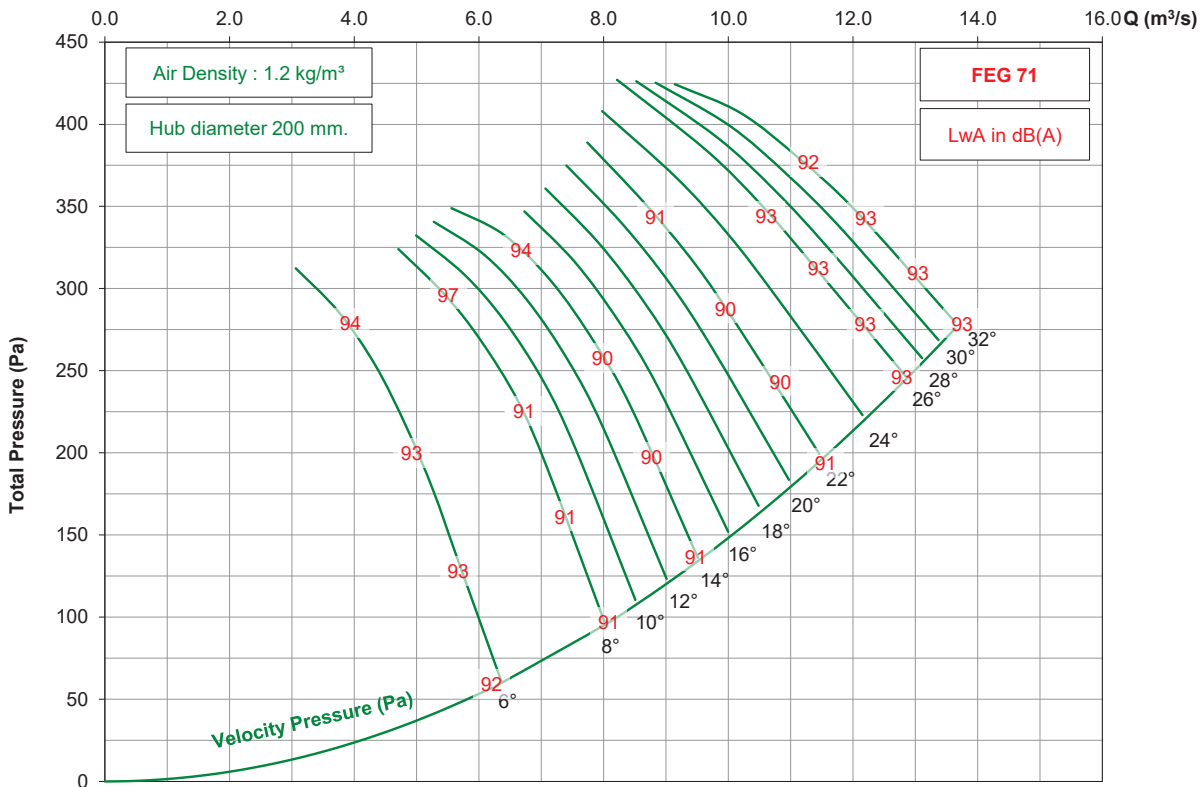

- Performance certified is for installation type D - ducted inlet, ducted outlet. Performance ratings do not include the effects of appurtenances (accessories).  
 - The A-weighted sound ratings shown have been calculated per AMCA International Standard 301. Values shown are for inlet Lw(A) sound power levels for installation type D - ducted inlet, ducted outlet. Ratings include the effects of duct end correction.

# TDA900 / 14AA / 9-9 (200)

875 rpm - 60 Hz

KRUGER

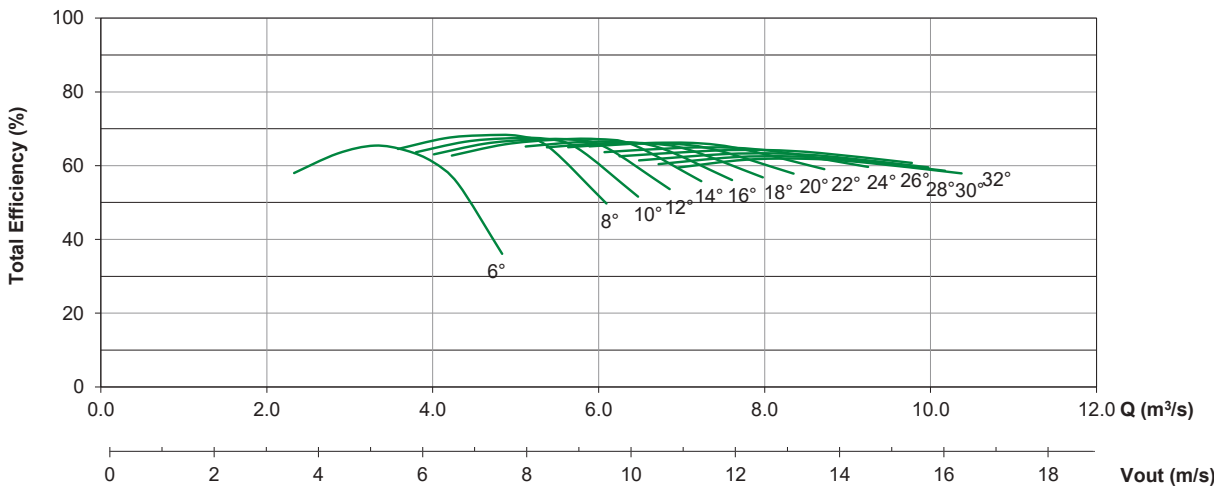
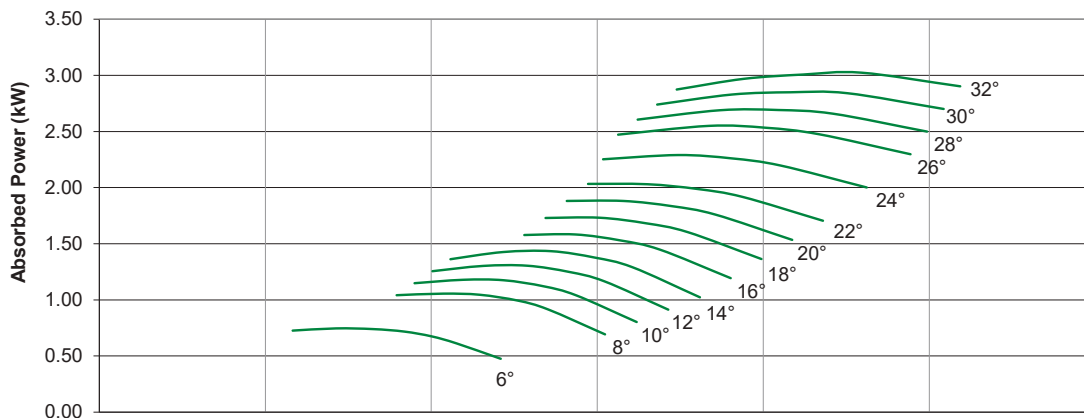
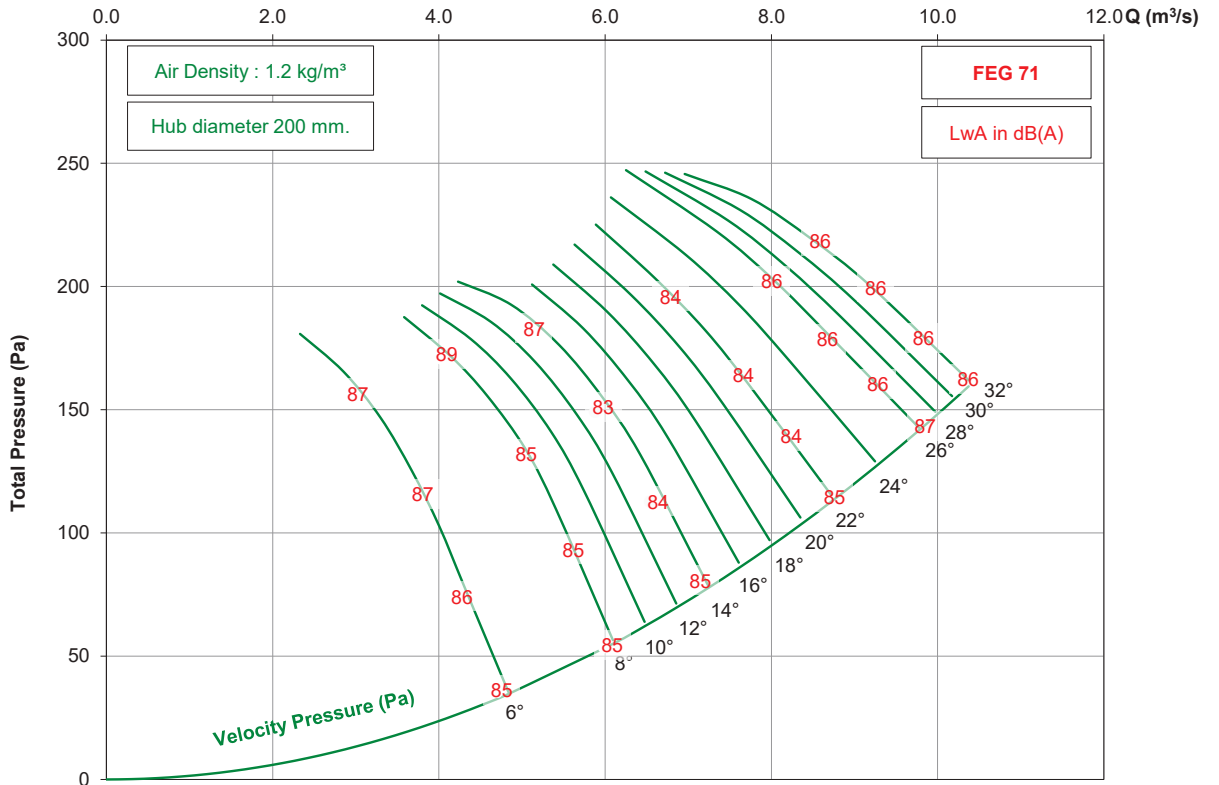

- Performance certified is for installation type D - ducted inlet, ducted outlet. Performance ratings do not include the effects of appurtenances (accessories).  
 - The A-weighted sound ratings shown have been calculated per AMCA International Standard 301. Values shown are for inlet Lw(A) sound power levels for installation type D - ducted inlet, ducted outlet. Ratings include the effects of duct end correction.

T  
D  
A  
  
S  
e  
r  
i  
e  
s

# TDA1000 / 14AA / 9-9 (200)

1450 rpm - 50 Hz

KRUGER

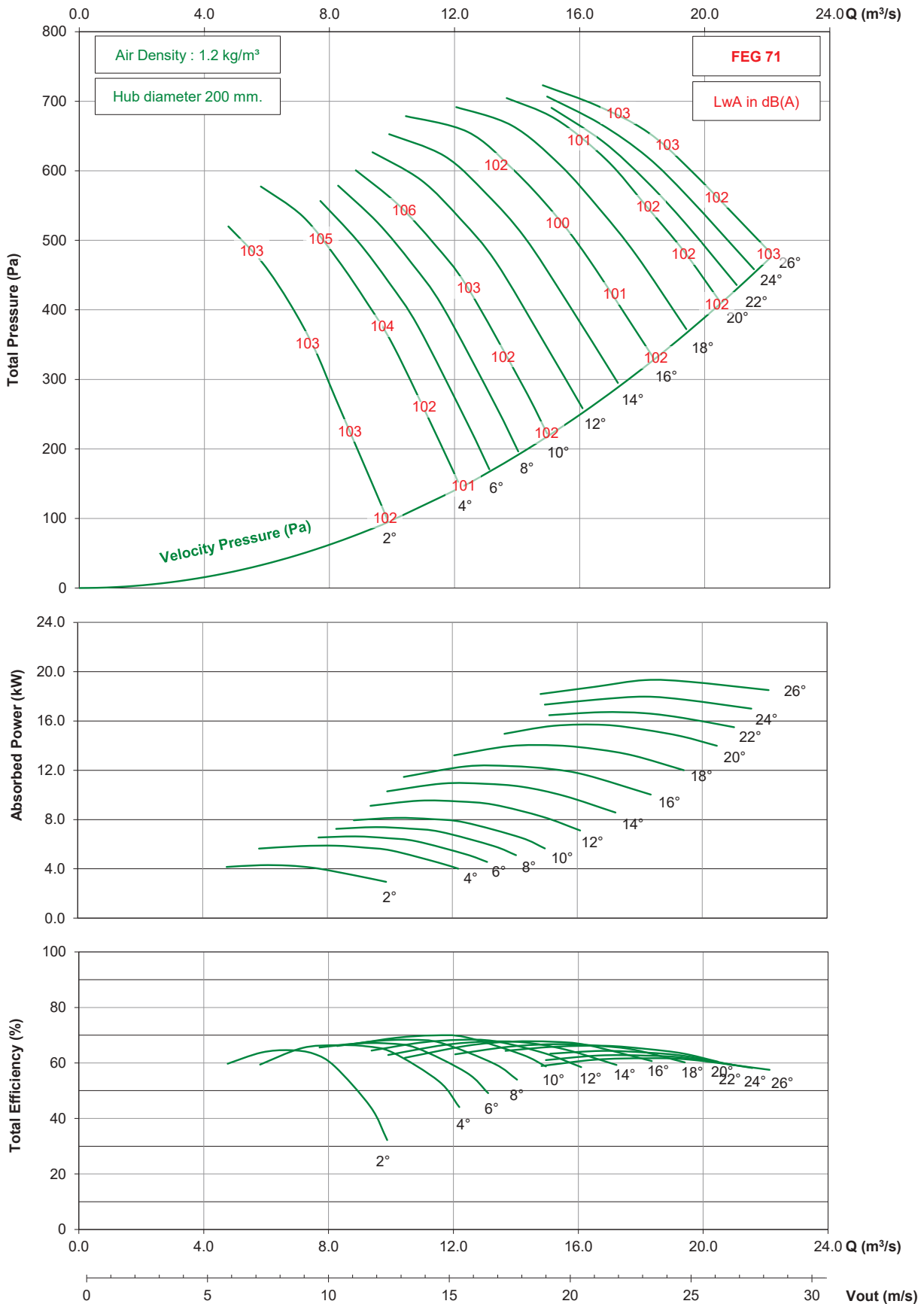

- Performance certified for installation type D - ducted inlet, ducted outlet. Performance ratings do not include the effects of appurtenances (accessories).  
 - The A-weighted sound ratings shown have been calculated per AMCA International Standard 301. Values shown are for inlet Lwi(A) sound power levels for installation type D - ducted inlet, ducted outlet. Ratings include the effects of duct end correction.

T  
D  
A  
  
S  
e  
r  
i  
e  
s

# TDA1000 / 14AA / 9-9 (200)

950 rpm - 50 Hz

KRUGER

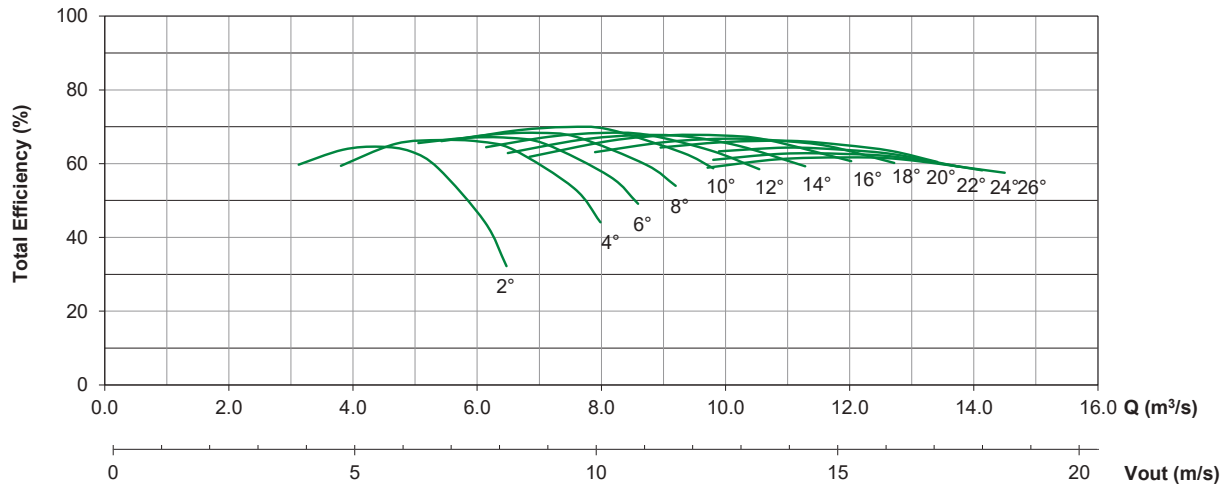
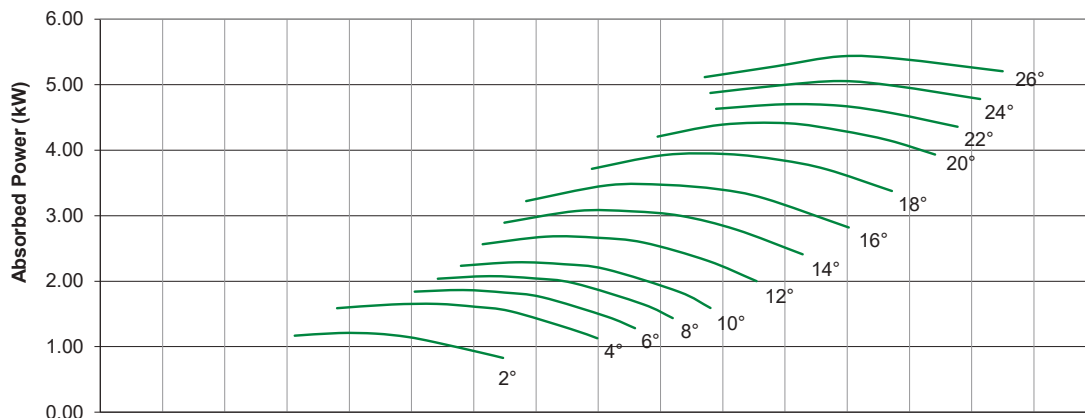
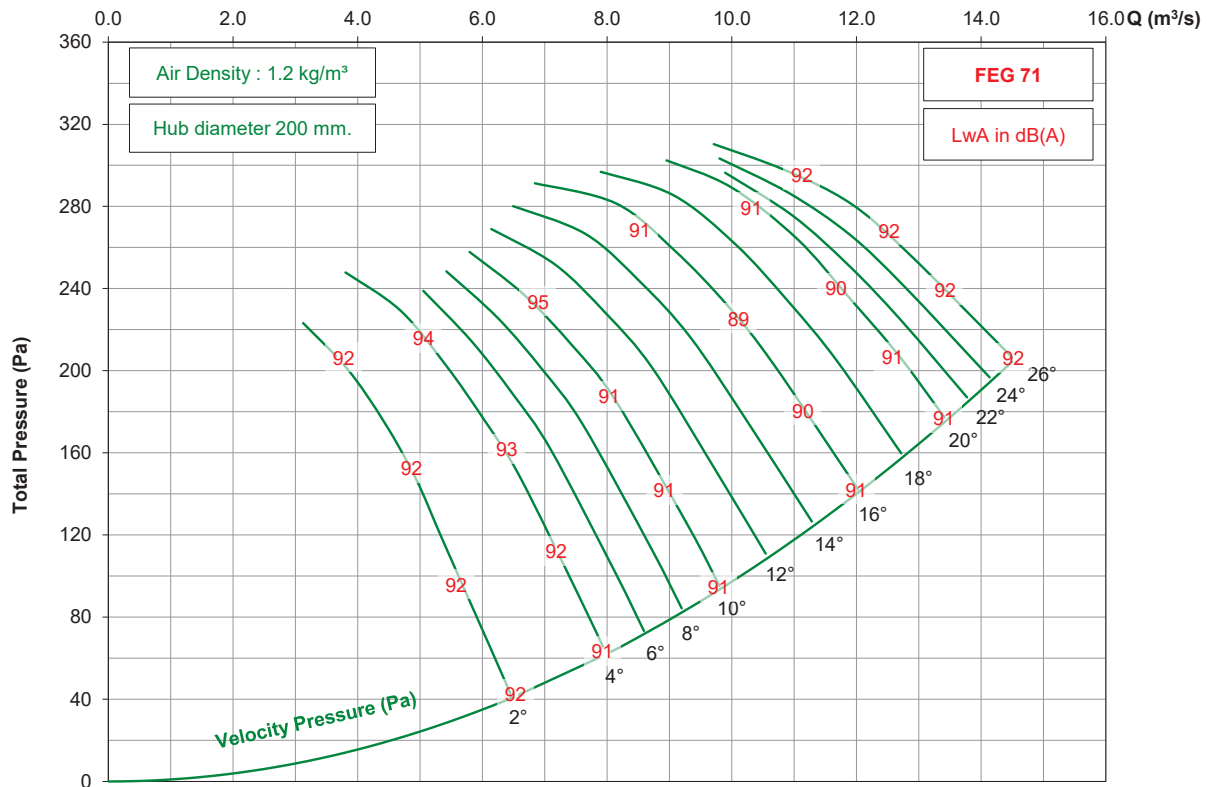

- Performance certified is for installation type D - ducted inlet, ducted outlet. Performance ratings do not include the effects of appurtenances (accessories).  
 - The A-weighted sound ratings shown have been calculated per AMCA International Standard 301. Values shown are for inlet Lwi(A) sound power levels for installation type D - ducted inlet, ducted outlet. Ratings include the effects of duct end correction.

# TDA1000 / 14AA / 9-9 (200)

725 rpm - 50 Hz

KRUGER

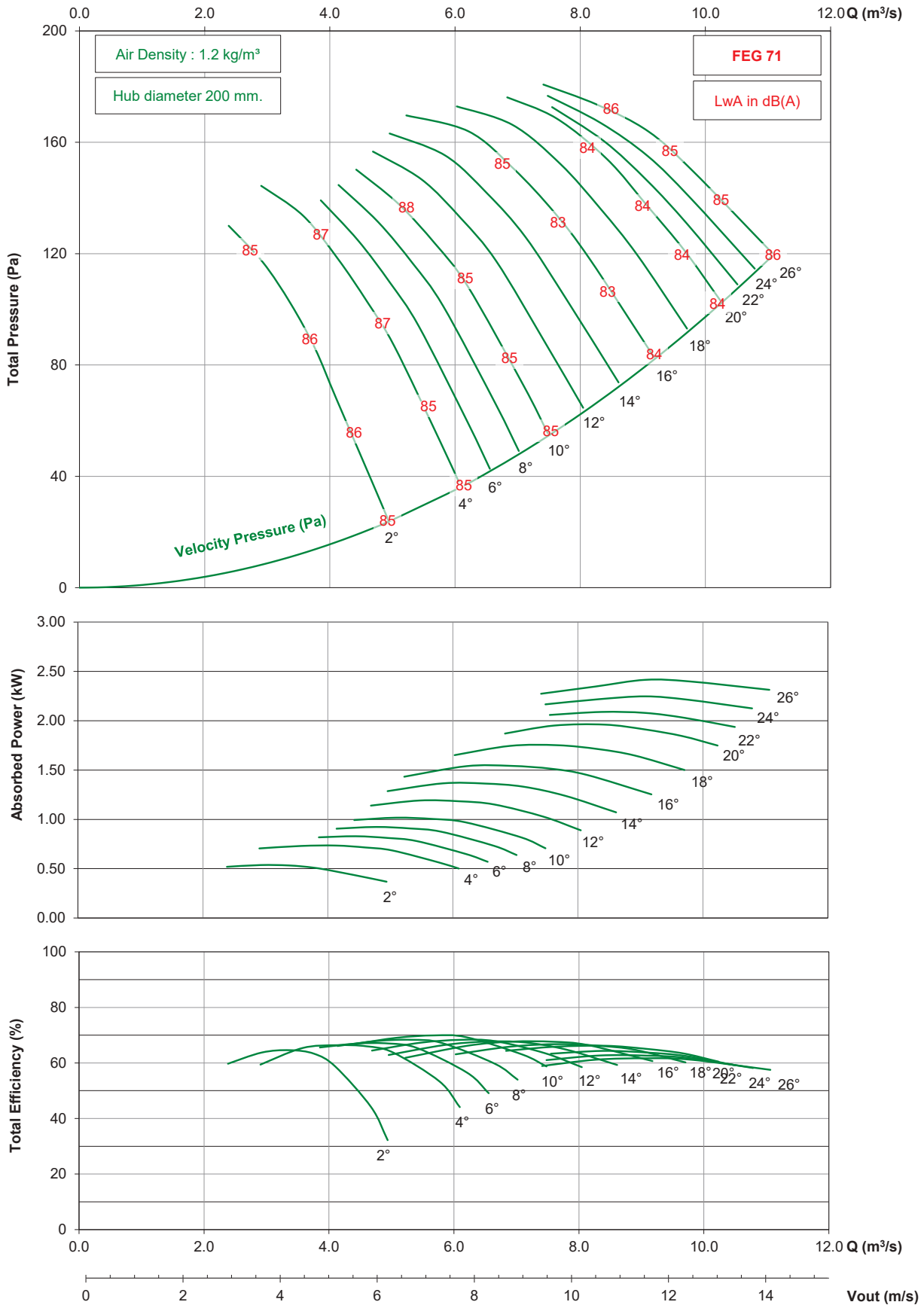

- Performance certified is for installation type D - ducted inlet, ducted outlet. Performance ratings do not include the effects of appurtenances (accessories).  
 - The A-weighted sound ratings shown have been calculated per AMCA International Standard 301. Values shown are for inlet Lwi(A) sound power levels for installation type D - ducted inlet, ducted outlet. Ratings include the effects of duct end correction.

# TDA1000 / 14AA / 9-9 (200)

1750 rpm - 60 Hz

KRUGER

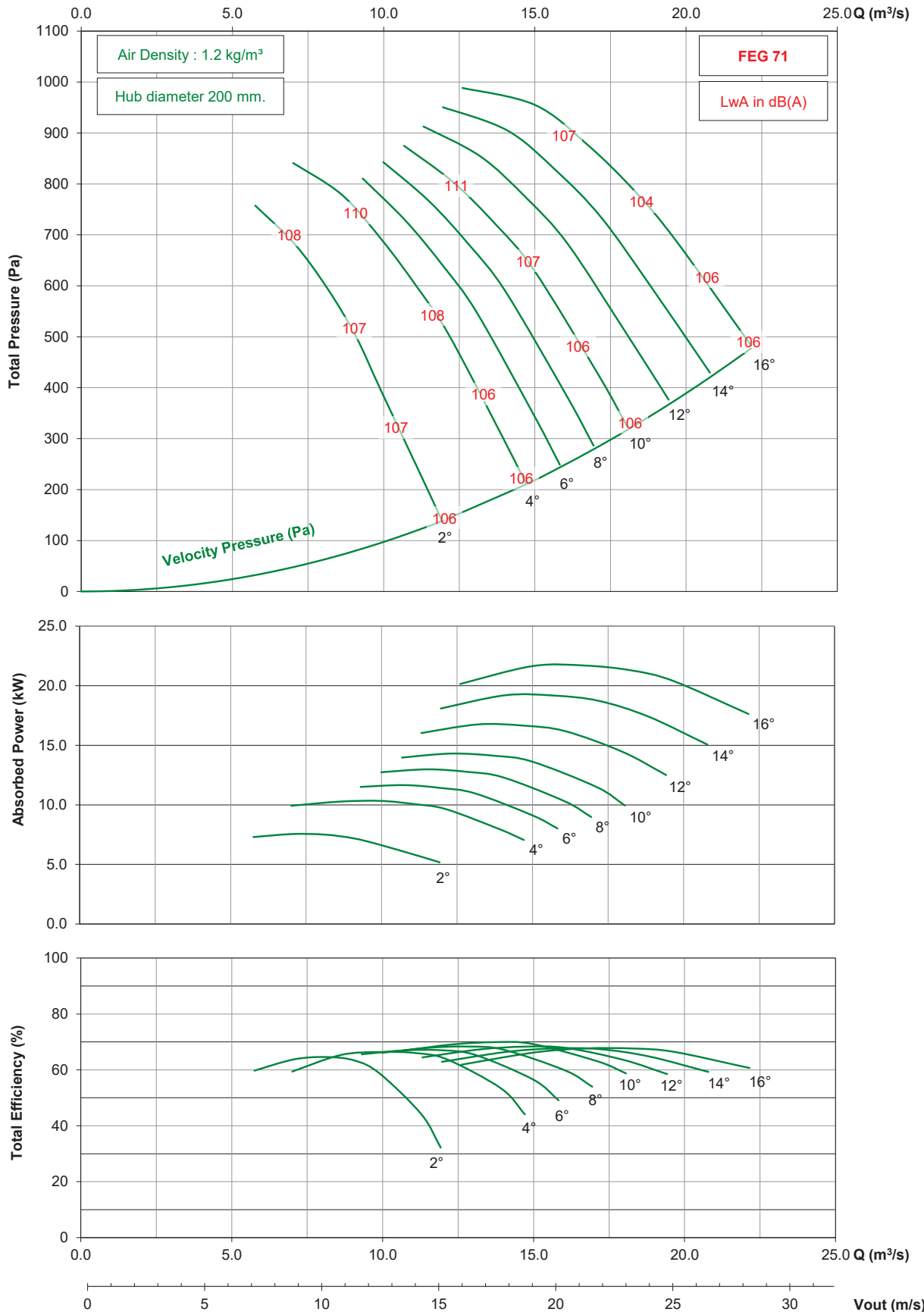

- Performance certified is for installation type D - ducted inlet, ducted outlet. Performance ratings do not include the effects of appurtenances (accessories).

- The A-weighted sound ratings shown have been calculated per AMCA International Standard 301. Values shown are for inlet Lwi(A) sound power levels for installation type D - ducted inlet, ducted outlet. Ratings include the effects of duct end correction.

# TDA1000 / 14AA / 9-9 (200)

1150 rpm - 60 Hz

KRUGER

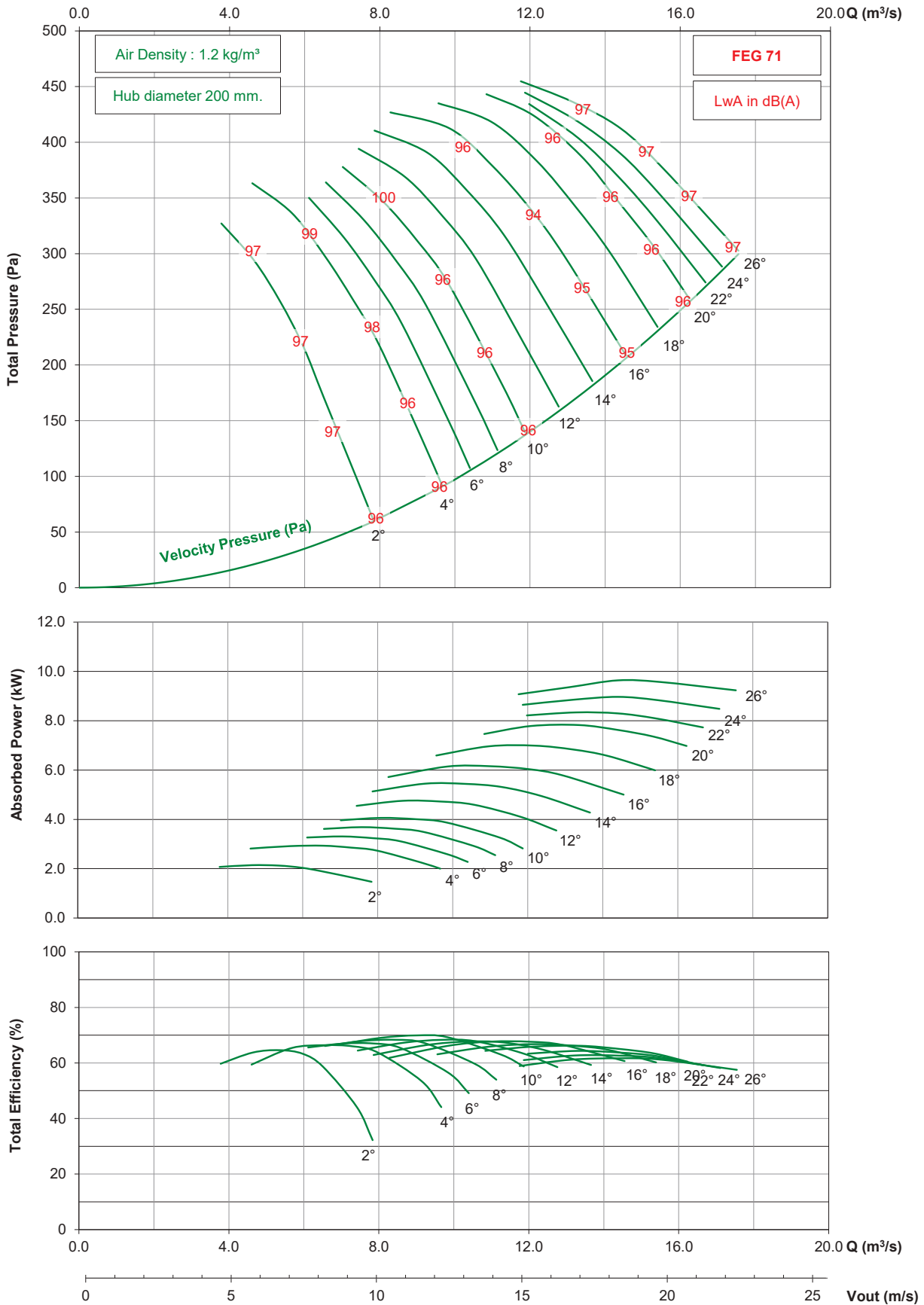

- Performance certified is for installation type D - ducted inlet, ducted outlet. Performance ratings do not include the effects of appurtenances (accessories).  
 - The A-weighted sound ratings shown have been calculated per AMCA International Standard 301. Values shown are for inlet Lwi(A) sound power levels for installation type D - ducted inlet, ducted outlet. Ratings include the effects of duct end correction.

TDA Series

# TDA1000 / 14AA / 9-9 (200)

875 rpm - 60 Hz

KRUGER

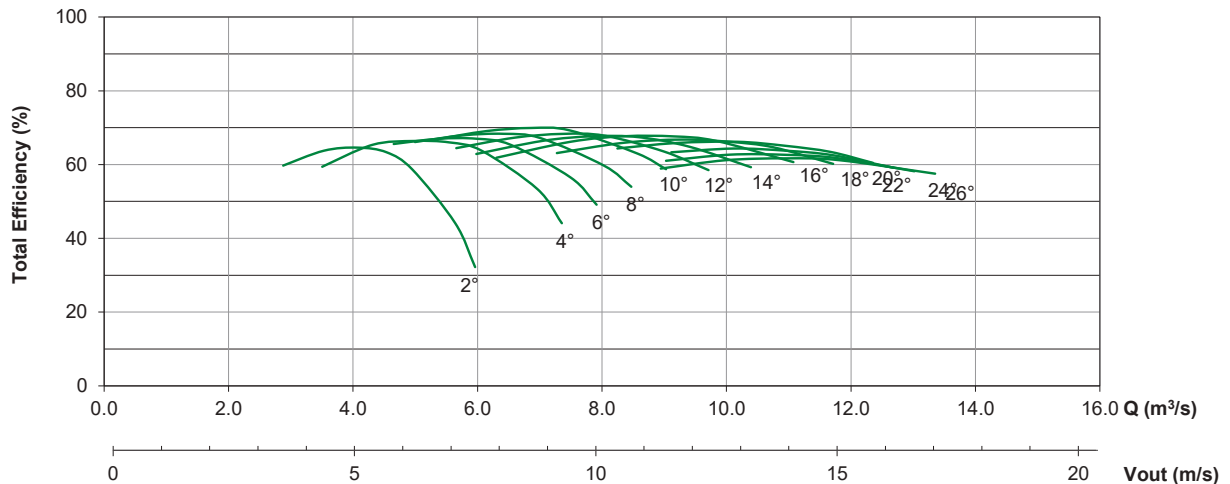
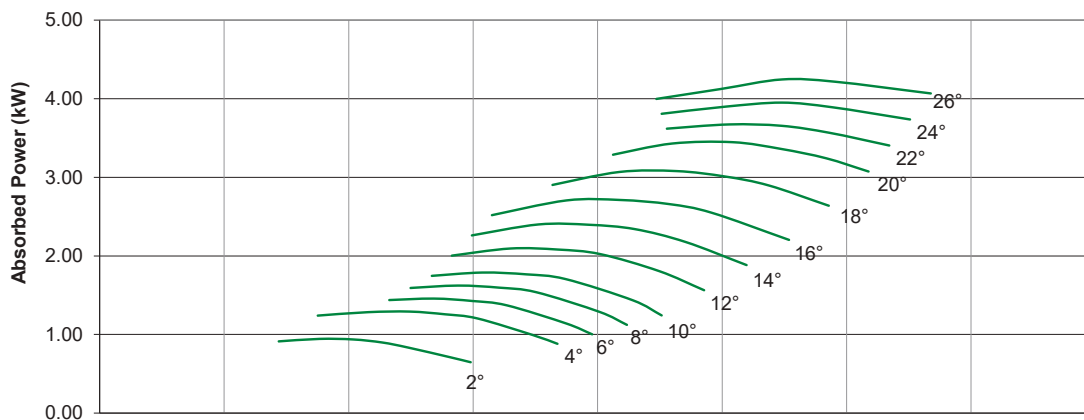
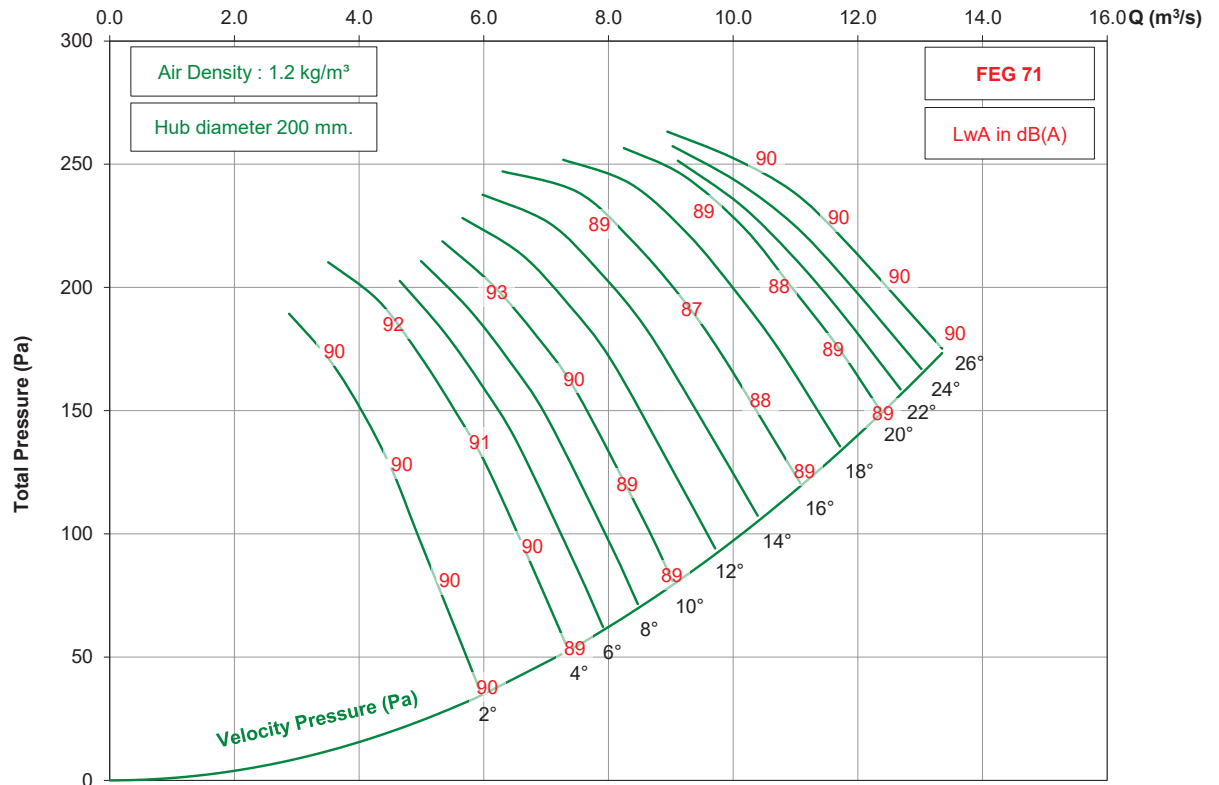

- Performance certified is for installation type D - ducted inlet, ducted outlet. Performance ratings do not include the effects of appurtenances (accessories).  
 - The A-weighted sound ratings shown have been calculated per AMCA International Standard 301. Values shown are for inlet Lwi(A) sound power levels for installation type D - ducted inlet, ducted outlet. Ratings include the effects of duct end correction.

T  
D  
A  
  
S  
e  
r  
i  
e  
s

# TDA1120/ 14AA / 9-12 (280)

1450 rpm - 50 Hz

KRUGER

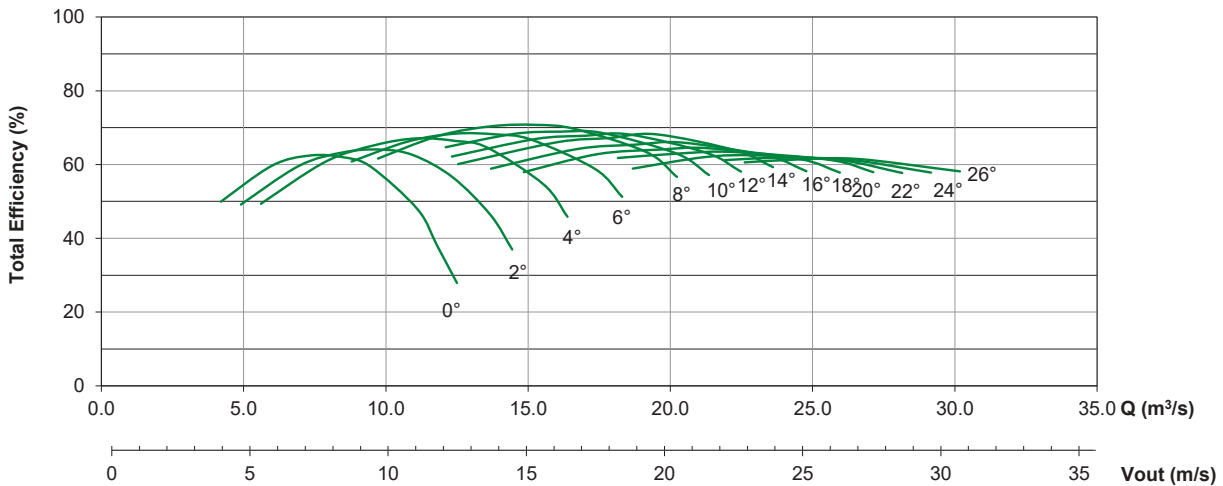
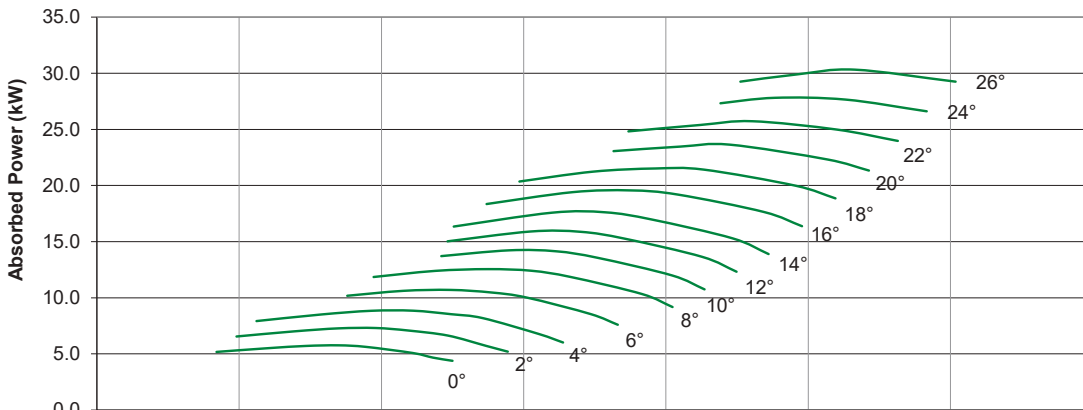
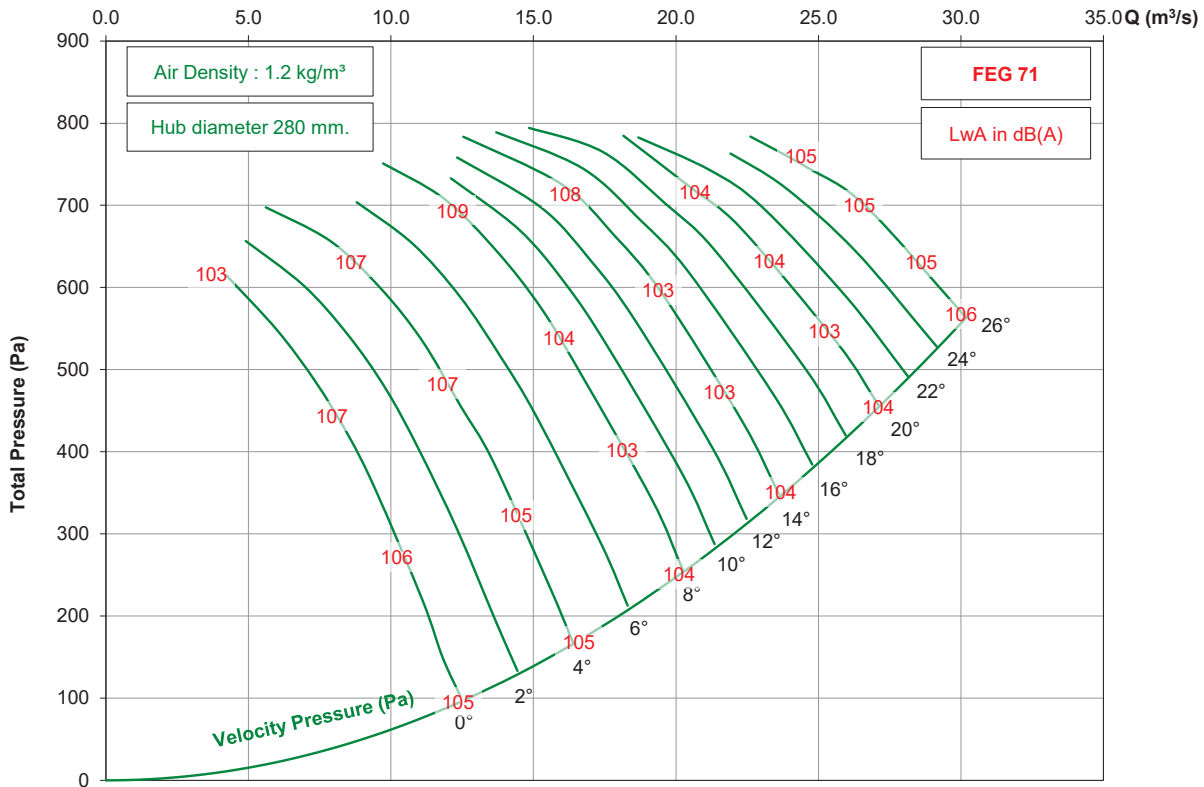

- Performance certified for installation type D - ducted inlet, ducted outlet. Performance ratings do not include the effects of appurtenances (accessories).  
 - The A-weighted sound ratings shown have been calculated per AMCA International Standard 301. Values shown are for inlet Lw(A) sound power levels for installation type D - ducted inlet, ducted outlet. Ratings include the effects of duct end correction.

TDA Series

# TDA1120/ 14AA / 9-12 (280)

950 rpm - 50 Hz

KRUGER

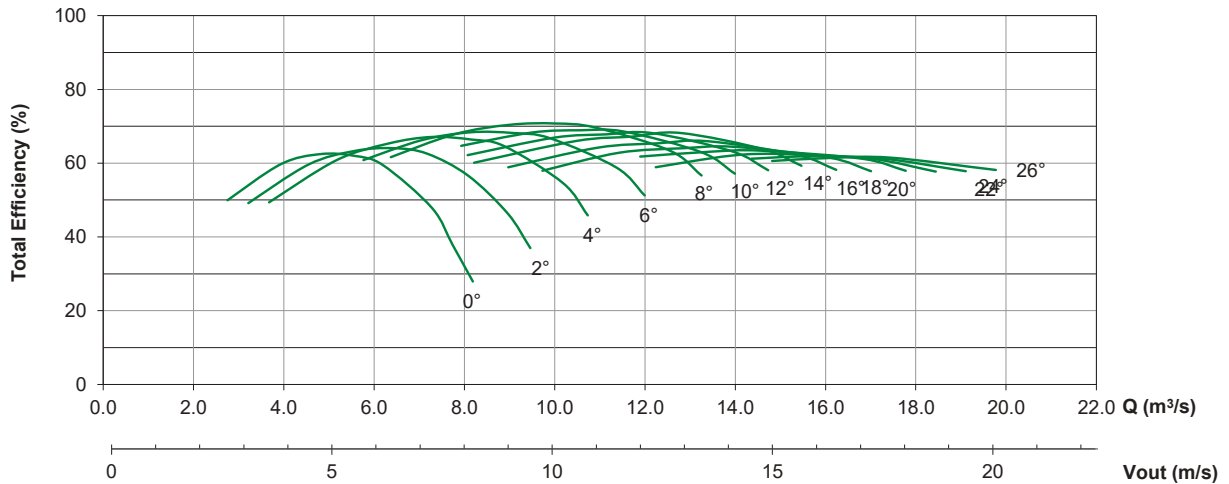
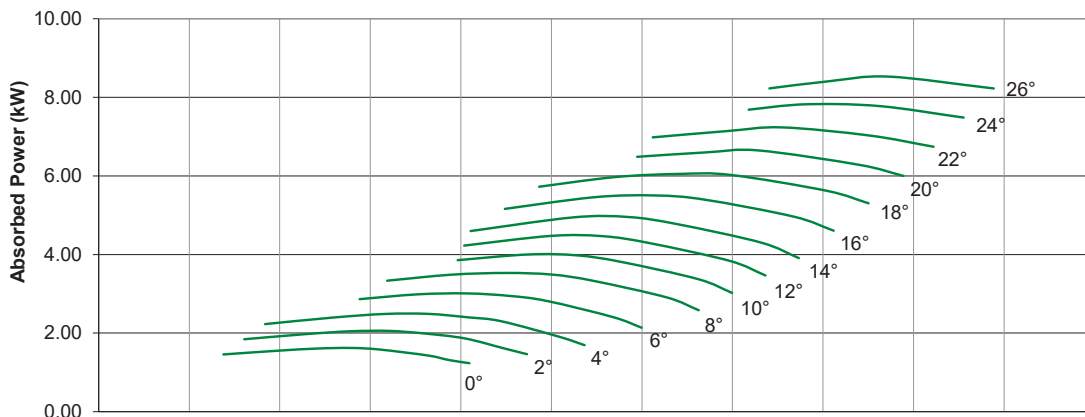
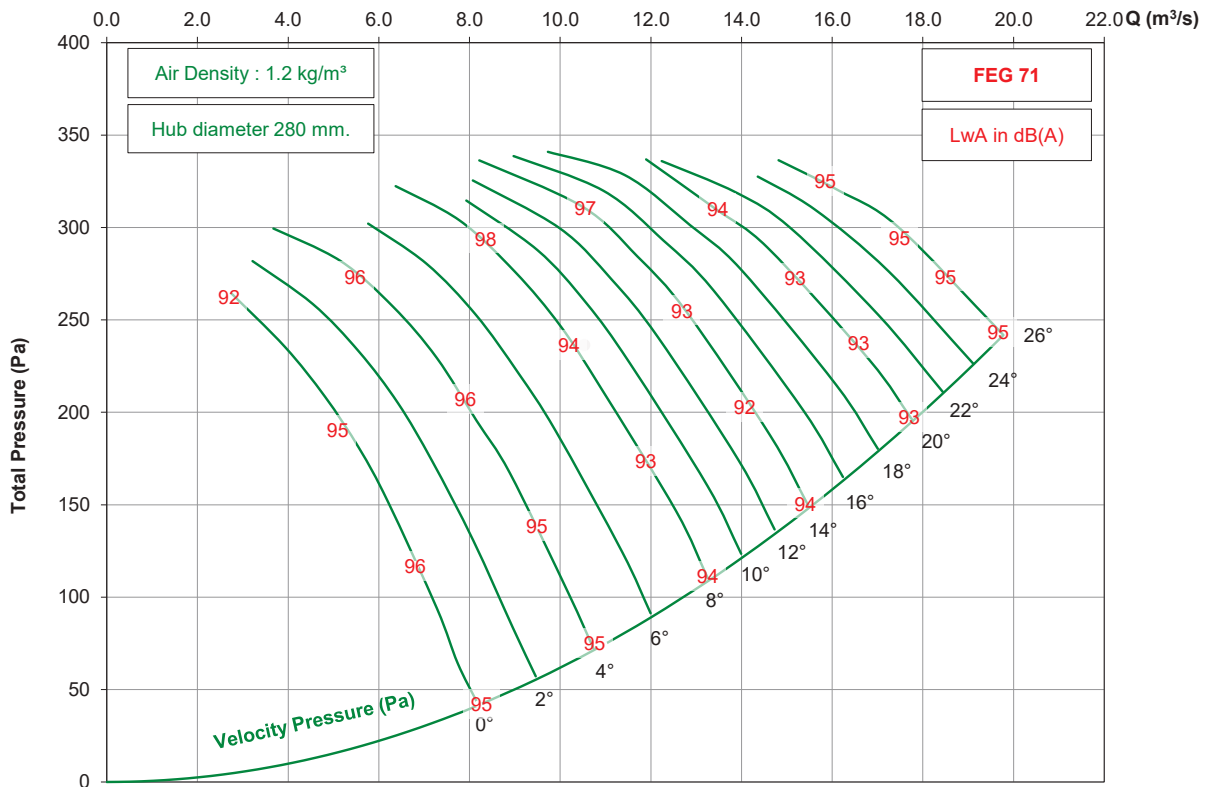

- Performance certified is for installation type D - ducted inlet, ducted outlet. Performance ratings do not include the effects of appurtenances (accessories).  
 - The A-weighted sound ratings shown have been calculated per AMCA International Standard 301. Values shown are for inlet Lw(A) sound power levels for installation type D - ducted inlet, ducted outlet. Ratings include the effects of duct end correction.

TDA Series

# TDA1120/ 14AA / 9-12 (280)

725 rpm - 50 Hz

KRUGER

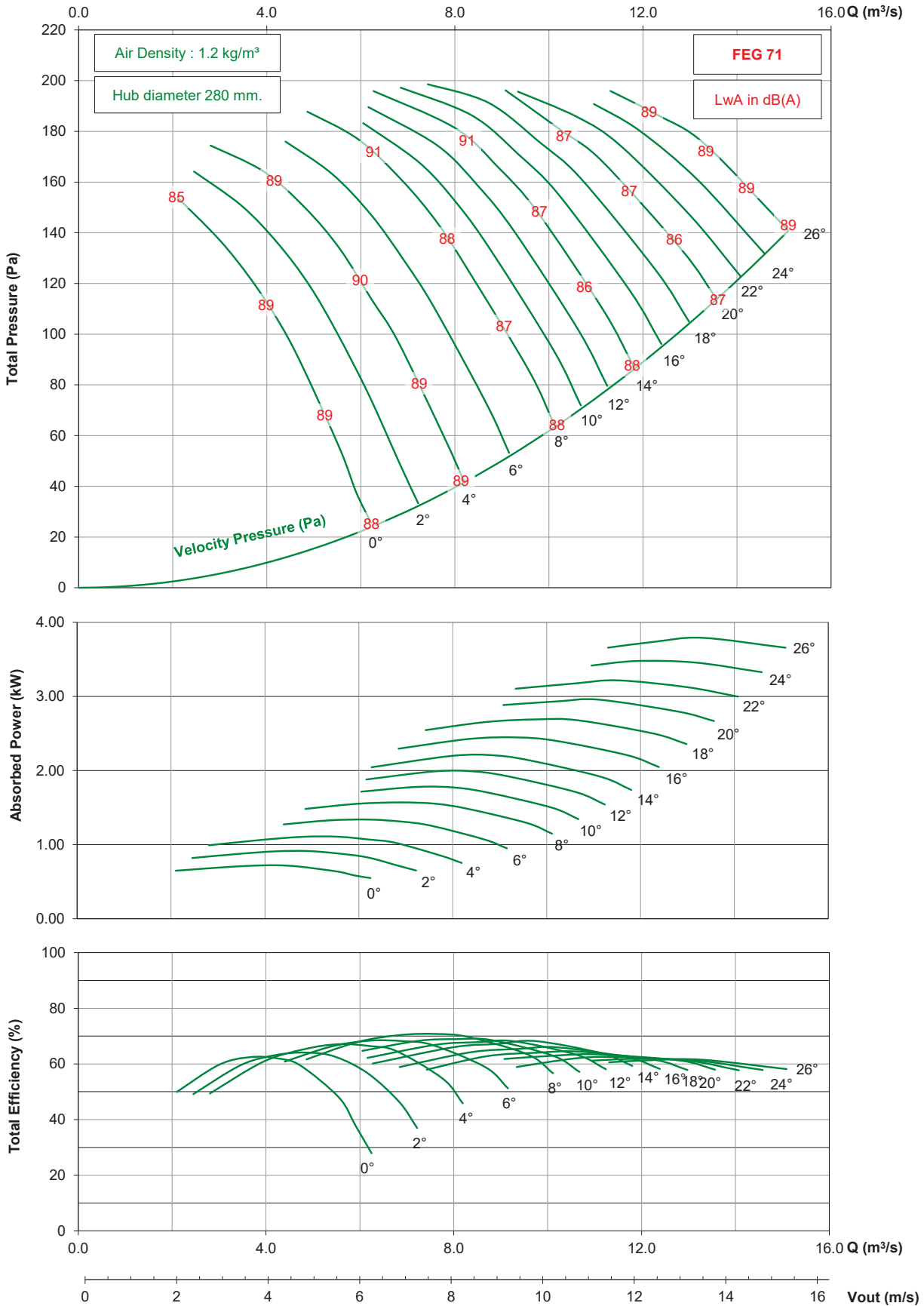

- Performance certified for installation type D - ducted inlet, ducted outlet. Performance ratings do not include the effects of appurtenances (accessories).  
 - The A-weighted sound ratings shown have been calculated per AMCA International Standard 301. Values shown are for inlet Lwi(A) sound power levels for installation type D - ducted inlet, ducted outlet. Ratings include the effects of duct end correction.

# TDA1120/ 14AA / 9-12 (280)

1750 rpm - 60 Hz

KRUGER

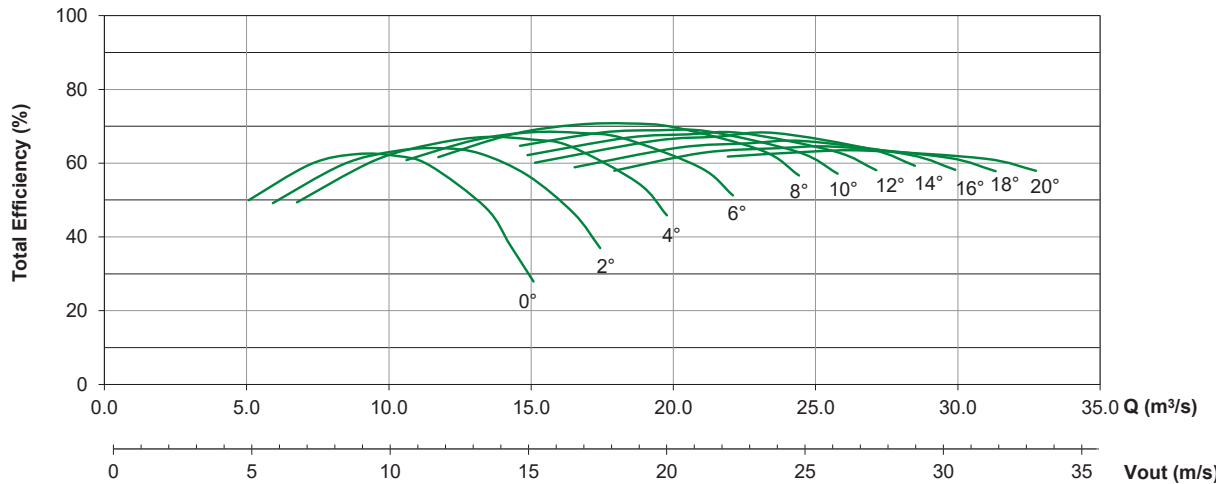
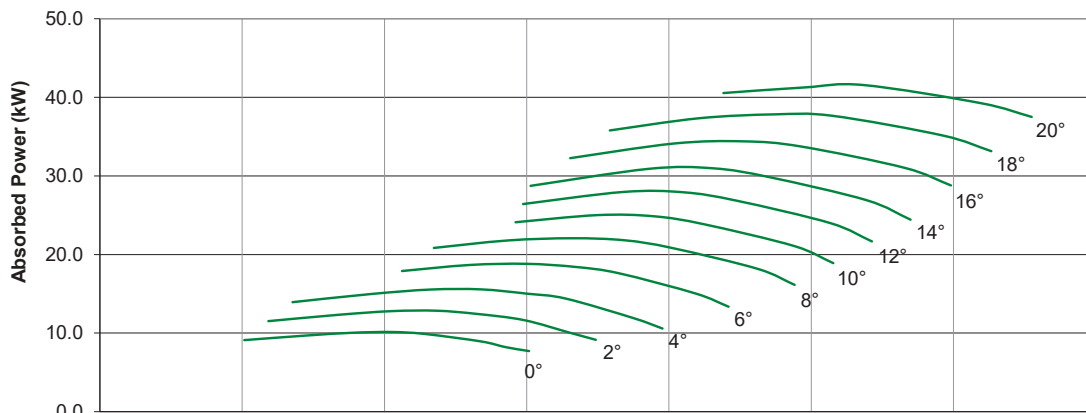
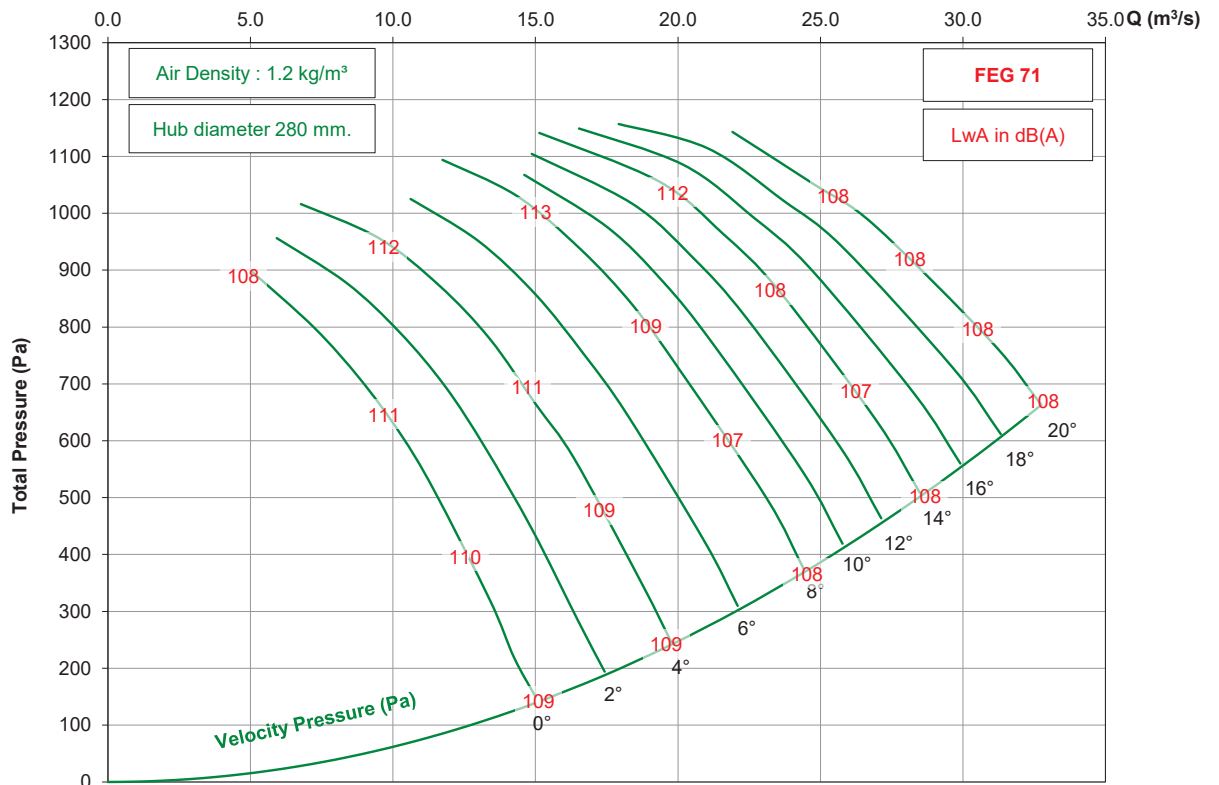

- Performance certified for installation type D - ducted inlet, ducted outlet. Performance ratings do not include the effects of appurtenances (accessories).  
 - The A-weighted sound ratings shown have been calculated per AMCA International Standard 301. Values shown are for inlet Lwi(A) sound power levels for installation type D - ducted inlet, ducted outlet. Ratings include the effects of duct end correction.

T  
D  
A  
  
S  
e  
r  
i  
e  
s

# TDA1120/ 14AA / 9-12 (280)

1150 rpm - 60 Hz

KRUGER

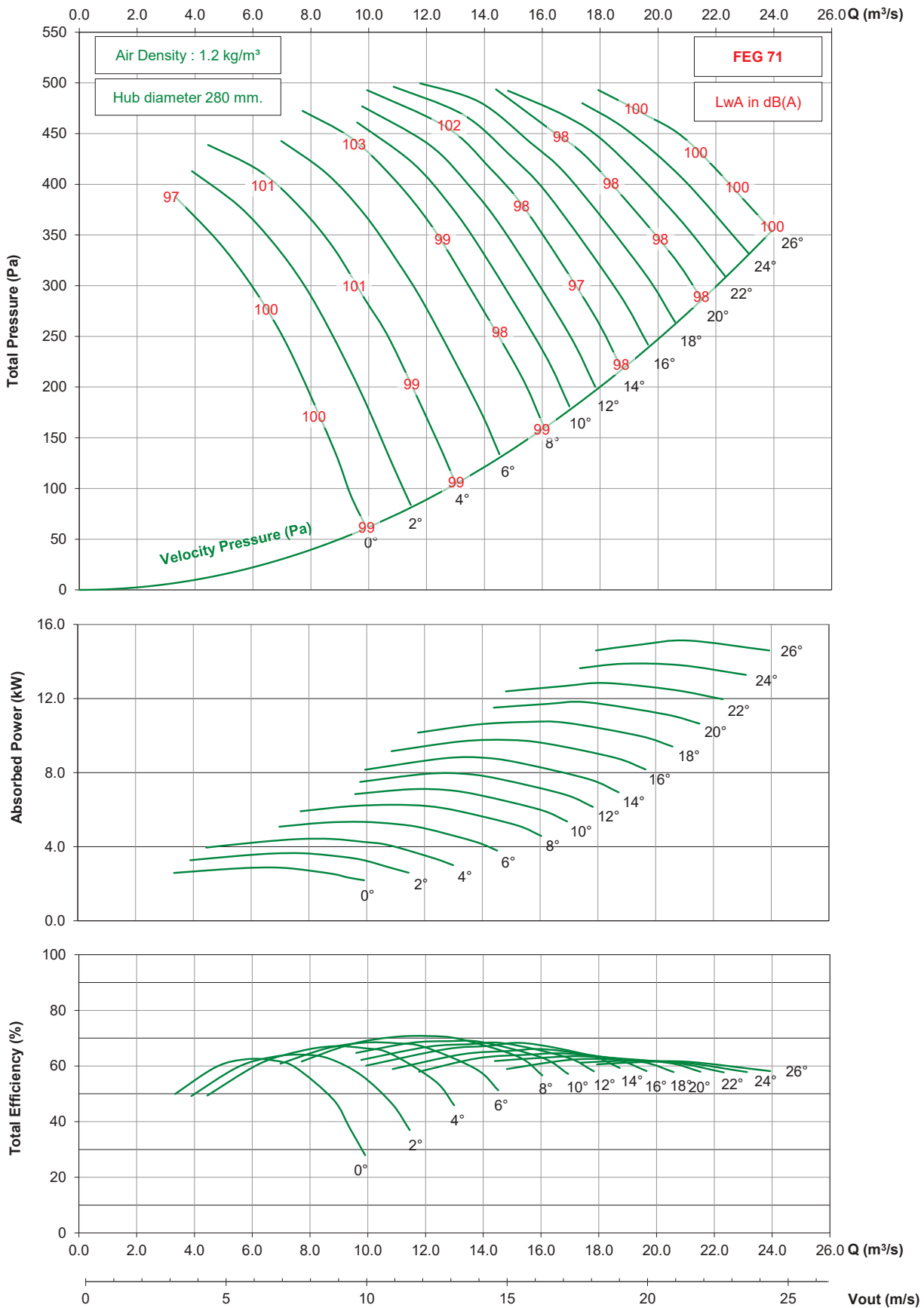

- Performance certified for installation type D - ducted inlet, ducted outlet. Performance ratings do not include the effects of appurtenances (accessories).  
 - The A-weighted sound ratings shown have been calculated per AMCA International Standard 301. Values shown are for inlet Lw(A) sound power levels for installation type D - ducted inlet, ducted outlet. Ratings include the effects of duct end correction.

T  
D  
A

S  
e  
r  
i  
e  
s

# TDA1120 / 14AA / 9-12 (280)

875 rpm - 60 Hz

KRUGER

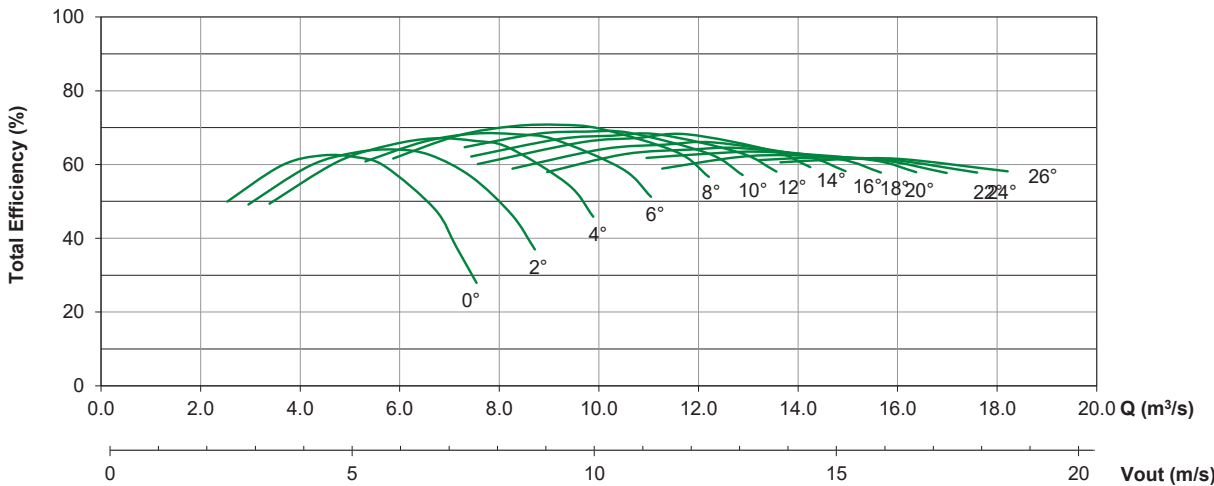
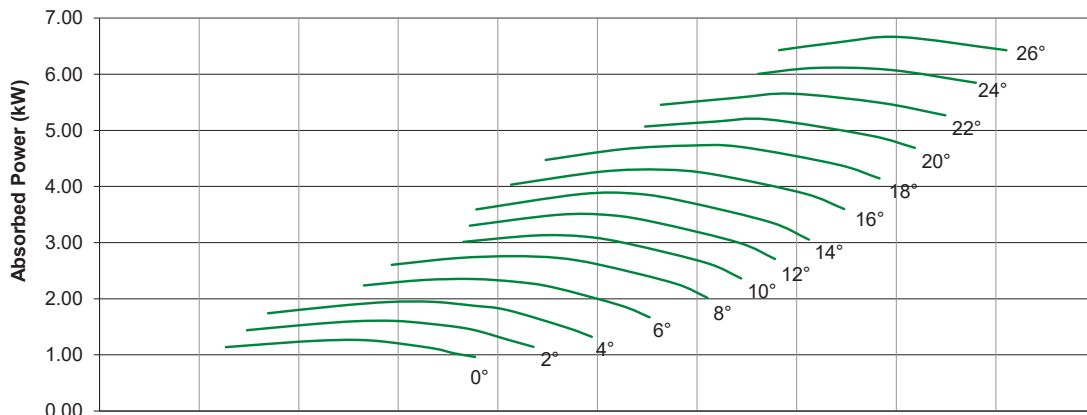
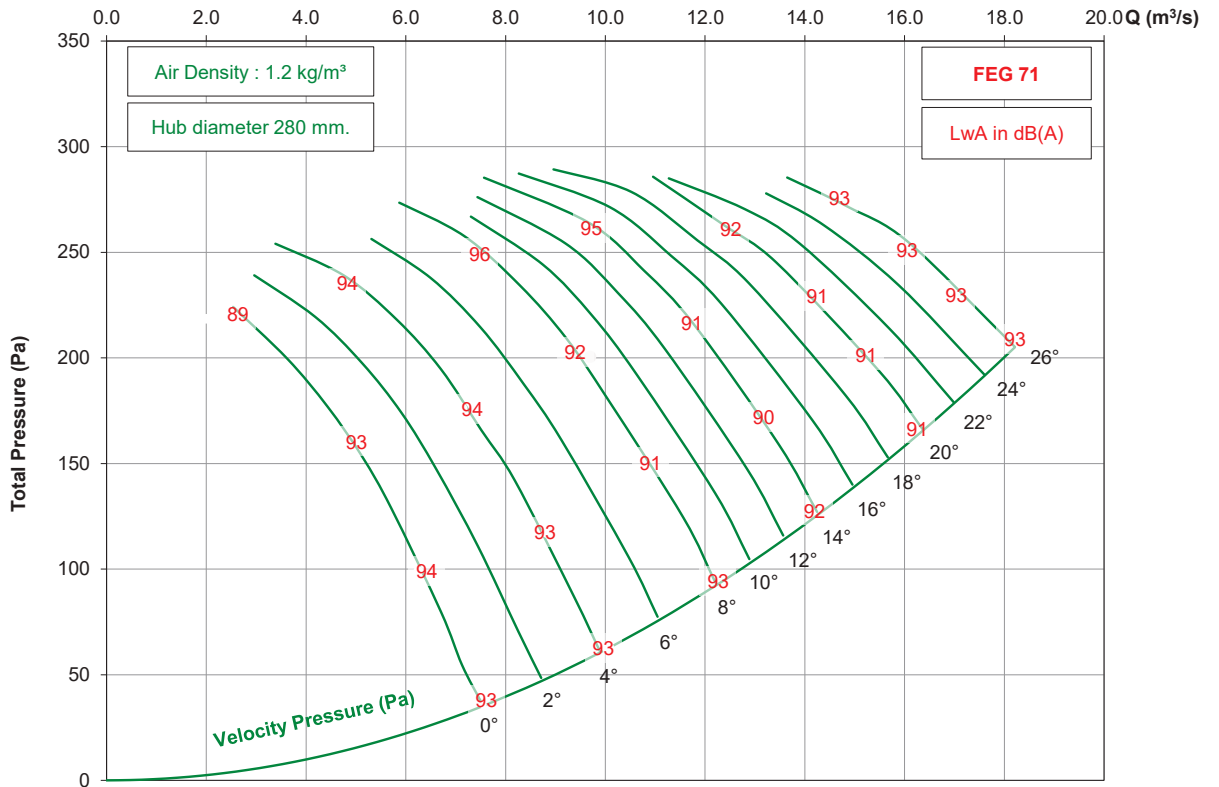

- Performance certified is for installation type D - ducted inlet, ducted outlet. Performance ratings do not include the effects of appurtenances (accessories).  
 - The A-weighted sound ratings shown have been calculated per AMCA International Standard 301. Values shown are for inlet Lwi(A) sound power levels for installation type D - ducted inlet, ducted outlet. Ratings include the effects of duct end correction.

T  
D  
A  
  
S  
e  
r  
i  
e  
s

