



RCD-B Series

Downblast Centrifugal Roof Exhaust Fan



Downblast Centrifugal Roof Exhaust Fan – RCD-B



Features

RCD-B roof exhaust fan is suitable for the removal of relatively clean air from buildings. Typical applications include kitchen exhaust, laboratory fume exhaust and commercial building ventilation.

- A.** Enclosed motor compartment isolates motor and drive from exhaust air.
- B.** Aluminum alloy housing provides good appearance, light weight and weather resistance.
- C.** Skirt structure provides maximum air performance.
- D.** Motor base is adjustable for proper belt tension.
- E.** Non-overloading, backward inclined aluminum centrifugal wheel achieves high efficiency and minimum sound.
- F.** All wheels are statically and dynamically balanced to AMCA 204-G2.5 standard.
- G.** Reinforced guide vanes reduce turbulence and improve air performance.
- H.** Totally enclosed motor, IP54 protection with class F insulation.
- I.** Max air and fume stream temperature: 80°C

MODEL: RCD __ / __ -B / __

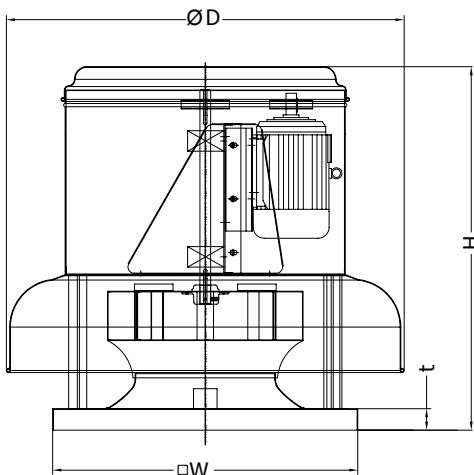
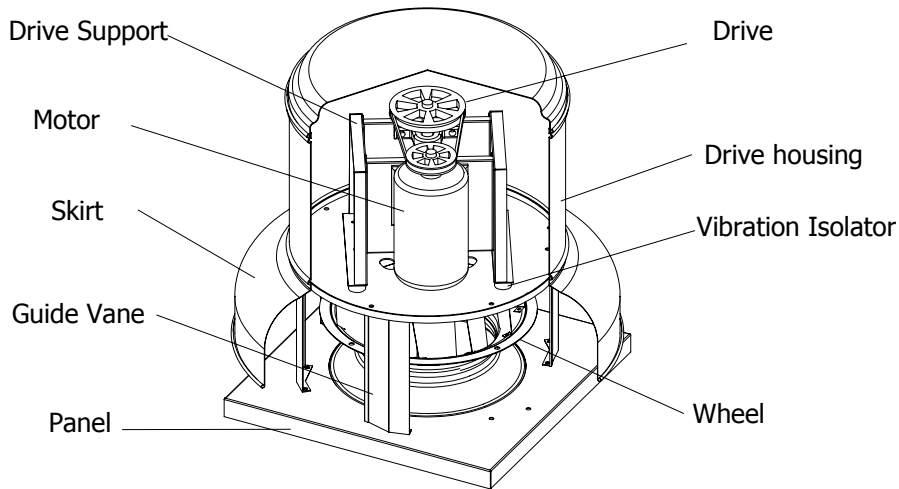
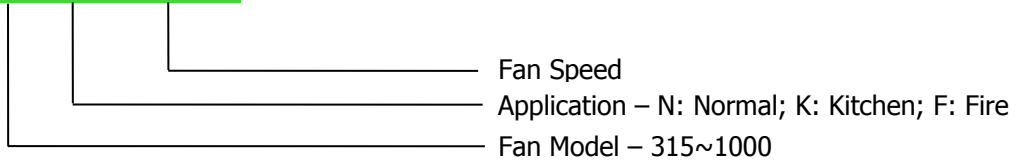

MODEL	ØD	H	t	W
RCD 315-B	800	730	40	610
RCD 355-B	800	740	40	610
RCD 400-B	926	822	50	710
RCD 450-B	926	862	50	710
RCD 500-B	1219	953	50	914
RCD 560-B	1219	993	50	914
RCD 630-B	1300	1250	60	1090
RCD 710-B	1300	1300	60	1090

- Please contact the nearest Kruger office for selection of fan models RCD 800 B and above.

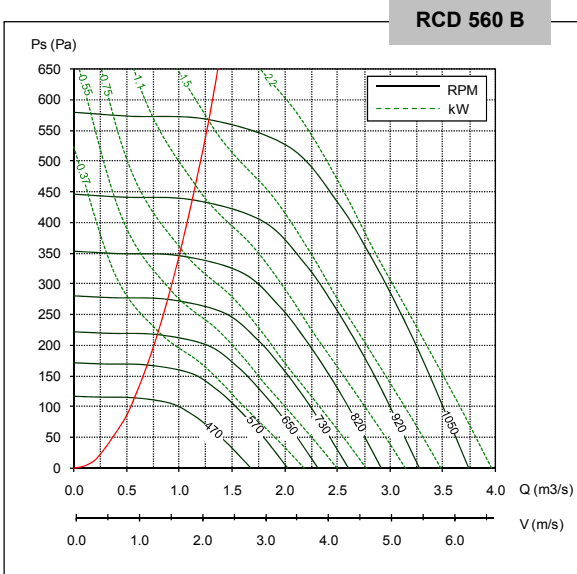
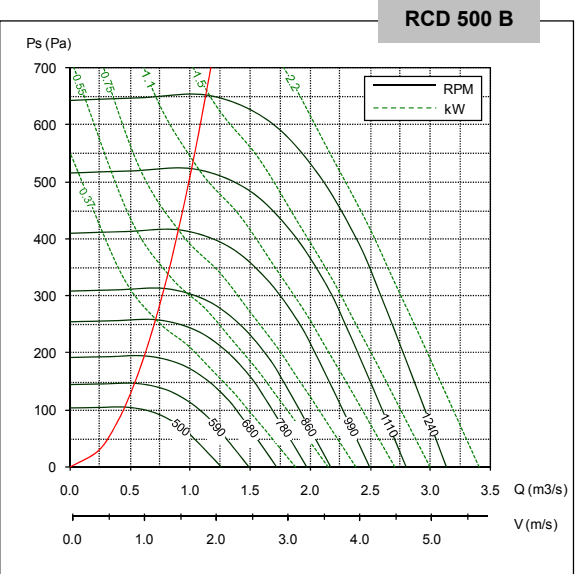
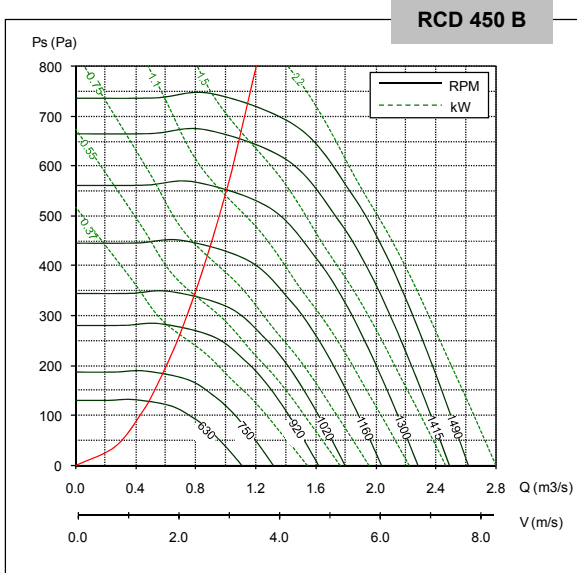
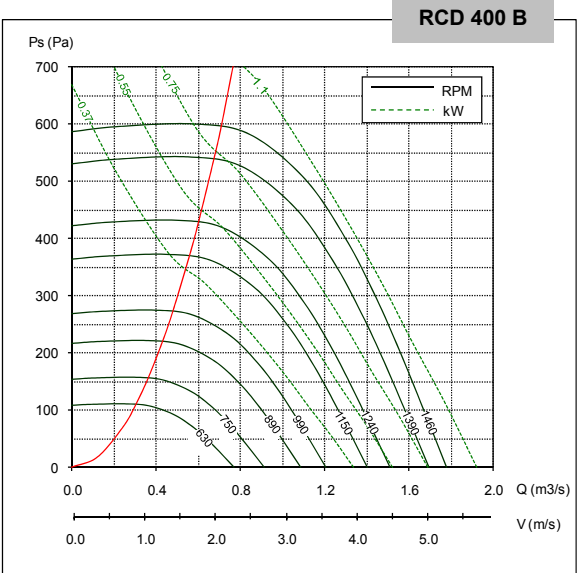
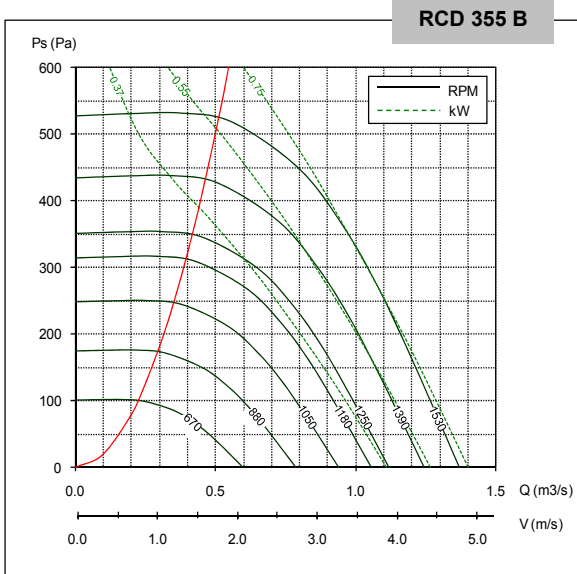
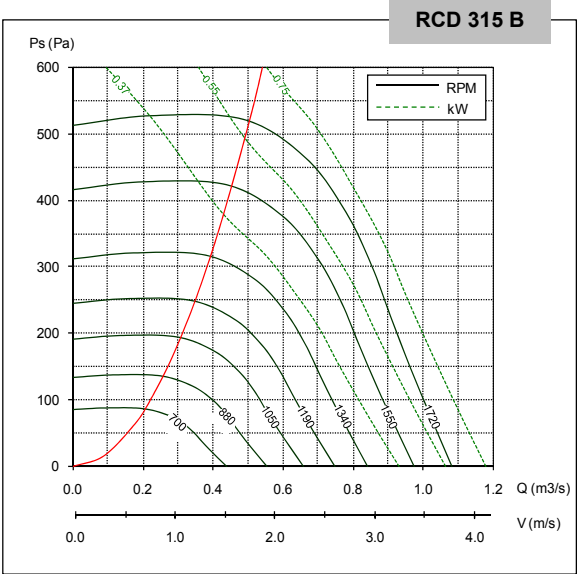

- Power rating kW does not include drive losses.

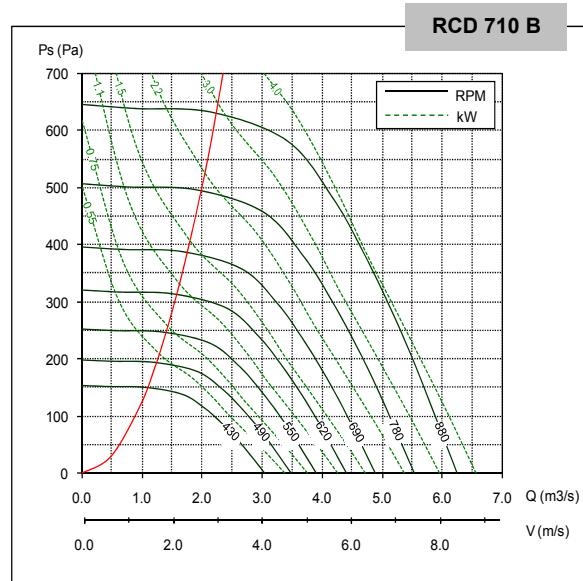
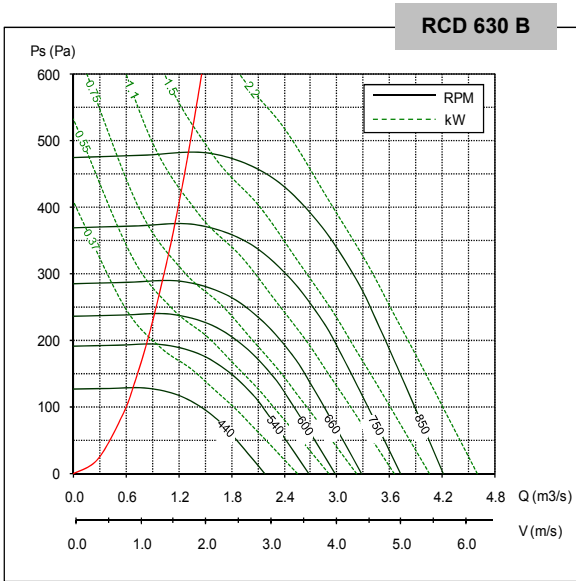

ASIA PACIFIC SHENGRUI LIMITED
 Phone +00852 56261528
 info@apacfan.com
 www.apacfan.com