



---

# VANE AXIAL FAN

DIRECT DRIVEN



# VANE AXIAL FAN DIRECT DRIVEN

## Series TDA-V



### Features

For commercial and industrial applications where large volumes of air are required at moderate to high pressure, special designed integral straightening vanes, reduced turbulence, provide high performance and low sound level.

### Construction

Double flanged casing is produced in mild steel or galvanised Steel, the impeller having manually adjustable pitch aerofoil blades is made of PPG, PAG or Aluminium.

### Finish

Available in standard finishes of galvanisation or painting.

### Operating Temperature

-20°C to +55°C

### Motors

Totally enclosed Class 'F' motor, to a min. IP54 protection are fitted as standard. Standard motor up to 2.2kW are usually supplied on DOL starting, motor 3.0kW and above are star/delta starting.

### Airflow Direction

Air flowing from impeller to motor is fitted as standard.



Kruger\* certifies that the TDA 315 -V shown herein is licensed to bear the AMCA Seal. The ratings shown are based on tests and procedures performed in accordance with AMCA publication 211 and comply with the requirements of the AMCA Certified Ratings Program.

- \*Kruger Ventilation Industries Asia Co., Ltd
- \*Guangzhou Kruger Ventilation Co., Ltd
- \*Kruger Ventilation (Taiwan) Co., Ltd
- \*Kruger Ventilation Industries (Vietnam) Co., Ltd
- \*Kruger Ventilation Industries (India) Pvt. Ltd
- \*Kruger Ventilation Industries (North India) Pvt. Ltd
- \*Kruger Ventilation Industries (Thailand) Co., Ltd
- \*Kruvent Industries (M) Sdn. Bhd
- \*P.T. Kruger Ventilation Indonesia
- \*Shanghai Kruger Ventilation Co., Ltd
- \*Wuhan Kruger Ventilation Co., Ltd

**MODEL: TDA 315-V / 12AA / 5-5 / \_ / \_**

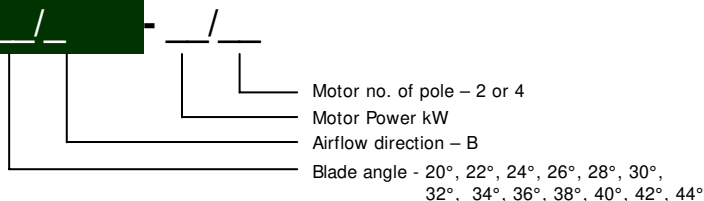

\* All Dimension in mm

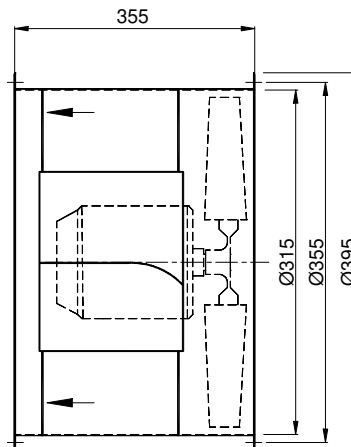
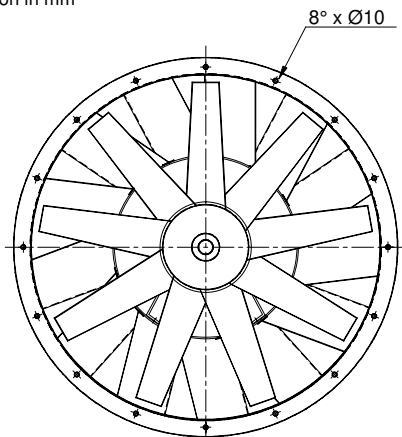

# TDA 315-V / 12AA/ 5-5/ \_ \_ / \_ 1450rpm - 50Hz

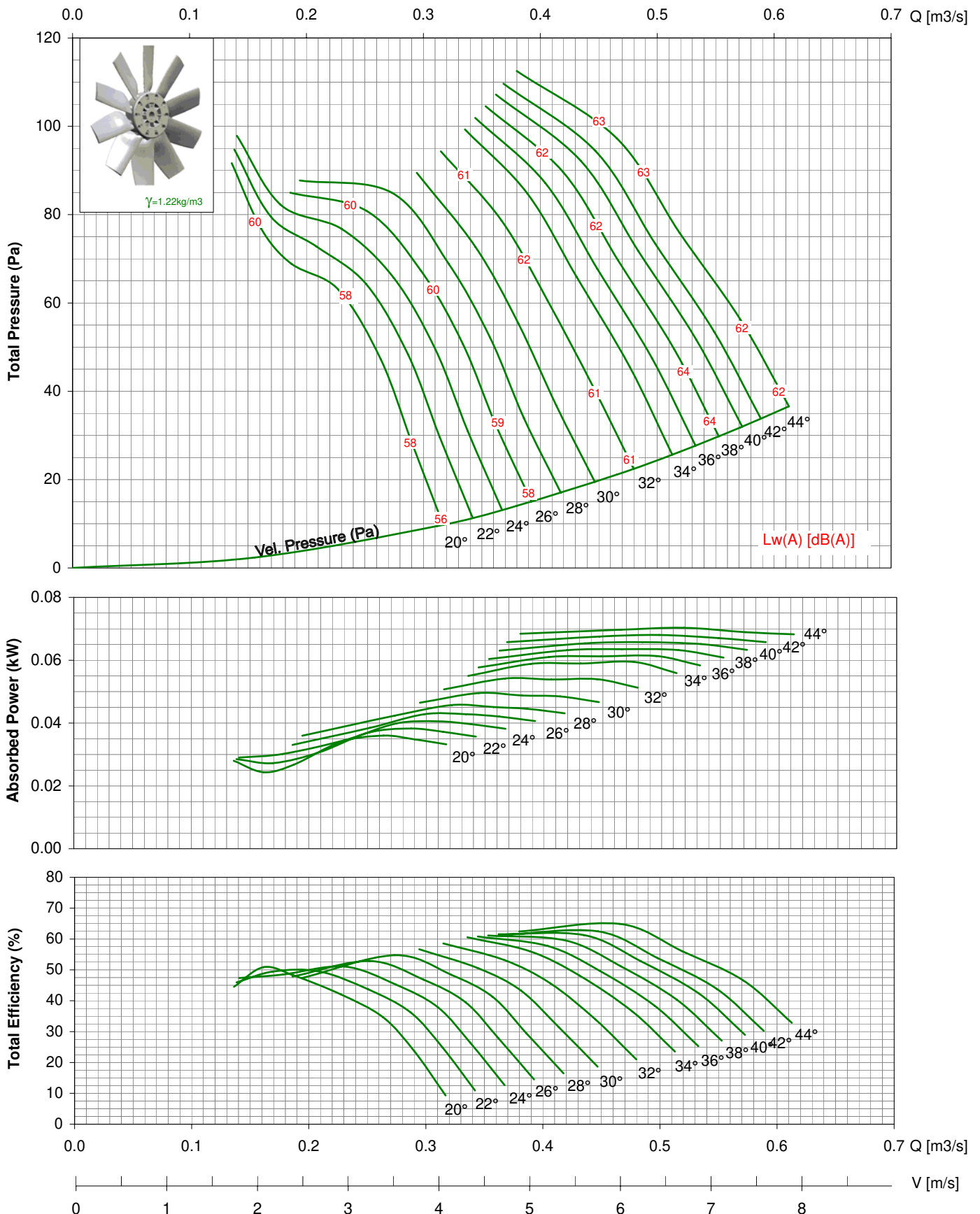

- Performance certified is for installation type D - ducted inlet, ducted outlet. Performance ratings do not include the effects of appurtenances (accessories).
- Power ratings (kW) does not include transmission losses.
- The A-weighted sound ratings shown have been calculated per AMCA Standard 301. Values shown are for inlet Lwi(A) sound power level for installation type D - ducted inlet, ducted outlet, rating include the effect of duct end correction.
- The AMCA Certified Ratings applies to air performance only. dBA levels are not licensed by AMCA international.

# TDA 315-V / 12AA/ 5-5/ \_ \_ / \_ 2850rpm - 50Hz

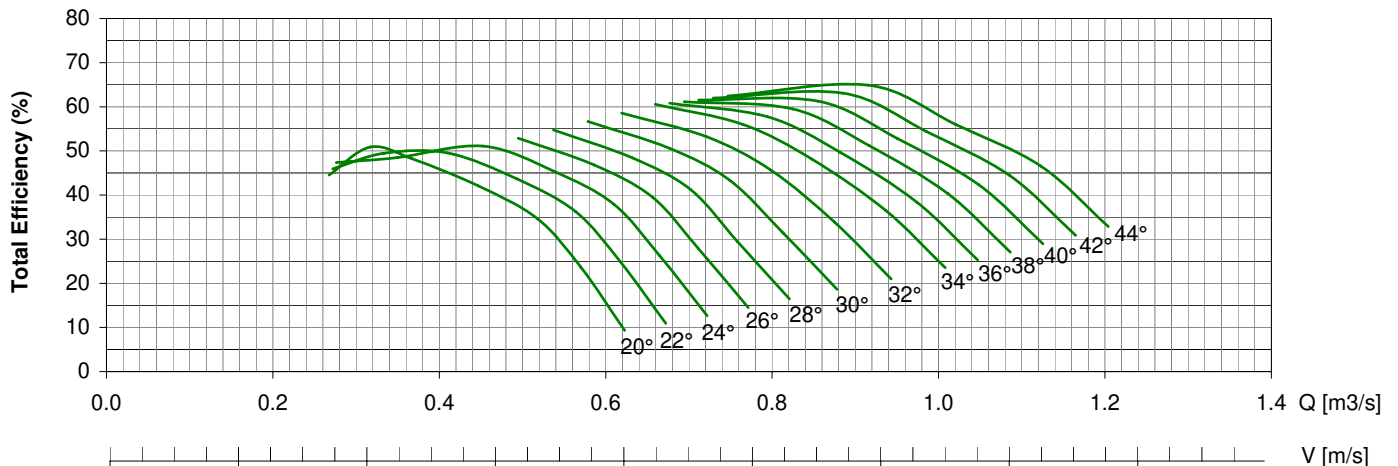
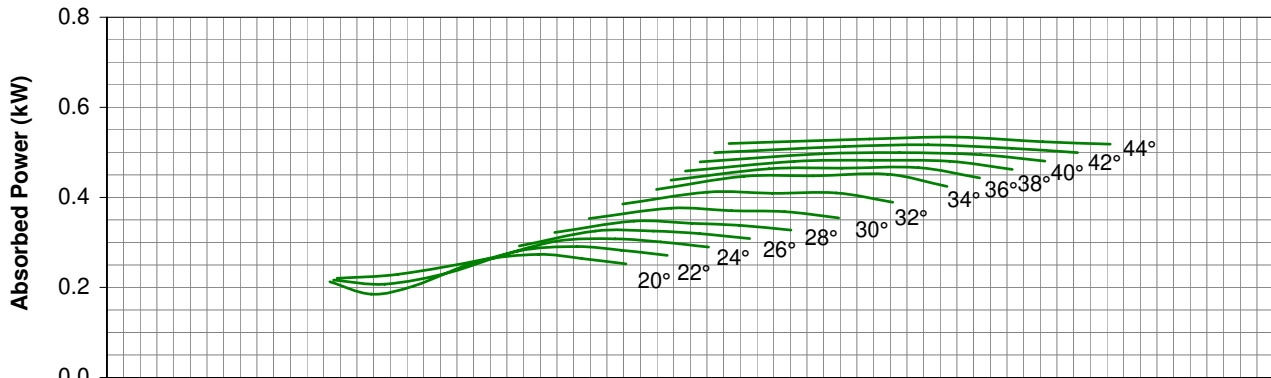
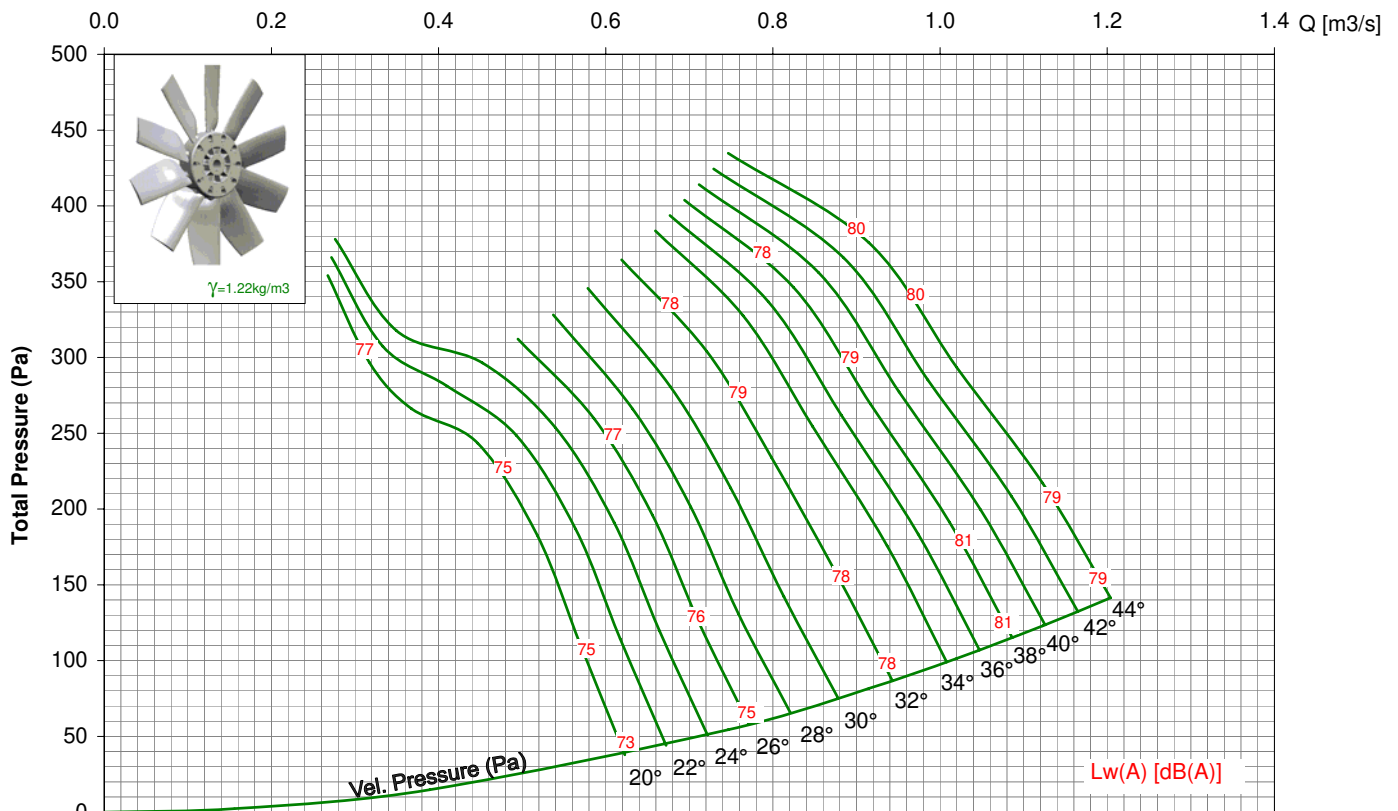

- Performance certified is for installation type D - ducted inlet, ducted outlet. Performance ratings do not include the effects of appurtenances (accessories).
- Power ratings (kW) does not include transmission losses.
- The A-weighted sound ratings shown have been calculated per AMCA Standard 301. Values shown are for inlet Lwi(A) sound power level for installation type D - ducted inlet, ducted outlet, rating include the effect of duct end correction.
- The AMCA Certified Ratings applies to air performance only. dBA levels are not licensed by AMCA international.

# TDA 315-V / 12AA/ 5-5/ \_ \_ / \_

## 1750rpm - 60Hz

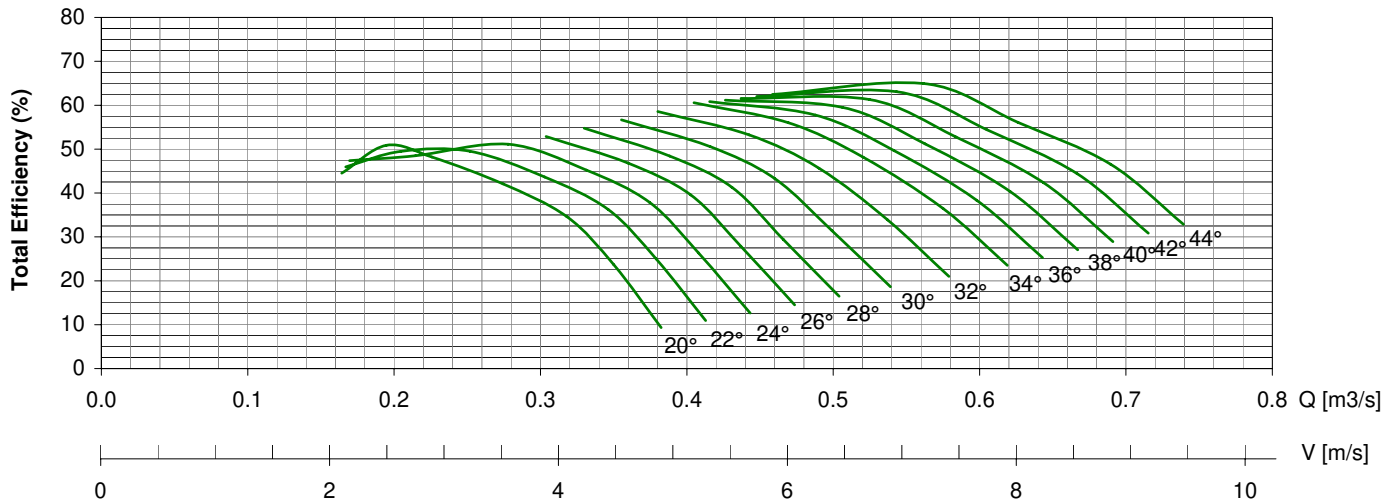
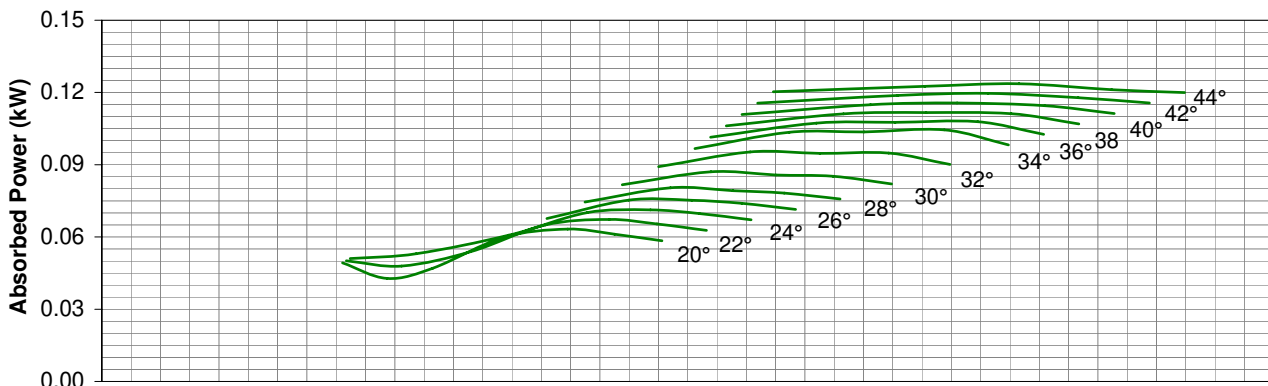
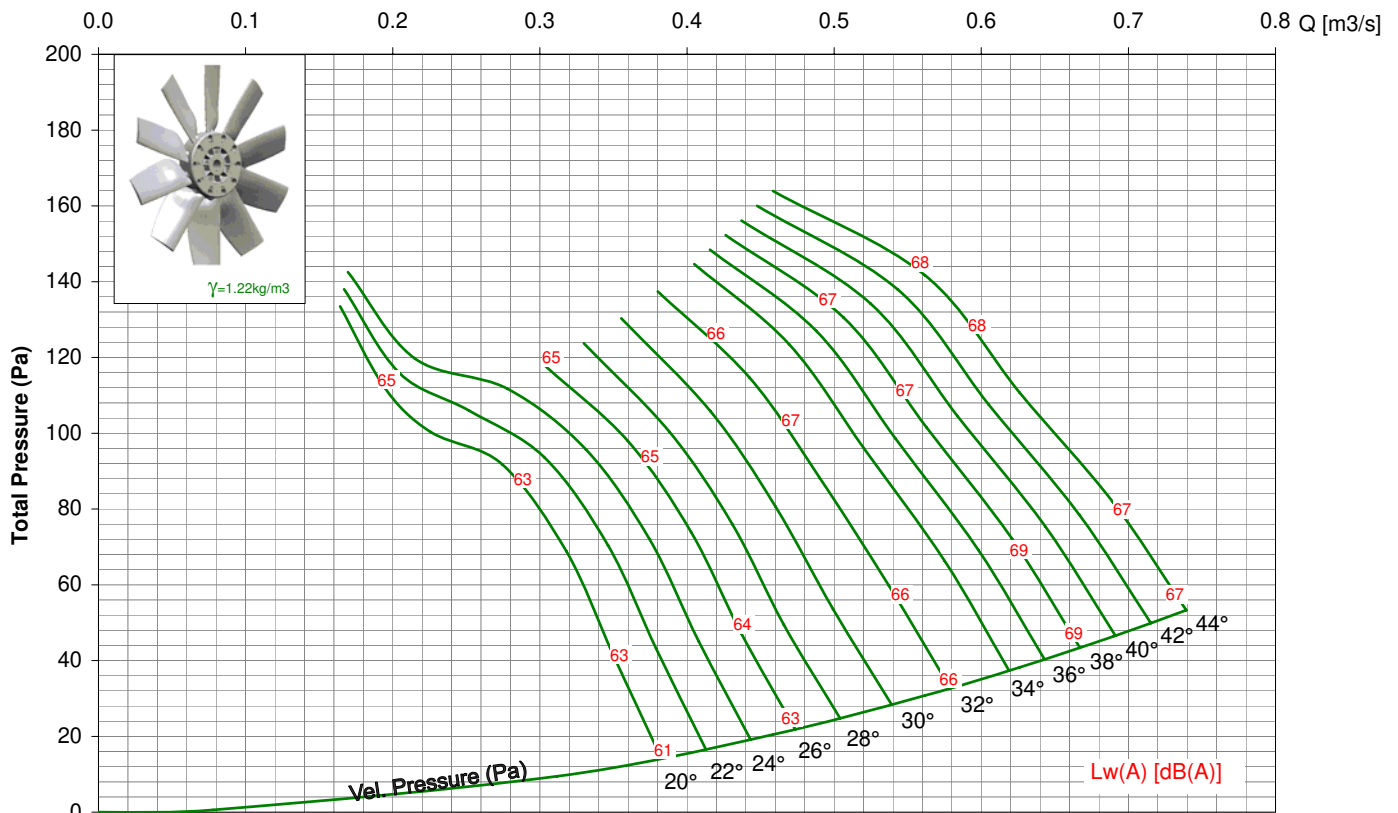

- Performance certified is for installation type D - ducted inlet, ducted outlet. Performance ratings do not include the effects of appurtenances (accessories).
- Power ratings (kW) does not include transmission losses.
- The A-weighted sound ratings shown have been calculated per AMCA Standard 301. Values shown are for inlet Lwi(A) sound power level for installation type D - ducted inlet, ducted outlet, rating include the effect of duct end correction.
- The AMCA Certified Ratings applies to air performance only. dBA levels are not licensed by AMCA international.

# TDA 315-V / 12AA/ 5-5/ \_\_ / \_

## 3450rpm - 60Hz

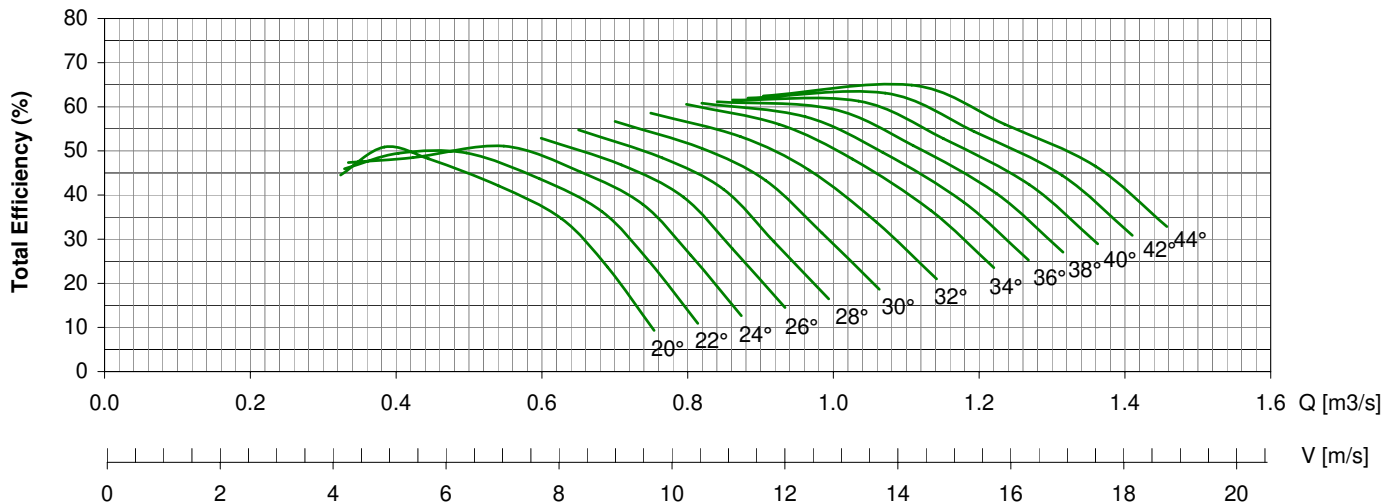
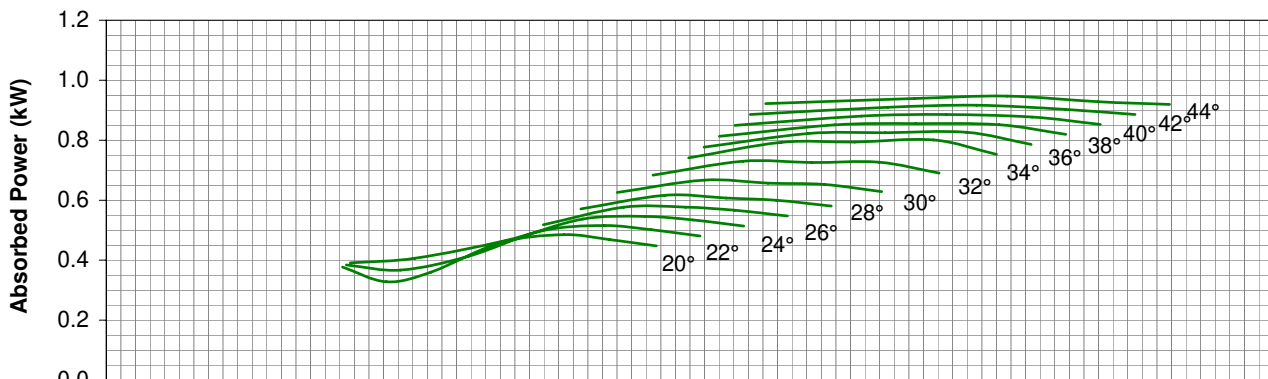
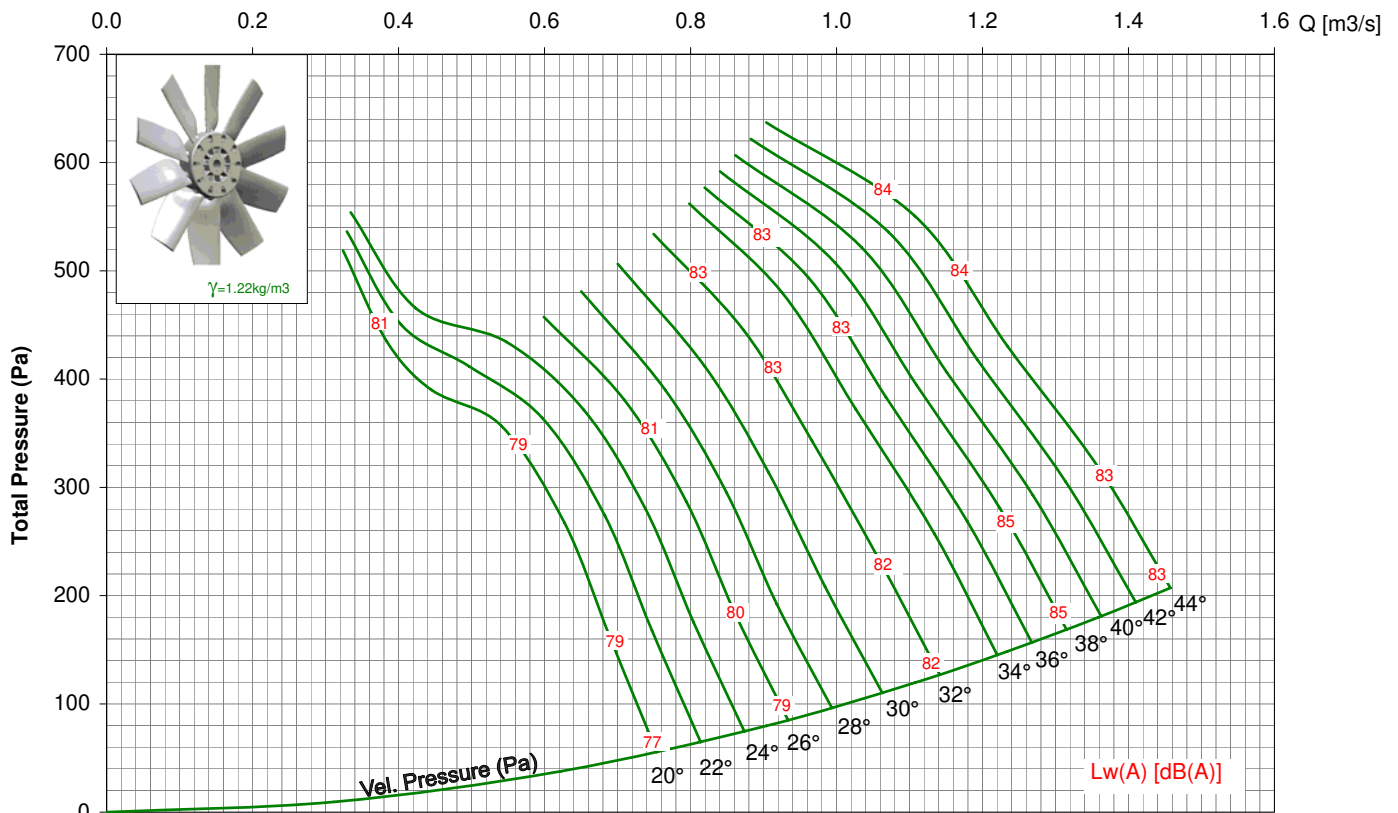

- Performance certified is for installation type D - ducted inlet, ducted outlet. Performance ratings do not include the effects of appurtenances (accessories).
- Power ratings (kW) does not include transmission losses.
- The A-weighted sound ratings shown have been calculated per AMCA Standard 301. Values shown are for inlet Lwi(A) sound power level for installation type D - ducted inlet, ducted outlet, rating include the effect of duct end correction.
- The AMCA Certified Ratings applies to air performance only. dBA levels are not licensed by AMCA international.

# VANE AXIAL FAN DIRECT DRIVEN

## Series TDA-V



### Features

For commercial and industrial applications where large volumes of air are required at moderate to high pressure, special designed integral straightening vanes, reduced turbulence, provide high performance and low sound level.

### Construction

Double flanged casing is produced in mild steel or galvanised Steel, the impeller having manually adjustable pitch aerofoil blades is made of PPG, PAG or Aluminium.

### Finish

Available in standard finishes of galvanisation or painting.

### Operating Temperature

-20°C to +55°C

### Motors

Totally enclosed Class 'F' motor, to a min. IP54 protection are fitted as standard. Standard motor up to 2.2kW are usually supplied on DOL starting, motor 3.0kW and above are star/delta starting.

### Airflow Direction

Air flowing from impeller to motor is fitted as standard.



Kruger\* certifies that the TDA 355 -V shown herein is licensed to bear the AMCA Seal. The ratings shown are based on tests and procedures performed in accordance with AMCA publication 211 and comply with the requirements of the AMCA Certified Ratings Program.

- \*Kruger Ventilation Industries Asia Co., Ltd
- \*Guangzhou Kruger Ventilation Co., Ltd
- \*Kruger Ventilation (Taiwan) Co., Ltd
- \*Kruger Ventilation Industries (Vietnam) Co., Ltd
- \*Kruger Ventilation Industries (India) Pvt. Ltd
- \*Kruger Ventilation Industries (North India) Pvt. Ltd
- \*Kruger Ventilation Industries (Thailand) Co., Ltd
- \*Kruvent Industries (M) Sdn. Bhd
- \*P.T. Kruger Ventilation Indonesia
- \*Shanghai Kruger Ventilation Co., Ltd
- \*Wuhan Kruger Ventilation Co., Ltd

**MODEL: TDA 355-V / 12AA / 5-5 / \_ / \_**

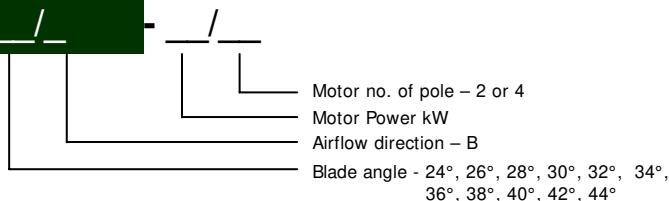

\* All Dimension in mm

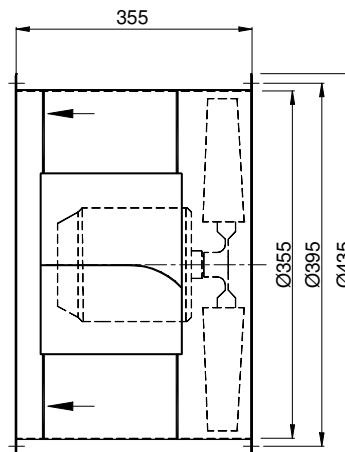
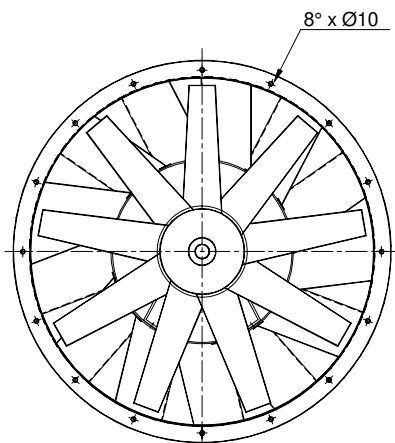

# TDA 355-V / 12AA/ 5-5/ \_ \_ / \_ 1450rpm - 50Hz

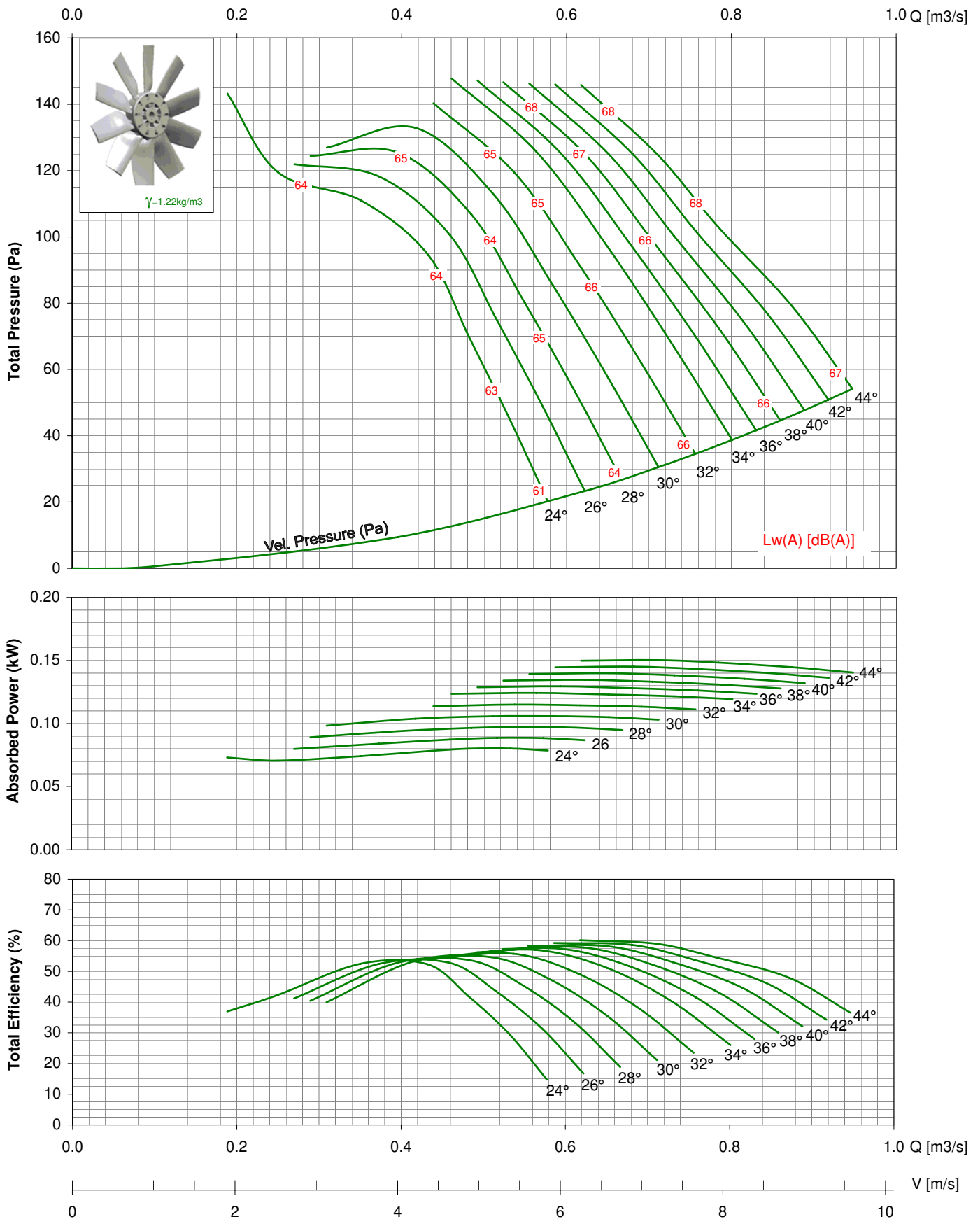

- Performance certified is for installation type D - ducted inlet, ducted outlet. Performance ratings do not include the effects of appurtenances (accessories).
- Power ratings (kW) does not include transmission losses.
- The A-weighted sound ratings shown have been calculated per AMCA Standard 301. Values shown are for inlet Lwi(A) sound power level for installation type D - ducted inlet, ducted outlet, rating include the effect of duct end correction.

# TDA 355-V / 12AA/ 5-5/ \_ \_ / \_

## 2850rpm - 50Hz

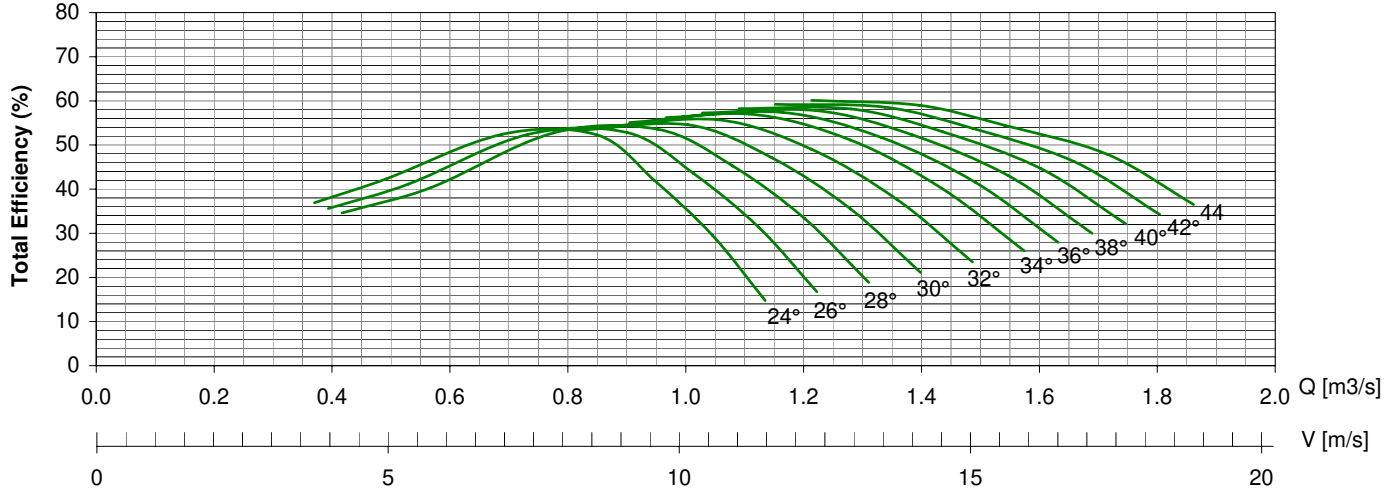
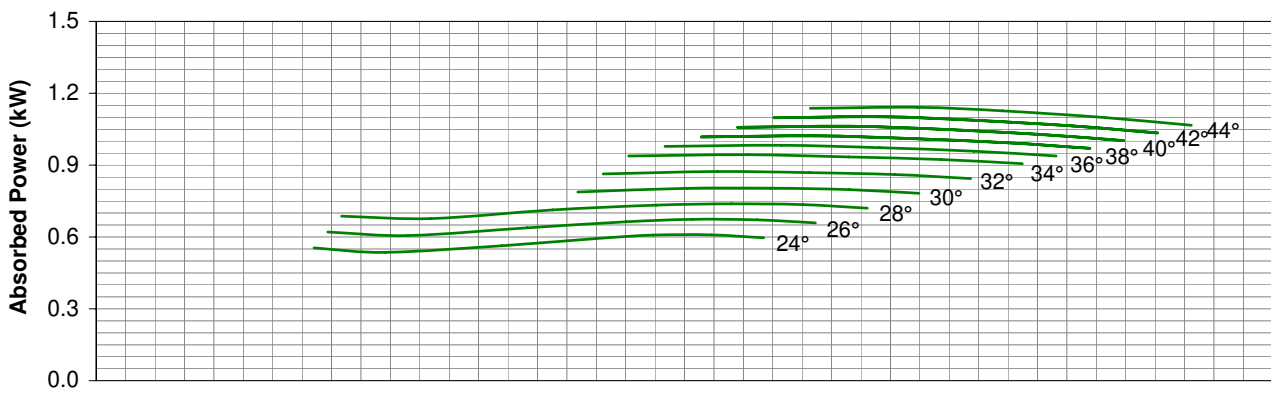
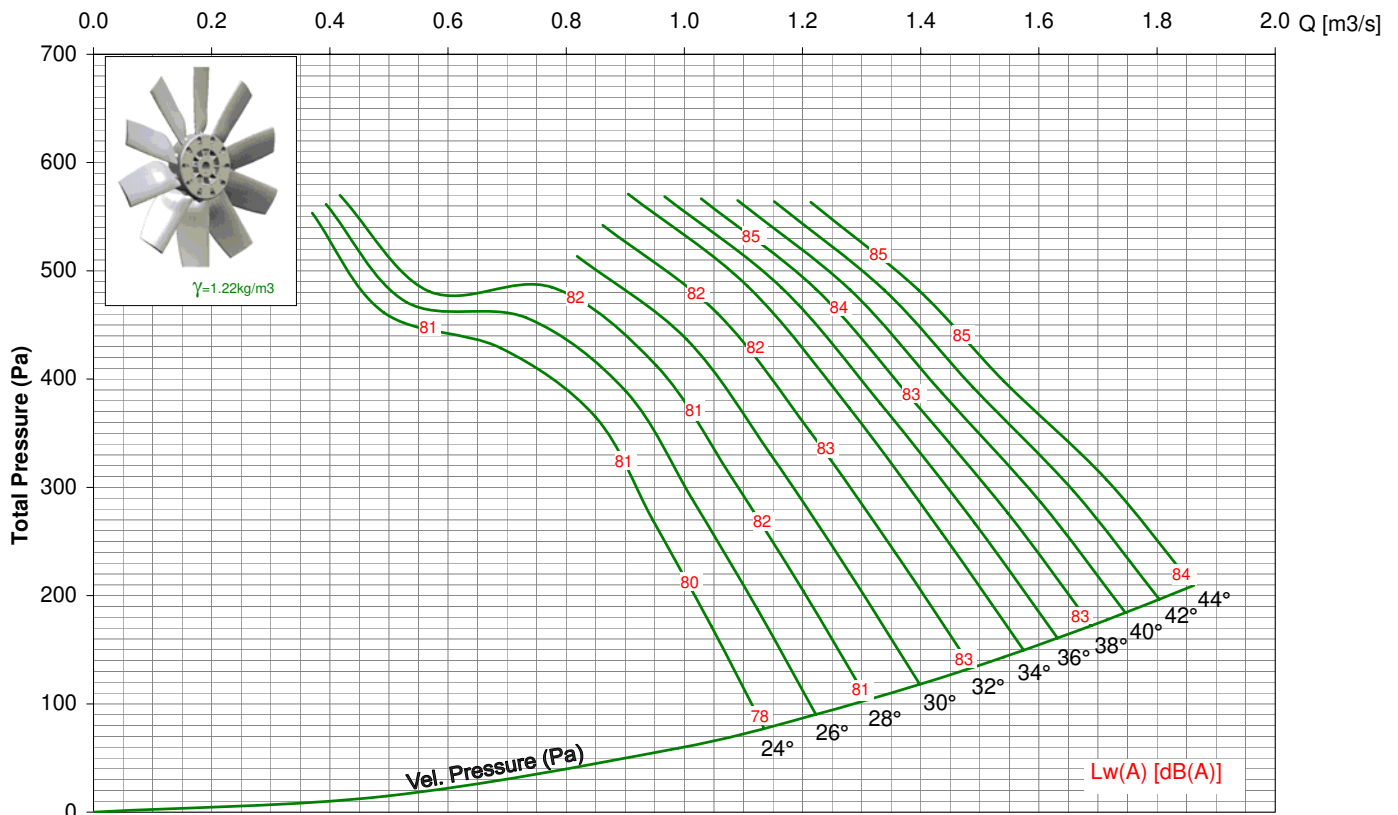

- Performance certified is for installation type D - ducted inlet, ducted outlet. Performance ratings do not include the effects of appurtenances (accessories).
- Power ratings (kW) does not include transmission losses.
- The A-weighted sound ratings shown have been calculated per AMCA Standard 301. Values shown are for inlet Lwi(A) sound power level for installation type D - ducted inlet, ducted outlet, rating include the effect of duct end correction.
- The AMCA Certified Ratings Seal applies to air performance only. dBA levels are not licensed by AMCA international.

# TDA 355-V / 12AA/ 5-5/ \_\_ / \_

## 1750rpm - 60Hz

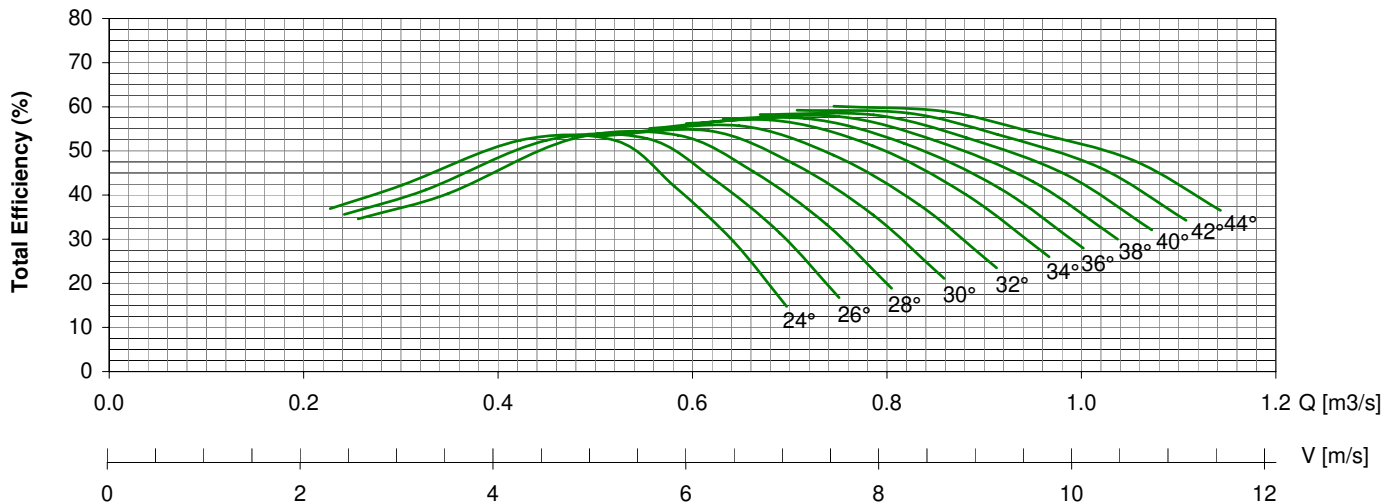
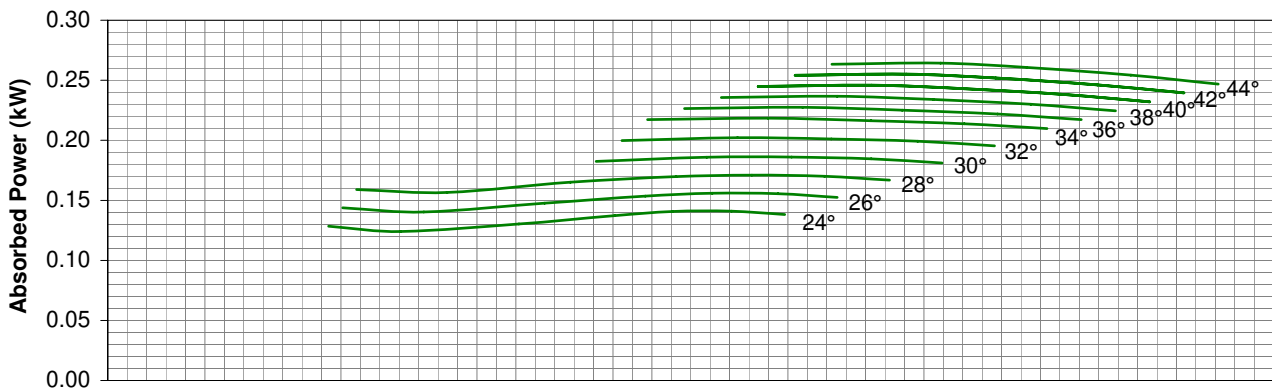
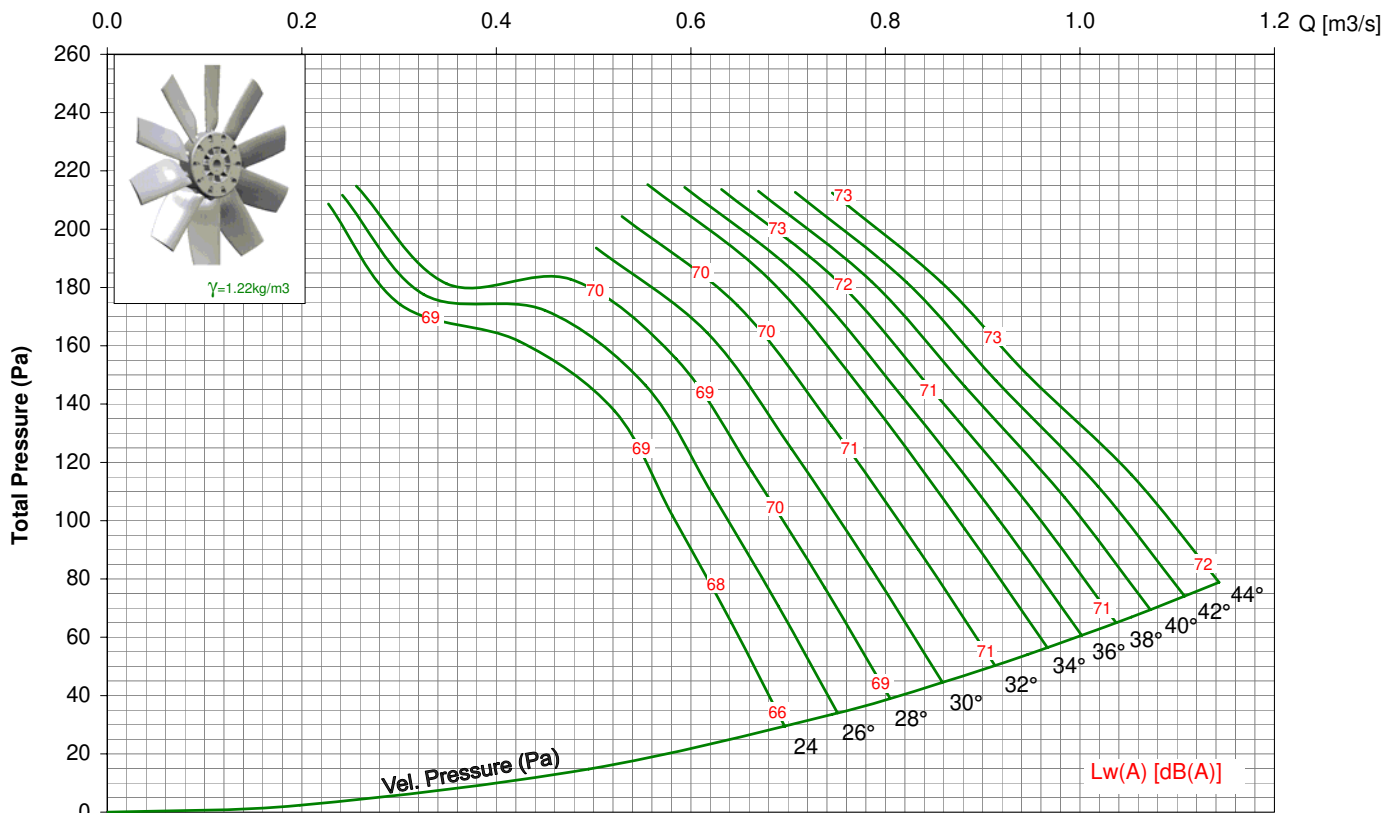

- Performance certified is for installation type D - ducted inlet, ducted outlet. Performance ratings do not include the effects of appurtenances (accessories).
- Power ratings (kW) does not include transmission losses.
- The A-weighted sound ratings shown have been calculated per AMCA Standard 301. Values shown are for inlet L<sub>wi</sub>(A) sound power level for installation type D - ducted inlet, ducted outlet, rating include the effect of duct end correction.
- The AMCA Certified Ratings Seal applies to air performance only. dBA levels are not licensed by AMCA international.

# TDA 355-V / 12AA/ 5-5/ \_\_ / \_

## 3450rpm - 60Hz

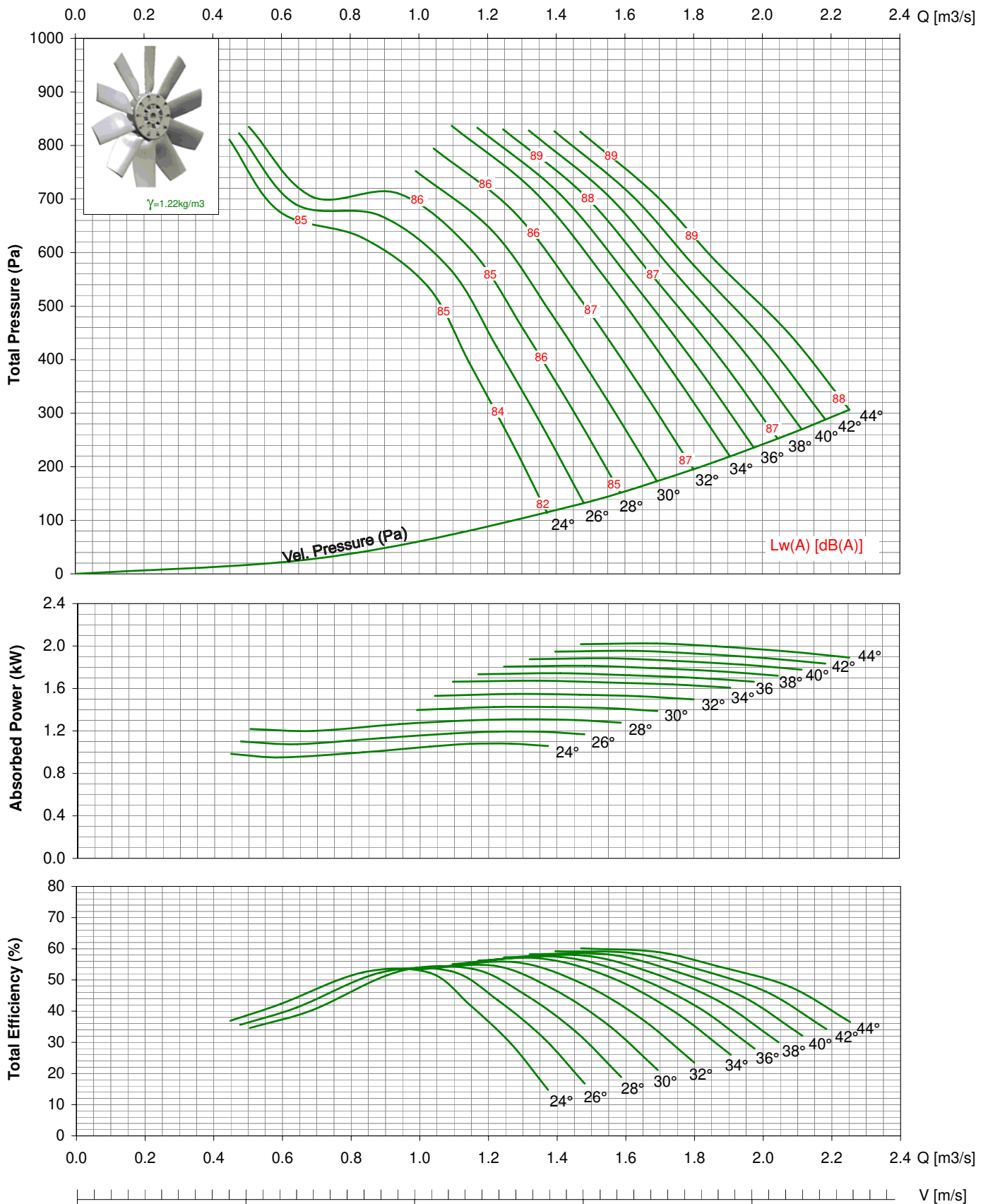

- Performance certified is for installation type D - ducted inlet, ducted outlet. Performance ratings do not include the effects of appurtenances (accessories).
- Power ratings (kW) does not include transmission losses.
- The A-weighted sound ratings shown have been calculated per AMCA Standard 301. Values shown are for inlet  $L_{wi}(A)$  sound power level for installation type D - ducted inlet, ducted outlet, rating include the effect of duct end correction.



# VANE AXIAL FAN DIRECT DRIVEN

## Series TDA-V



### Features

For commercial and industrial applications where large volumes of air are required at moderate to high pressure, special designed integral straightening vanes, reduced turbulence, provide high performance and low sound level.

### Construction

Double flanged casing is produced in mild steel or galvanised Steel, the impeller having manually adjustable pitch aerofoil blades is made of PPG, PAG or pressure-casted Aluminium.

### Finish

Available in standard finishes of galvanisation or painting.

### Operating Temperature

-20°C to +55°C

### Motors

Totally enclosed Class 'F' motor, to a min. IP54 protection are fitted as standard. Standard motor up to 2.2kW are usually supplied on DOL starting, motor 3.0kW and above are star/delta starting.

### Airflow Direction

Air flowing from impeller to motor is fitted as standard.



Kruger\* certifies that the TDA 400 -V shown herein is licensed to bear the AMCA Seal. The ratings shown are based on tests and procedures performed in accordance with AMCA publication 211 and comply with the requirements of the AMCA Certified Ratings Program.

- \*Kruger Ventilation Industries Asia Co., Ltd
- \*Guangzhou Kruger Ventilation Co., Ltd
- \*Kruger Ventilation (Taiwan) Co., Ltd
- \*Kruger Ventilation Industries (Vietnam) Co., Ltd
- \*Kruger Ventilation Industries (India) Pvt. Ltd
- \*Kruger Ventilation Industries (North India) Pvt. Ltd
- \*Kruger Ventilation Industries (Thailand) Co., Ltd
- \*Kruvent Industries (M) Sdn. Bhd
- \*P.T. Kruger Ventilation Indonesia
- \*Shanghai Kruger Ventilation Co., Ltd
- \*Wuhan Kruger Ventilation Co., Ltd

**MODEL: TDA 400-V / 12AA / 5-5 / \_ / \_**

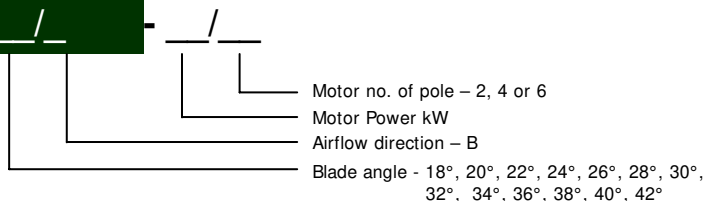

\* All Dimension in mm

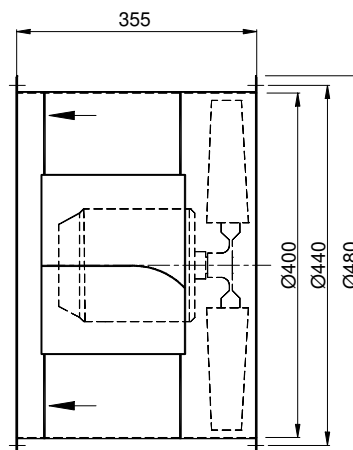
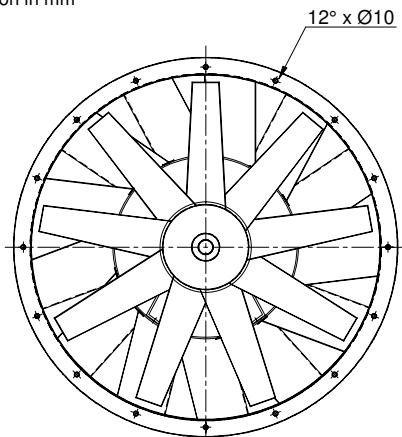

# TDA 400-V / 12AA/ 5-5/ \_\_ / \_ 950rpm - 50Hz

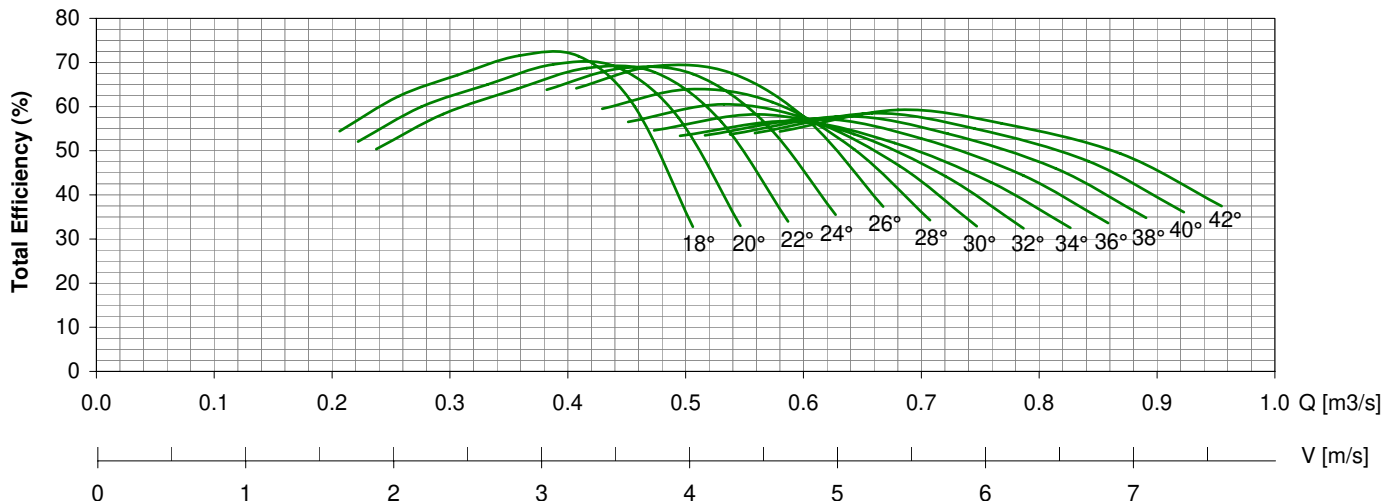
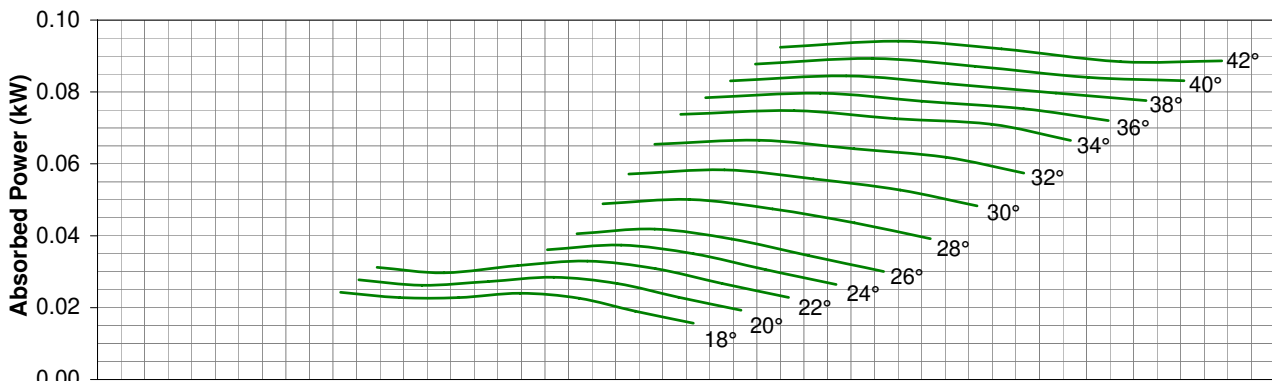
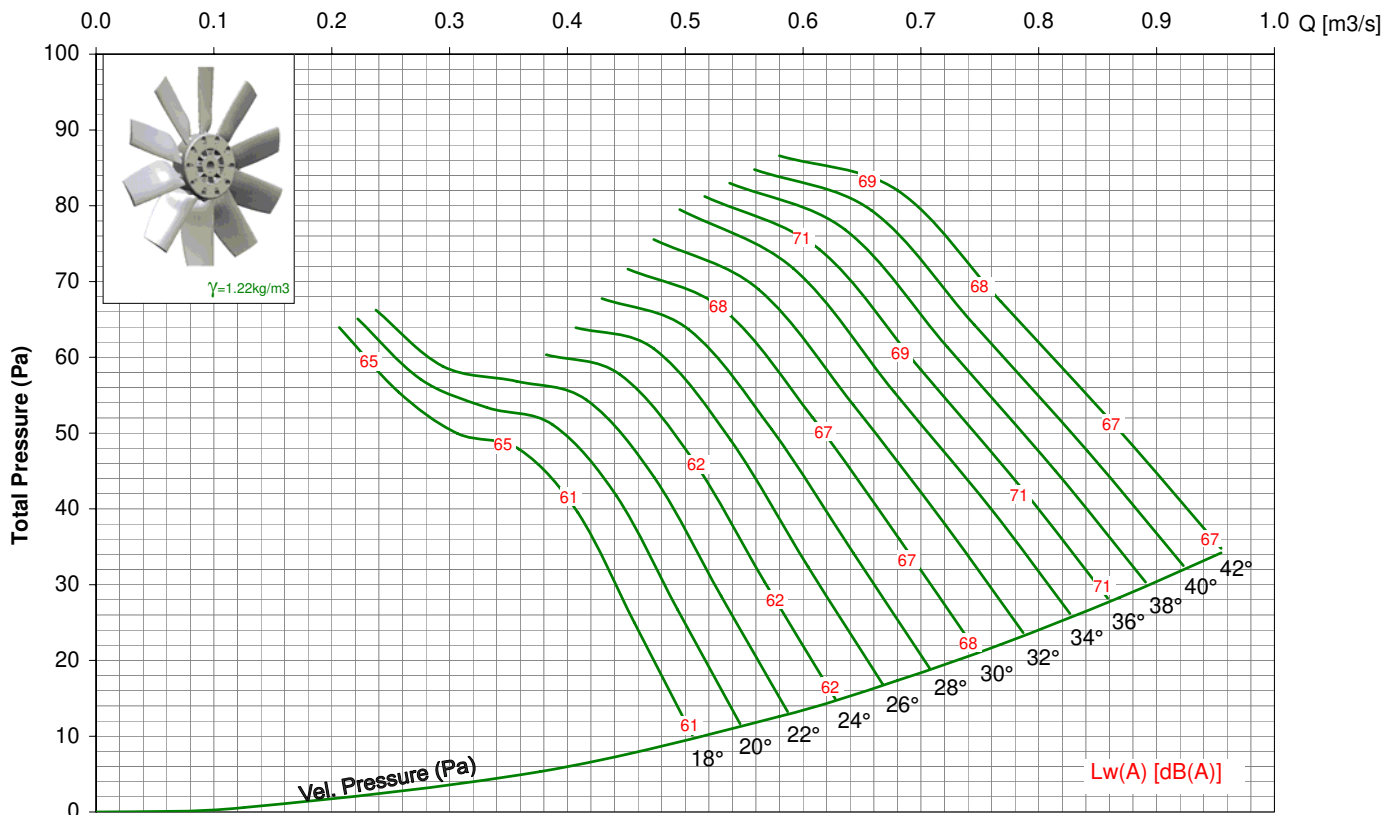

- Performance certified is for installation type D - ducted inlet, ducted outlet. Performance ratings do not include the effects of appurtenances (accessories).
- Power ratings (KW) does not include transmission losses.
- The A-weighted sound ratings shown have been calculated per AMCA Standard 301. Values shown are for inlet Lwi(A) sound power level for installation type D - ducted inlet, ducted outlet, rating include the effect of duct end correction.
- The AMCA Certified Ratings Seal applies to air performance only. dBA levels are not licensed by AMCA international.

# TDA 400-V / 12AA/ 5-5/ \_\_ / \_\_

## 1450rpm - 50Hz

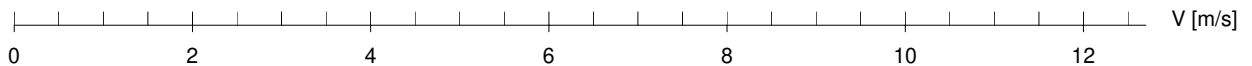
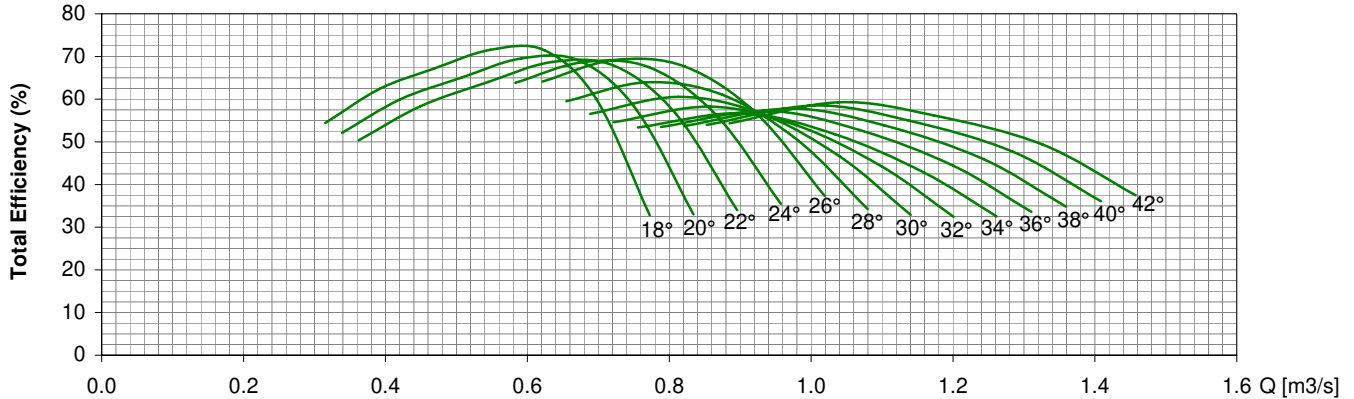
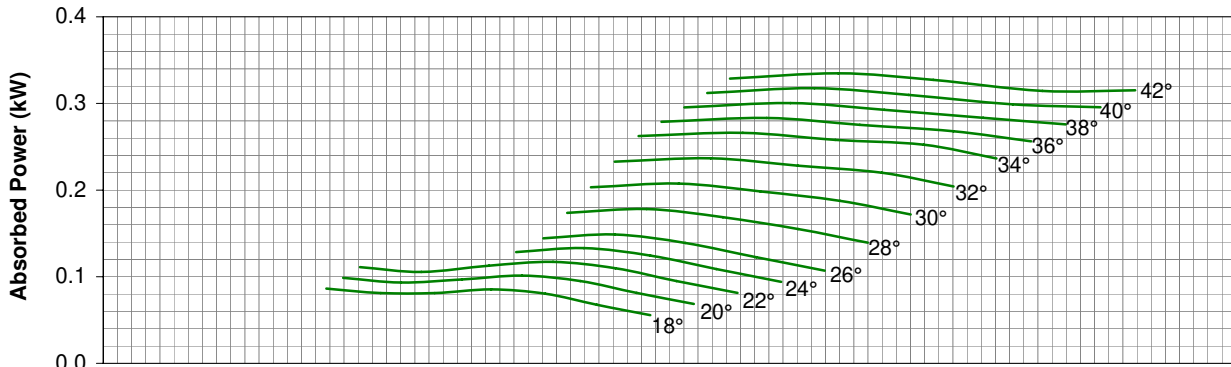
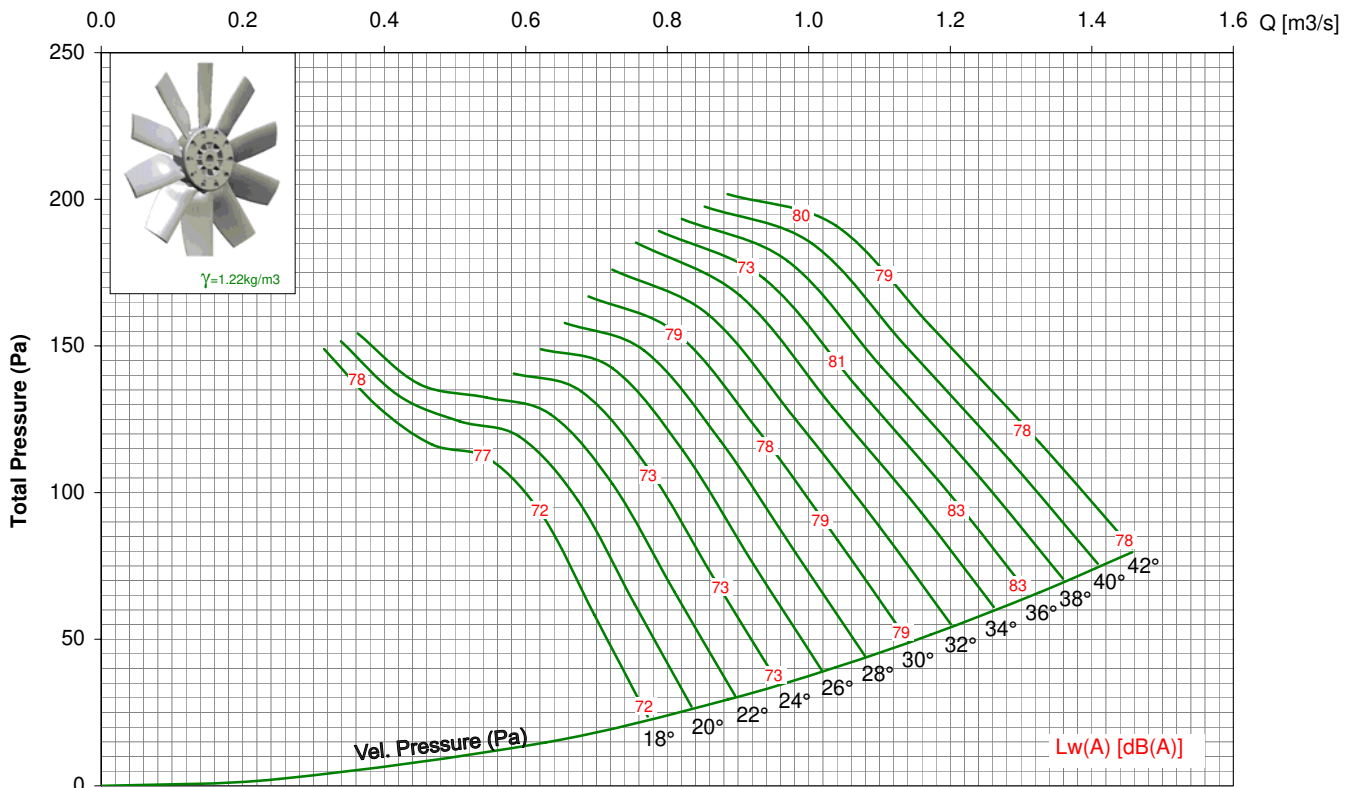

- Performance certified is for installation type D - ducted inlet, ducted outlet. Performance ratings do not include the effects of appurtenances (accessories).
- Power ratings (KW) does not include transmission losses.
- The A-weighted sound ratings shown have been calculated per AMCA Standard 301. Values shown are for inlet Lwi(A) sound power level for installation type D - ducted inlet, ducted outlet, rating include the effect of duct end correction.
- The AMCA Certified Ratings Seal applies to air performance only. dBA levels are not licensed by AMCA international.

# TDA 400-V / 12AA/ 5-5/ \_ \_ / \_ 2850rpm - 50Hz

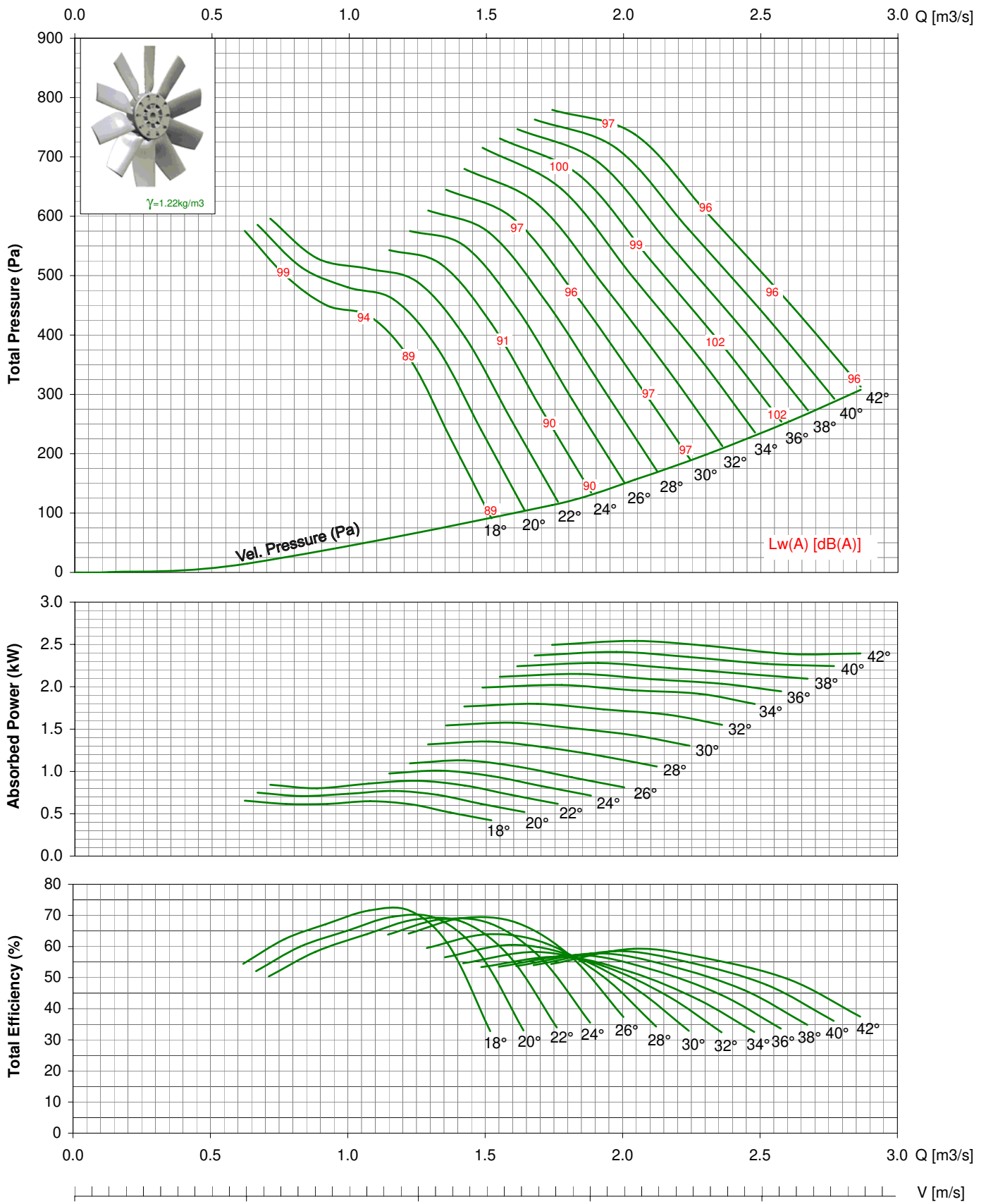

- Performance certified for installation type D - ducted inlet, ducted outlet. Performance ratings do not include the effects of appurtenances (accessories).
- Power ratings (KW) does not include transmission losses.
- The A-weighted sound ratings shown have been calculated per AMCA Standard 301. Values shown are for inlet  $L_{wi}(A)$  sound power level for installation type D - ducted inlet, ducted outlet, rating include the effect of duct end correction.
- The AMCA Certified Ratings Seal applies to air performance only. dBA levels are not licensed by AMCA international.

# TDA 400-V / 12AA/ 5-5/ \_ \_ / \_ 1150rpm - 60Hz

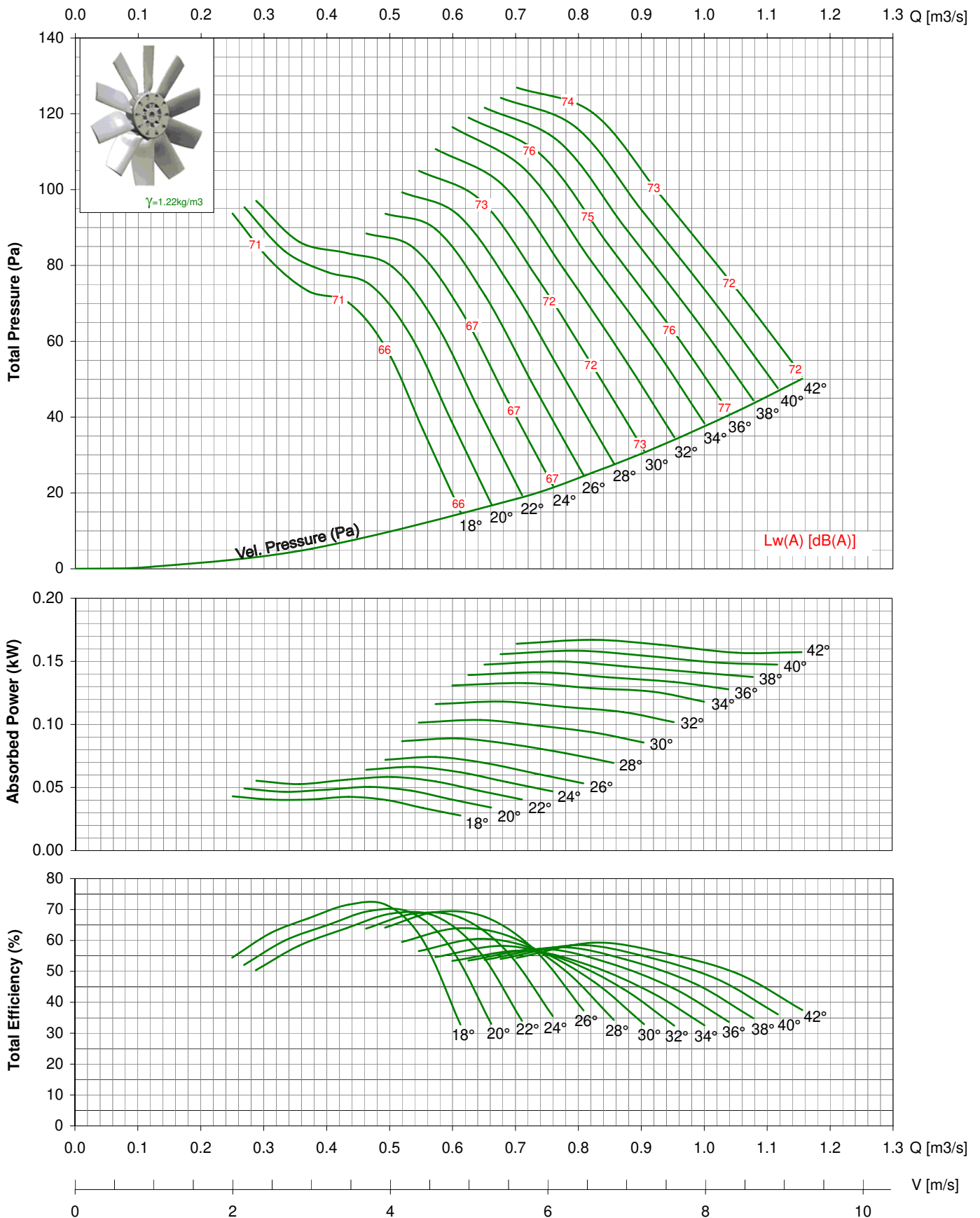

- Performance certified for installation type D - ducted inlet, ducted outlet. Performance ratings do not include the effects of appurtenances (accessories).

- Power ratings (KW) does not include transmission losses.

- The A-weighted sound ratings shown have been calculated per AMCA Standard 301. Values shown are for inlet  $L_{wi}(A)$  sound power level for installation type D - ducted inlet, ducted outlet, rating include the effect of duct end correction.

- The AMCA Certified Ratings Seal applies to air performance only. dBA levels are not licensed by AMCA international.

# TDA 400-V / 12AA/ 5-5/ \_ \_ / \_ 1750rpm - 60Hz

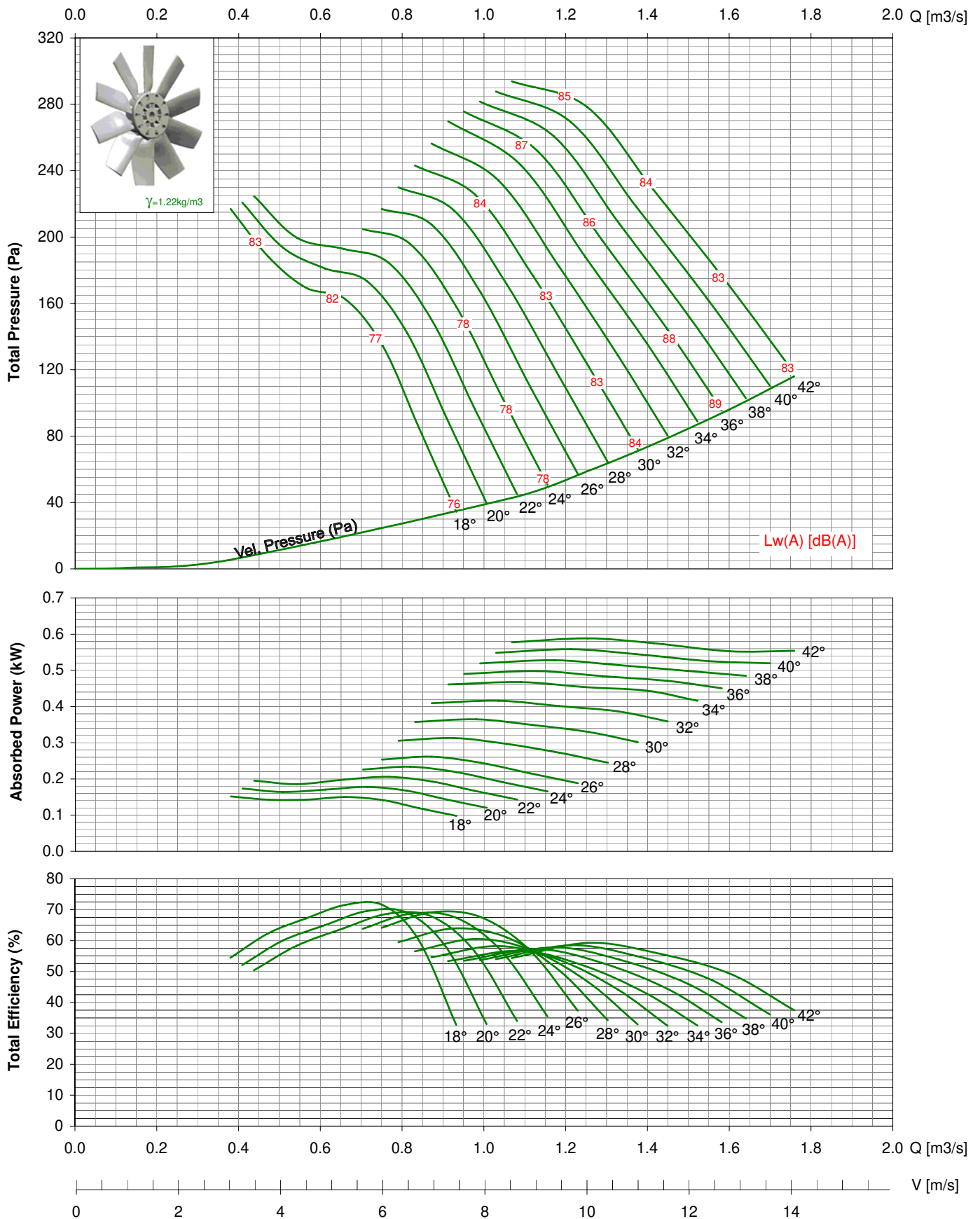

- Performance certified for installation type D - ducted inlet, ducted outlet. Performance ratings do not include the effects of appurtenances (accessories).
- Power ratings (KW) does not include transmission losses.
- The A-weighted sound ratings shown have been calculated per AMCA Standard 301. Values shown are for inlet Lwi(A) sound power level for installation type D - ducted inlet, ducted outlet, rating include the effect of duct end correction.
- The AMCA Certified Ratings Seal applies to air performance only. dBA levels are not licensed by AMCA international.

# TDA 400-V / 12AA/ 5-5/ \_\_ / \_ 3450rpm - 60Hz

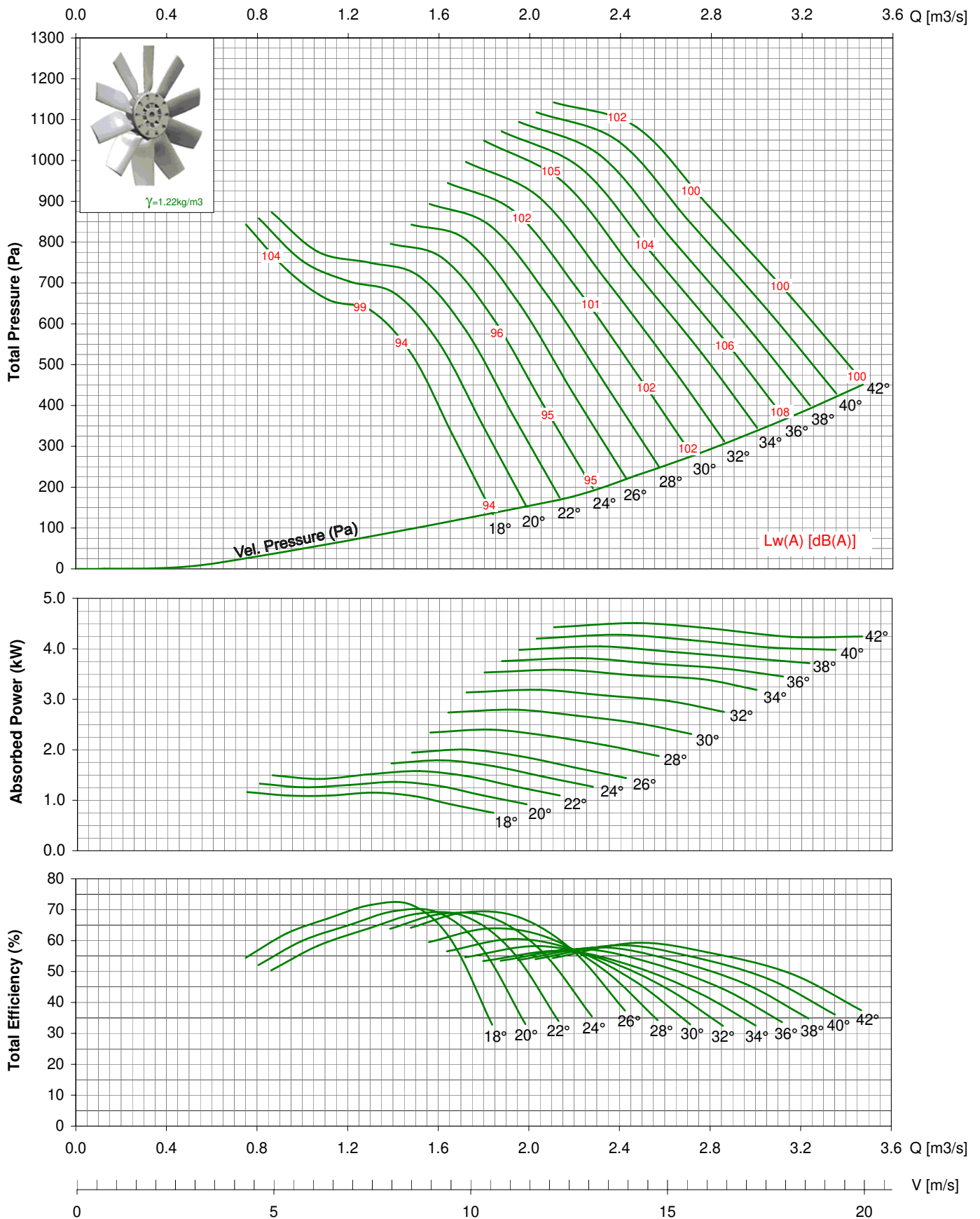

- Performance certified for installation type D - ducted inlet, ducted outlet. Performance ratings do not include the effects of appurtenances (accessories).
- Power ratings (KW) does not include transmission losses.
- The A-weighted sound ratings shown have been calculated per AMCA Standard 301. Values shown are for inlet  $L_{wi}(A)$  sound power level for installation type D - ducted inlet, ducted outlet, rating include the effect of duct end correction.
- The AMCA Certified Ratings Seal applies to air performance only. dBA levels are not licensed by AMCA international.

# VANE AXIAL FAN DIRECT DRIVEN

## Series TDA-V



### Features

For commercial and industrial applications where large volumes of air are required at moderate to high pressure, special designed integral straightening vanes, reduced turbulence, provide high performance and low sound level.

### Construction

Double flanged casing is produced in mild steel or galvanised Steel, the impeller having manually adjustable pitch aerofoil blades is made of PPG, PAG or pressure-casted Aluminium.

### Finish

Available in standard finishes of galvanisation or painting.

### Operating Temperature

-20°C to +55°C

### Motors

Totally enclosed Class 'F' motor, to a min. IP54 protection are fitted as standard. Standard motor up to 2.2kW are usually supplied on DOL starting, motor 3.0kW and above are star/delta starting.

### Airflow Direction

Air flowing from impeller to motor is fitted as standard.



Kruger\* certifies that the TDA 450 -V shown herein is licensed to bear the AMCA Seal. The ratings shown are based on tests and procedures performed in accordance with AMCA publication 211 and comply with the requirements of the AMCA Certified Ratings Program.

- \*Kruger Ventilation Industries Asia Co., Ltd
- \*Guangzhou Kruger Ventilation Co., Ltd
- \*Kruger Ventilation (Taiwan) Co., Ltd
- \*Kruger Ventilation Industries (Vietnam) Co., Ltd
- \*Kruger Ventilation Industries (India) Pvt. Ltd
- \*Kruger Ventilation Industries (North India) Pvt. Ltd
- \*Kruger Ventilation Industries (Thailand) Co., Ltd
- \*Kruvent Industries (M) Sdn. Bhd
- \*P.T. Kruger Ventilation Indonesia
- \*Shanghai Kruger Ventilation Co., Ltd
- \*Wuhan Kruger Ventilation Co., Ltd

**MODEL: TDA 450-V / 12AA / 5-5 / \_ / \_**

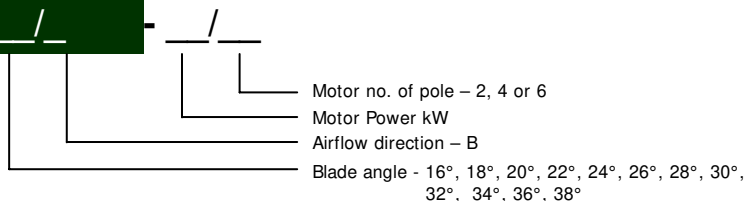

\* All Dimension in mm

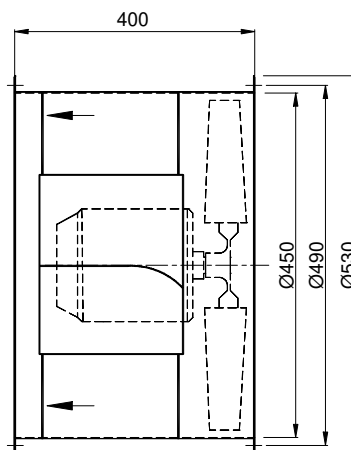
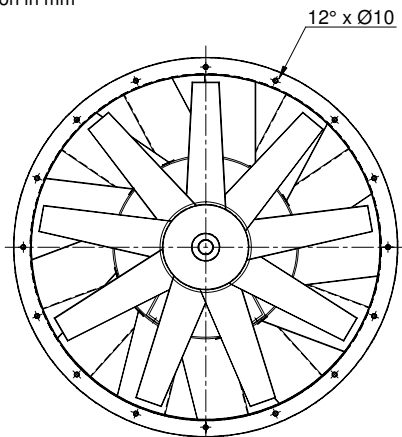

# TDA 450-V / 12AA/ 5-5/ \_\_ / \_ 950rpm - 50Hz

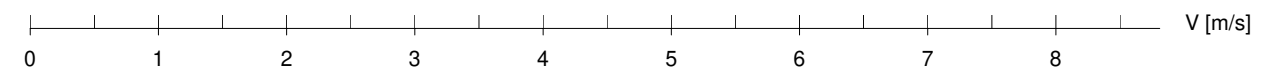
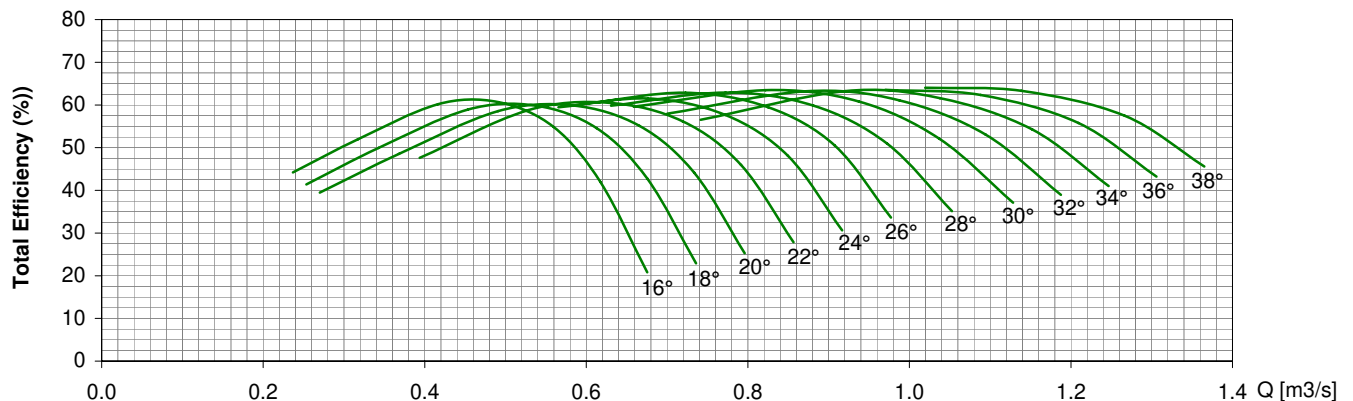
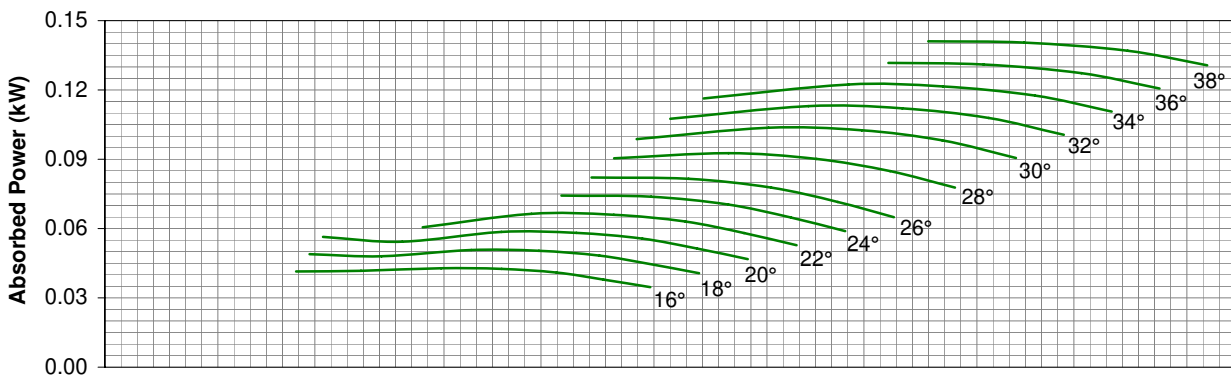
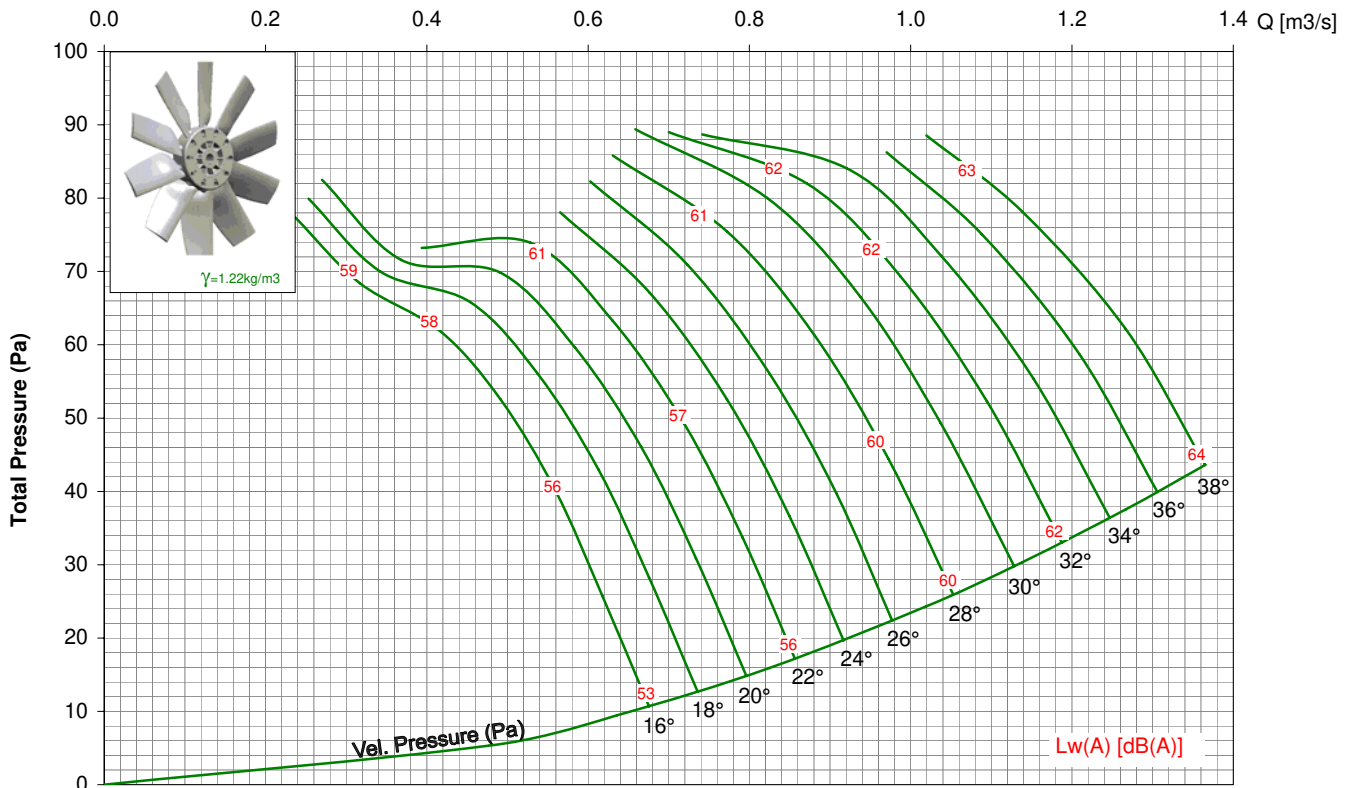

- Performance certified is for installation type D - ducted inlet, ducted outlet. Performance ratings do not include the effects of appurtenances (accessories).
- Power ratings (kW) does not include transmission losses.
- The A-weighted sound ratings shown have been calculated per AMCA Standard 301. Values shown are for inlet Lwi(A) sound power level for installation type D - ducted inlet, ducted outlet, rating include the effect of duct end correction.
- dBA levels are not licensed by AMCA International. The AMCA Certified Ratings Seal applies to air performance only.

# TDA 450-V / 12AA/ 5-5/ \_\_ / \_

## 1450rpm - 50Hz

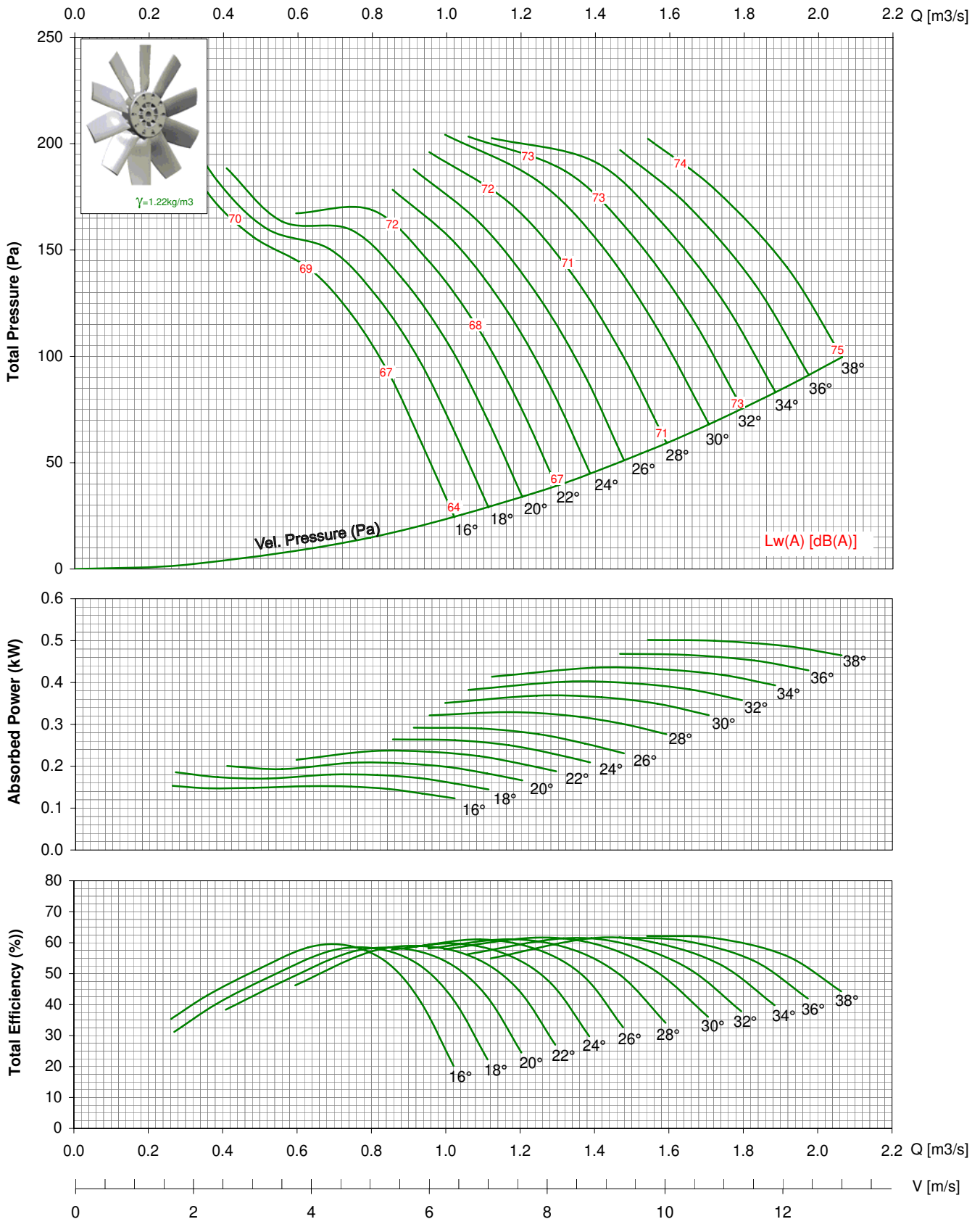

- Performance certified is for installation type D - ducted inlet, ducted outlet. Performance ratings do not include the effects of appurtenances (accessories).
- Power ratings (kW) does not include transmission losses.
- The A-weighted sound ratings shown have been calculated per AMCA Standard 301. Values shown are for inlet Lw(A) sound power level for installation type D - ducted inlet, ducted outlet, rating include the effect of duct end correction.
- The AMCA Certified Ratings Seal applies to air performance only. dBA levels are not licensed by AMCA International.

# TDA 450-V / 12AA/ 5-5/ \_\_ / \_

## 2850rpm - 50Hz

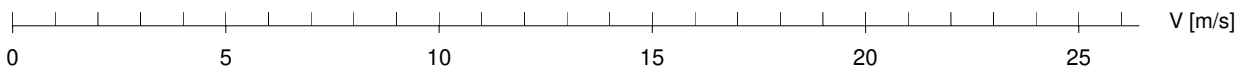
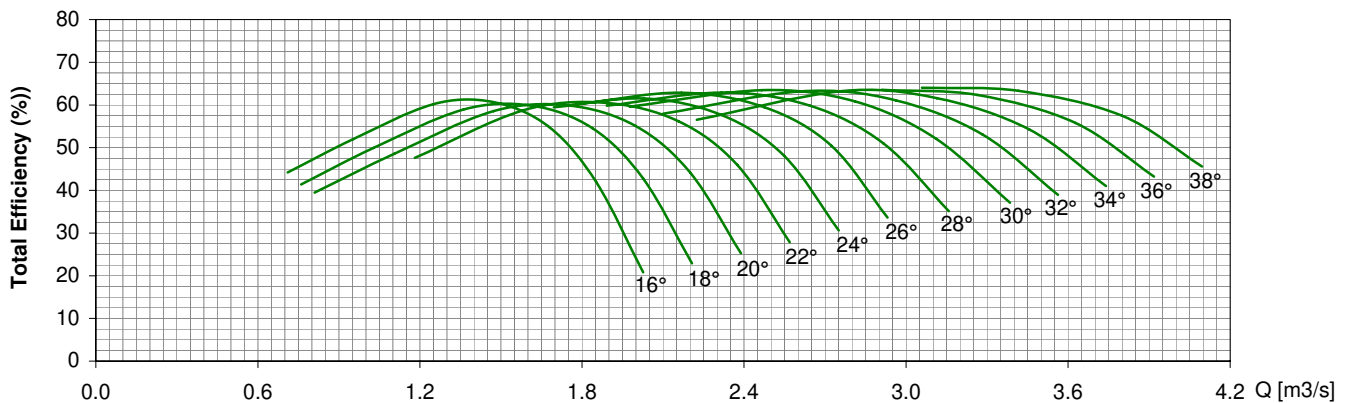
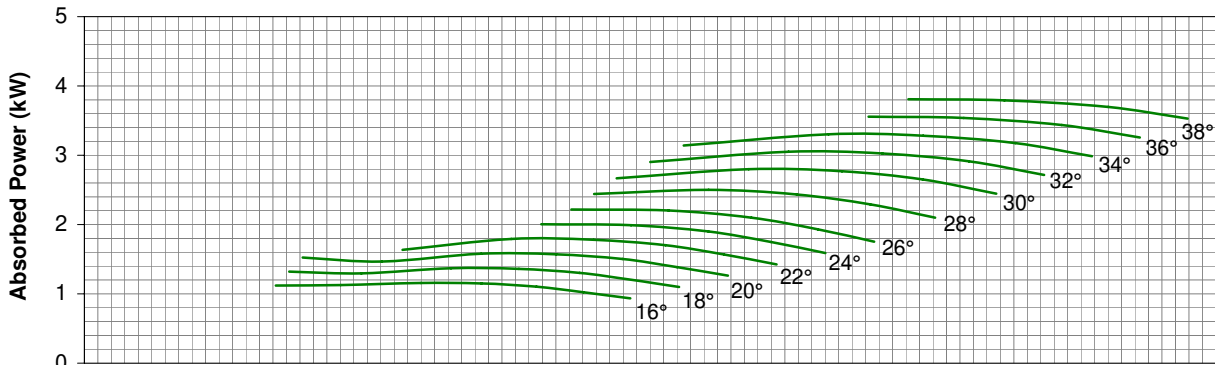
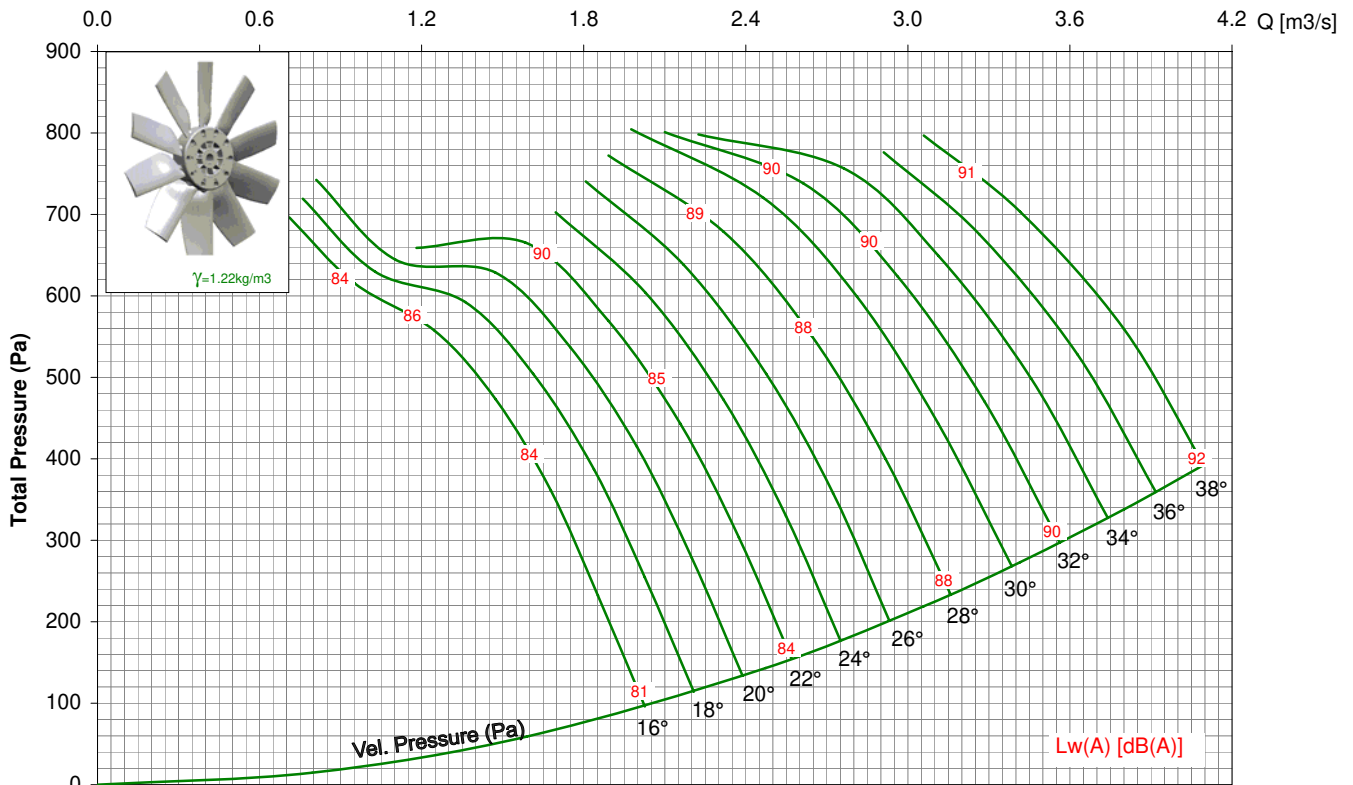

- Performance certified is for installation type D - ducted inlet, ducted outlet. Performance ratings do not include the effects of appurtenances (accessories).
- Power ratings (kW) does not include transmission losses.
- The A-weighted sound ratings shown have been calculated per AMCA Standard 301. Values shown are for inlet Lwi(A) sound power level for installation type D - ducted inlet, ducted outlet, rating include the effect of duct end correction.
- The AMCA Certified Ratings Seal applies to air performance only. dBA levels are not licensed by AMCA International.

# TDA 450-V / 12AA/ 5-5/ \_\_ / \_

## 1150rpm - 60Hz

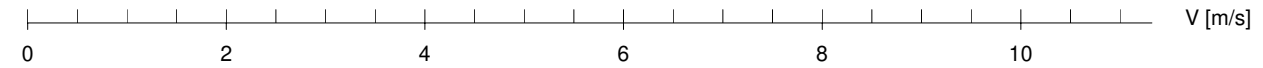
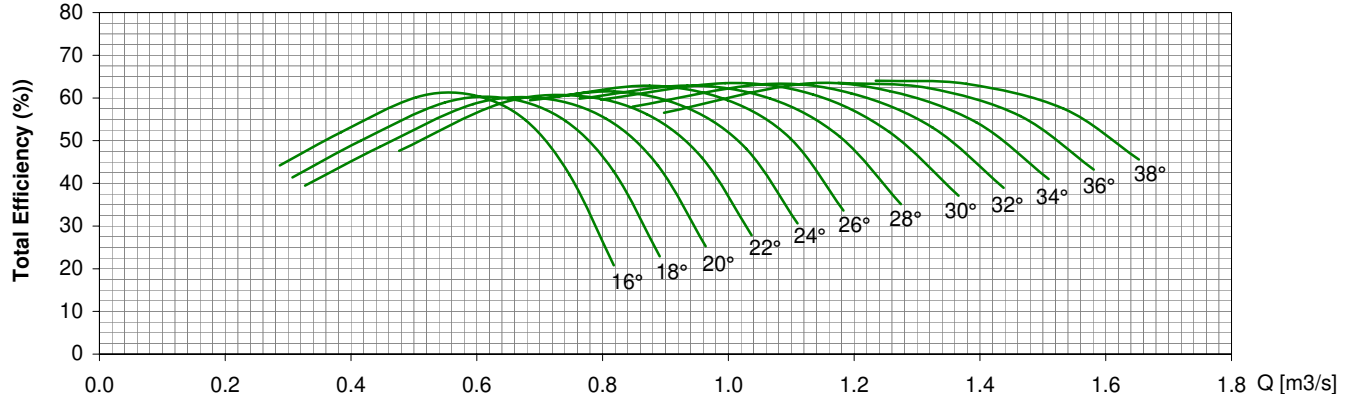
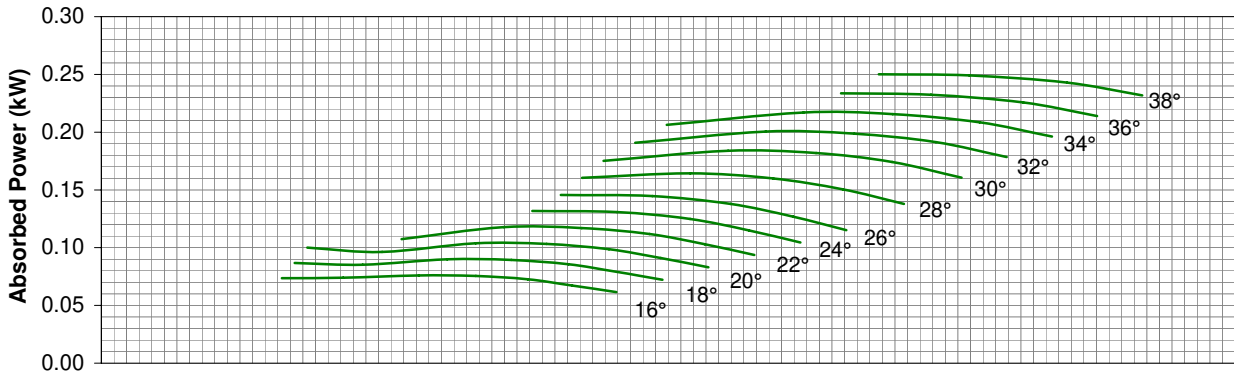
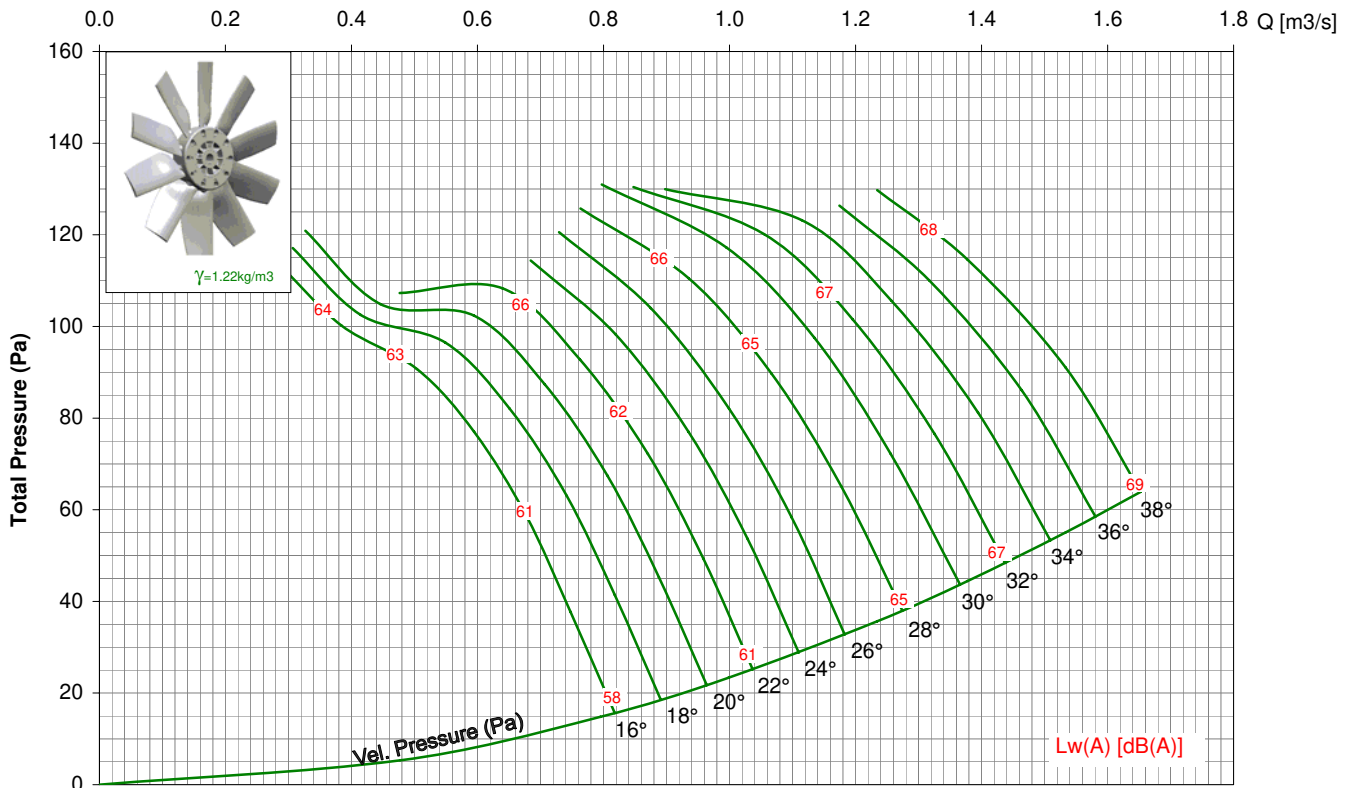

- Performance certified is for installation type D - ducted inlet, ducted outlet. Performance ratings do not include the effects of appurtenances (accessories).
- Power ratings (kW) does not include transmission losses.
- The A-weighted sound ratings shown have been calculated per AMCA Standard 301. Values shown are for inlet Lwi(A) sound power level for installation type D - ducted inlet, ducted outlet, rating include the effect of duct end correction.
- The AMCA Certified Ratings Seal applies to air performance only. dBA levels are not licensed by AMCA International.

# TDA 450-V / 12AA/ 5-5/ \_\_ / \_

## 1750rpm - 60Hz

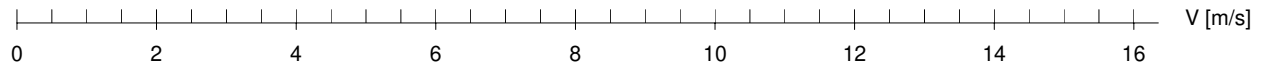
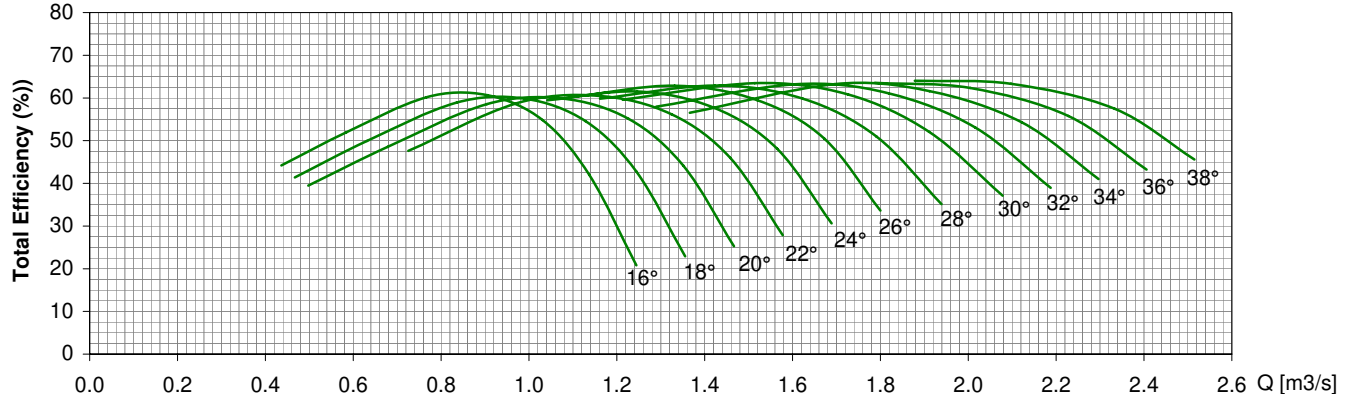
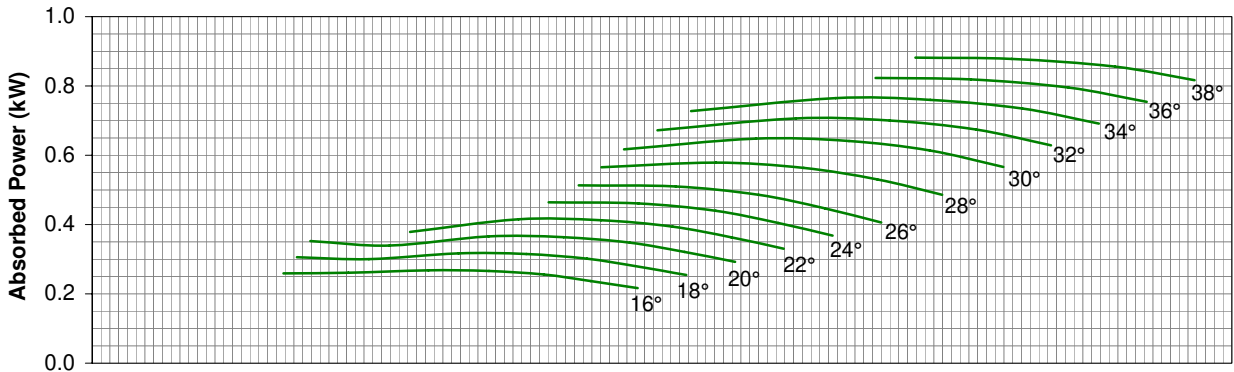
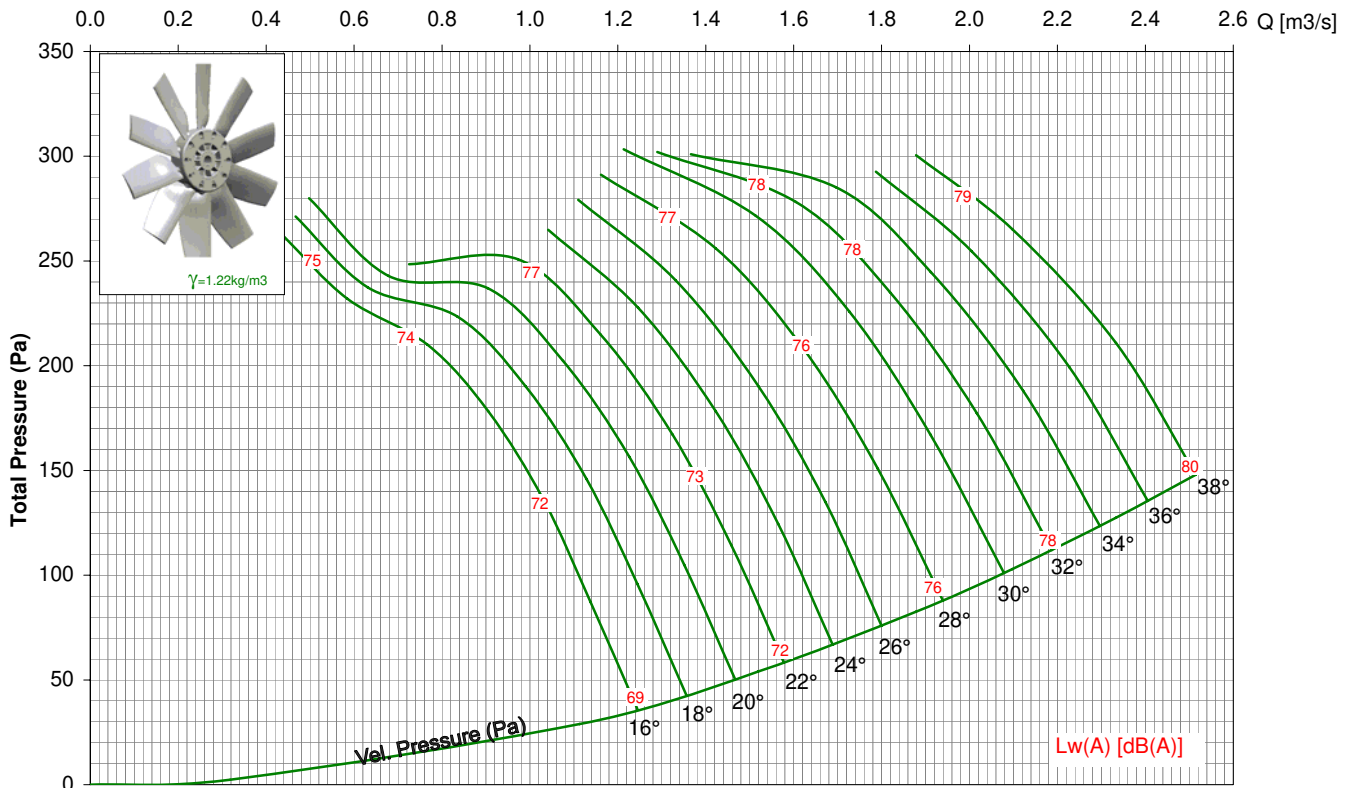

- Performance certified is for installation type D - ducted inlet, ducted outlet. Performance ratings do not include the effects of appurtenances (accessories).
- Power ratings (kW) does not include transmission losses.
- The A-weighted sound ratings shown have been calculated per AMCA Standard 301. Values shown are for inlet Lwi(A) sound power level for installation type D - ducted inlet, ducted outlet, rating include the effect of duct end correction.
- The AMCA Certified Ratings Seal applies to air performance only. dBA levels are not licensed by AMCA International.

# TDA 450-V / 12AA/ 5-5/ \_\_ / \_

## 3450rpm - 60Hz

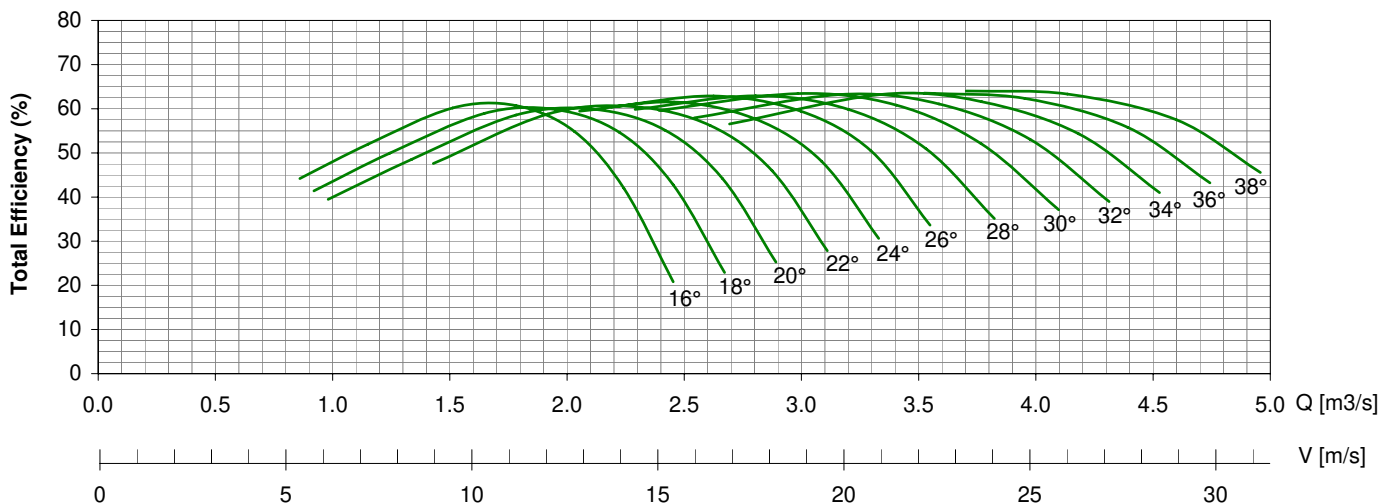
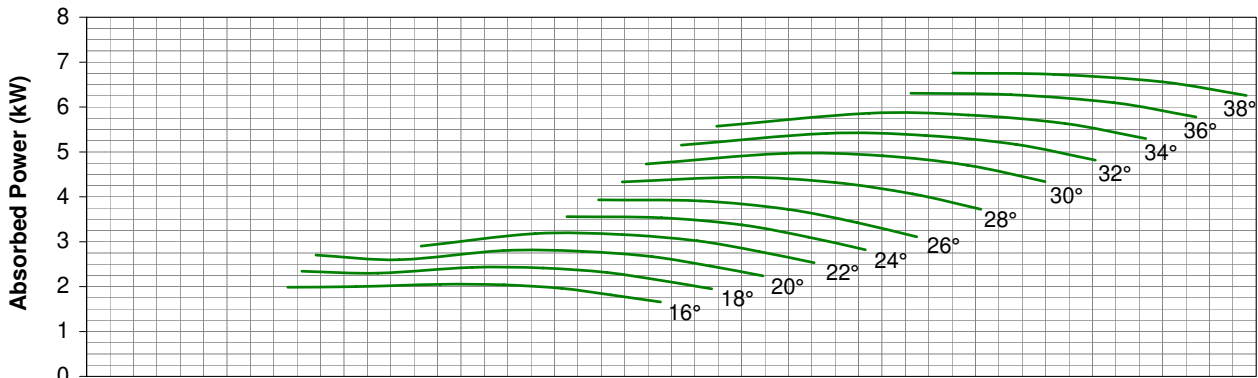
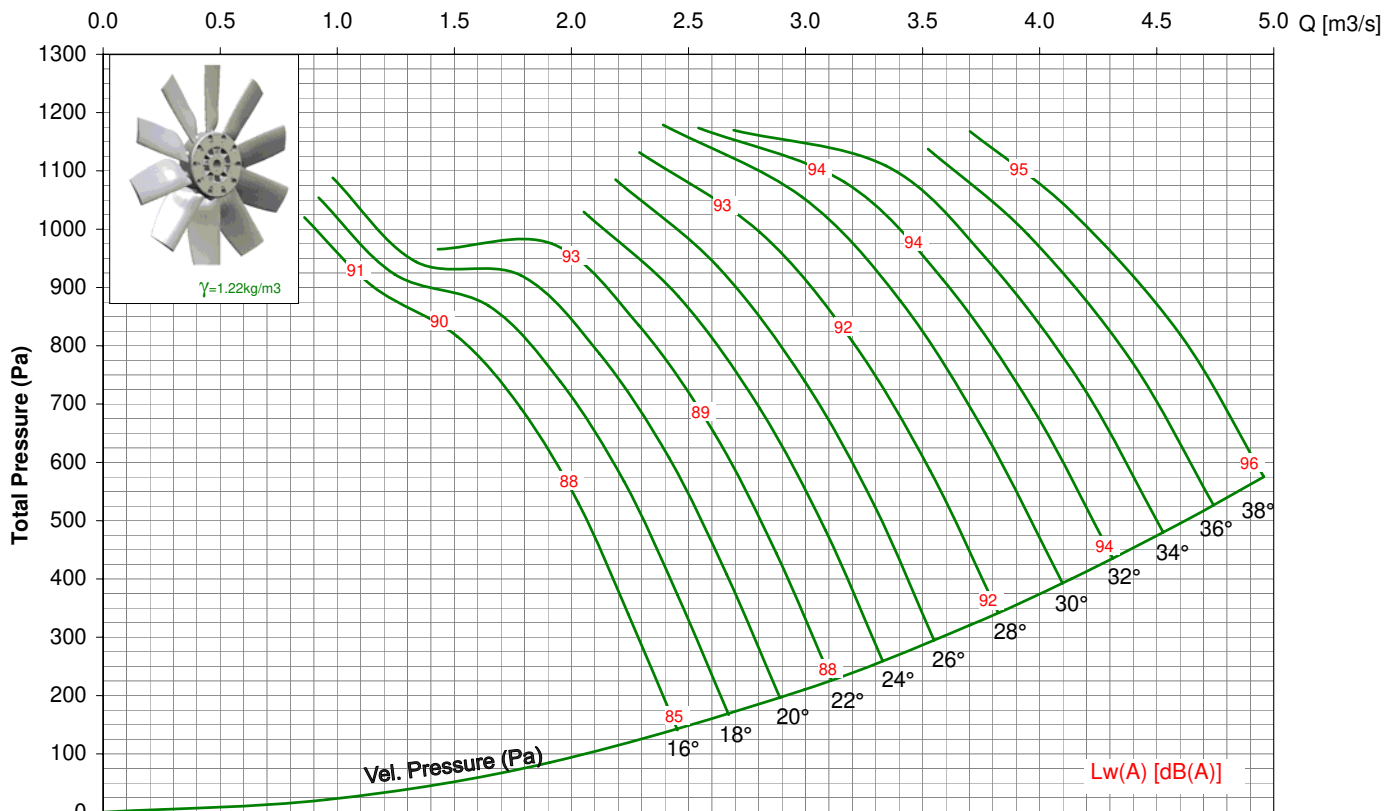

- Performance certified is for installation type D - ducted inlet, ducted outlet. Performance ratings do not include the effects of appurtenances (accessories).
- Power ratings (kW) does not include transmission losses.
- The A-weighted sound ratings shown have been calculated per AMCA Standard 301. Values shown are for inlet Lwi(A) sound power level for installation type D - ducted inlet, ducted outlet, rating include the effect of duct end correction.
- The AMCA Certified Ratings Seal applies to air performance only. dBA levels are not licensed by AMCA International.

# VANE AXIAL FAN DIRECT DRIVEN

## Series TDA-V



### Features

For commercial and industrial applications where large volumes of air are required at moderate to high pressure, special designed integral straightening vanes, reduced turbulence, provide high performance and low sound level.

### Construction

Double flanged casing is produced in mild steel or galvanised Steel, the impeller having manually adjustable pitch aerofoil blades is made of PPG, PAG or pressure-casted Aluminium.

### Finish

Available in standard finishes of galvanisation or painting.

### Operating Temperature

-20°C to +55°C

### Motors

Totally enclosed Class 'F' motor, to a min. IP54 protection are fitted as standard. Standard motor up to 2.2kW are usually supplied on DOL starting, motor 3.0kW and above are star/delta starting.

### Airflow Direction

Air flowing from impeller to motor is fitted as standard.



Kruger\* certifies that the TDA 500 -V shown herein is licensed to bear the AMCA Seal. The ratings shown are based on tests and procedures performed in accordance with AMCA publication 211 and comply with the requirements of the AMCA Certified Ratings Program.

- \*Kruger Ventilation Industries Asia Co., Ltd
- \*Guangzhou Kruger Ventilation Co., Ltd
- \*Kruger Ventilation (Taiwan) Co., Ltd
- \*Kruger Ventilation Industries (Vietnam) Co., Ltd
- \*Kruger Ventilation Industries (India) Pvt. Ltd
- \*Kruger Ventilation Industries (North India) Pvt. Ltd
- \*Kruger Ventilation Industries (Thailand) Co., Ltd
- \*Kruvent Industries (M) Sdn. Bhd
- \*P.T. Kruger Ventilation Indonesia
- \*Shanghai Kruger Ventilation Co., Ltd
- \*Wuhan Kruger Ventilation Co., Ltd

**MODEL: TDA 500-V / 12AA / 9-9 / \_ / \_**

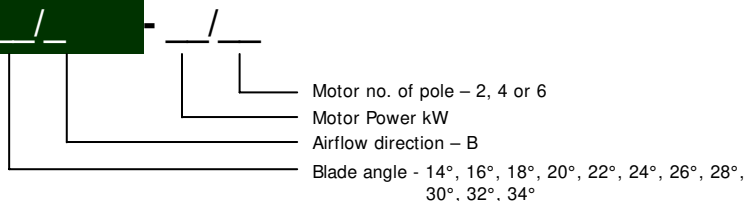

\* All Dimension in mm

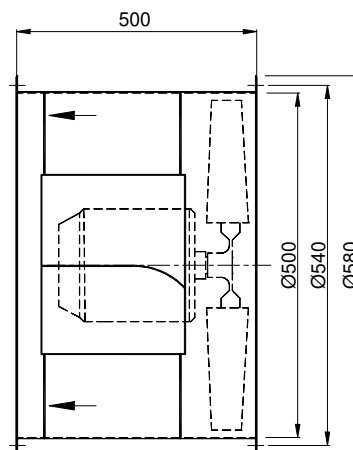
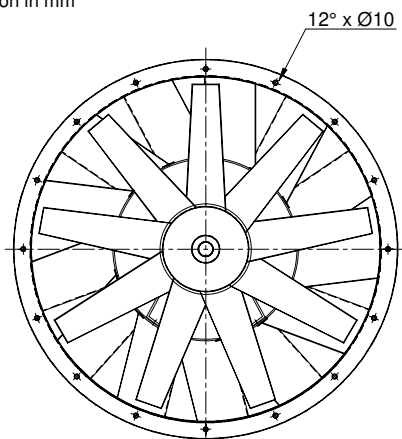

# TDA 500-V / 12AA/ 9-9/ \_\_ / \_ 950rpm - 50Hz

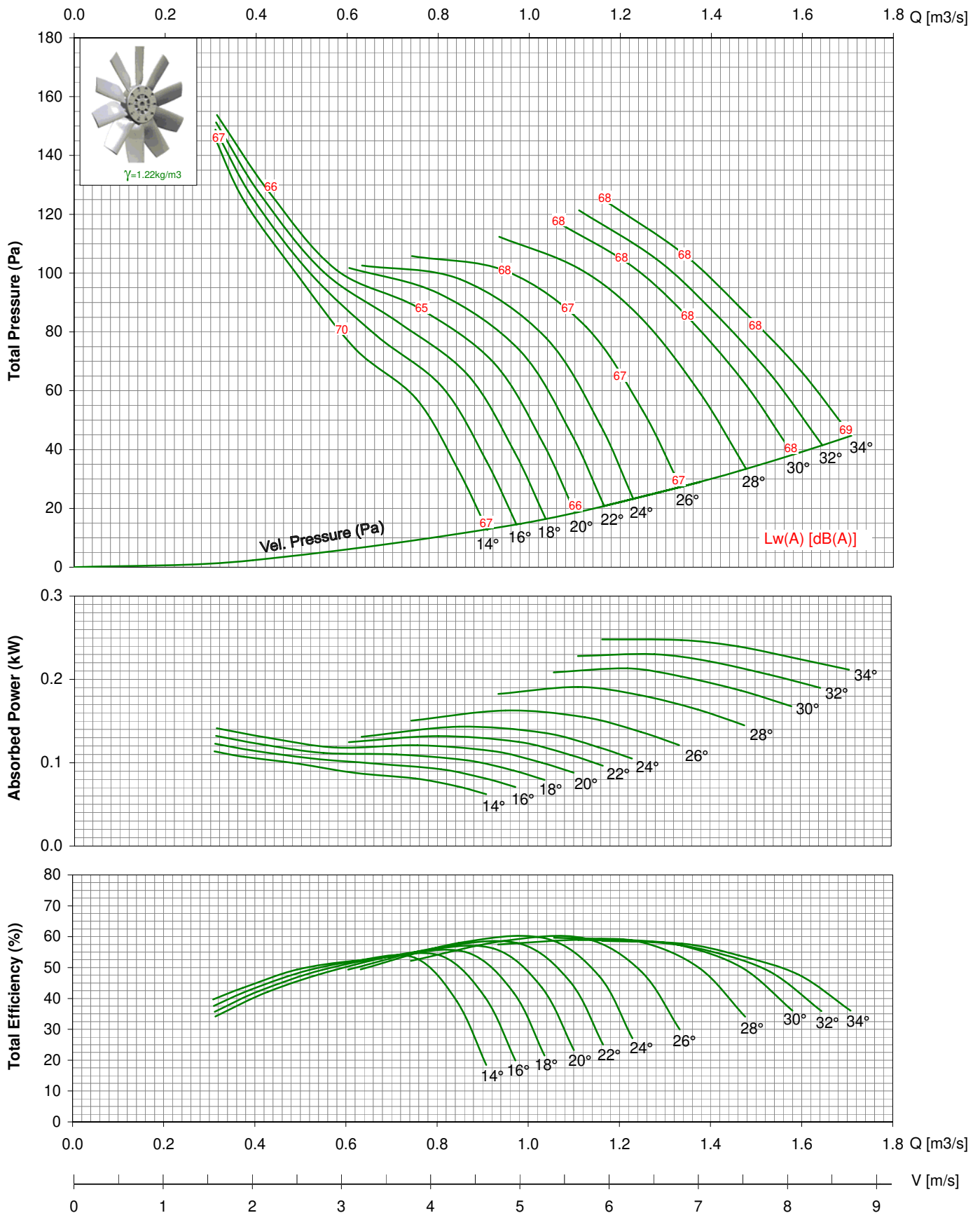

- Performance certified is for installation type D - ducted inlet, ducted outlet. Performance ratings do not include the effects of appurtenances (accessories).

- Power ratings (kW) does not include transmission losses.

- The A-weighted sound ratings shown have been calculated per AMCA Standard 301. Values shown are for inlet Lwi(A) sound power level for installation type D - ducted inlet, ducted outlet, rating include the effect of duct end correction.

- The AMCA Certified Ratings Seal applies to air performance only. dBA levels are not licensed by AMCA international.

# TDA 500-V / 12AA/ 9-9/ \_\_ / \_ 1450rpm - 50Hz

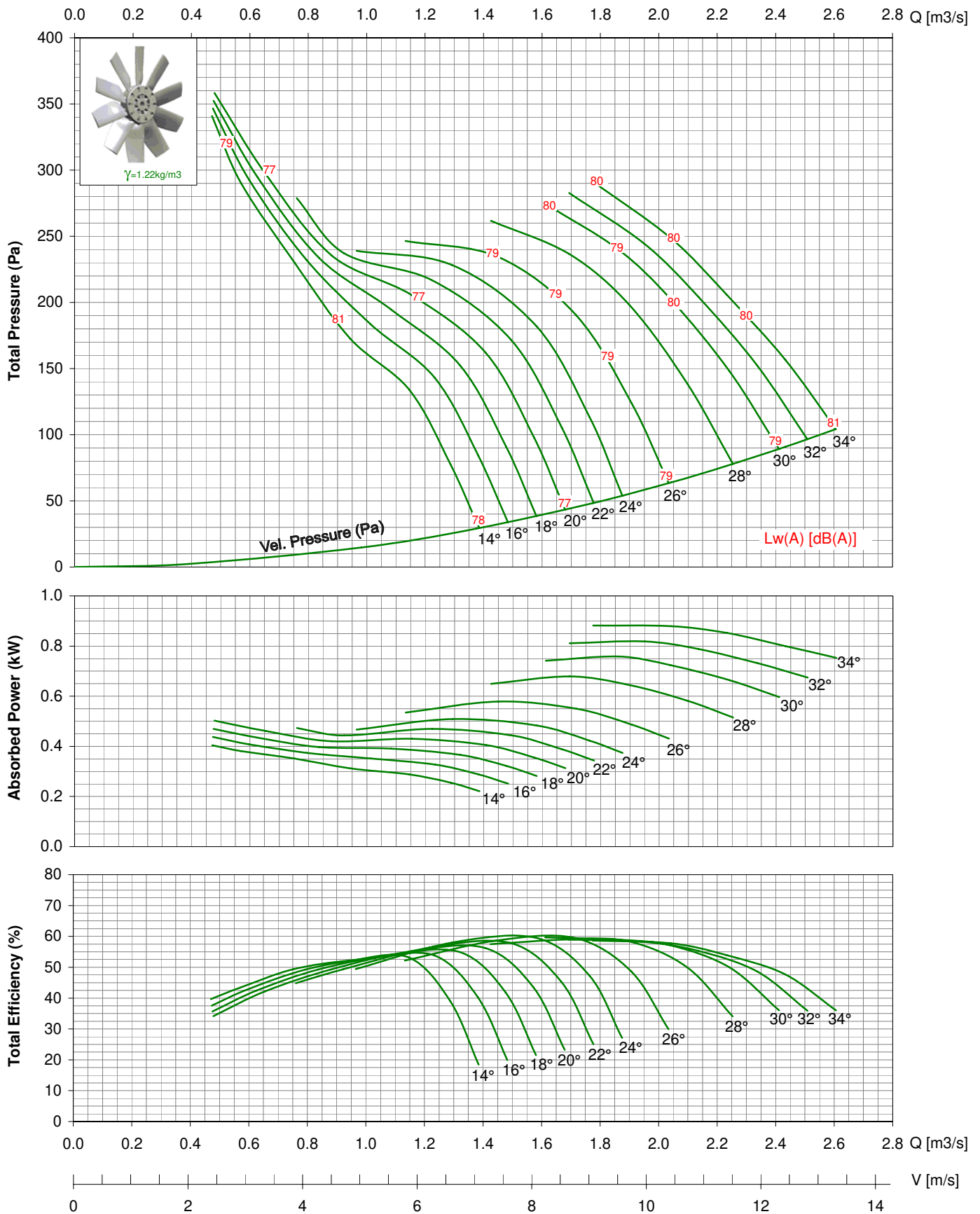

- Performance certified for installation type D - ducted inlet, ducted outlet. Performance ratings do not include the effects of appurtenances (accessories).

- Power ratings (kW) does not include transmission losses.

- The A-weighted sound ratings shown have been calculated per AMCA Standard 301. Values shown are for inlet  $L_{wi}(A)$  sound power level for installation type D - ducted inlet, ducted outlet, rating include the effect of duct end correction.

- The AMCA Certified Ratings Seal applies to air performance only. dBA levels are not licensed by AMCA international.

# TDA 500-V / 12AA/ 9-9/ \_\_ / \_ 2850rpm - 50Hz

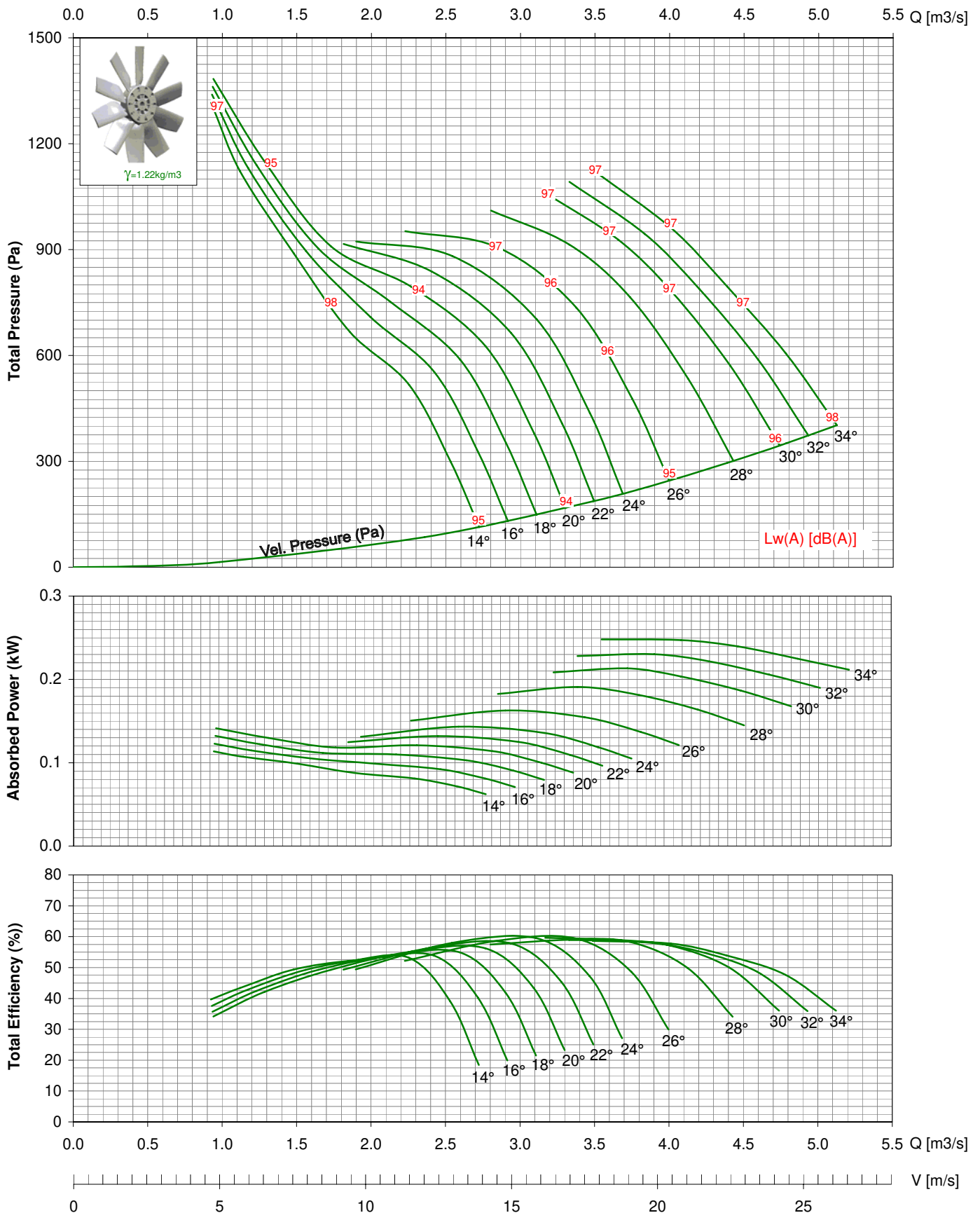

- Performance certified for installation type D - ducted inlet, ducted outlet. Performance ratings do not include the effects of appurtenances (accessories).
- Power ratings (kW) does not include transmission losses.
- The A-weighted sound ratings shown have been calculated per AMCA Standard 301. Values shown are for inlet Lwi(A) sound power level for installation type D - ducted inlet, ducted outlet, rating include the effect of duct end correction.
- The AMCA Certified Ratings Seal applies to air performance only. dBA levels are not licensed by AMCA international.

# TDA 500-V / 12AA/ 9-9/ \_\_ / \_

## 1150rpm - 60Hz

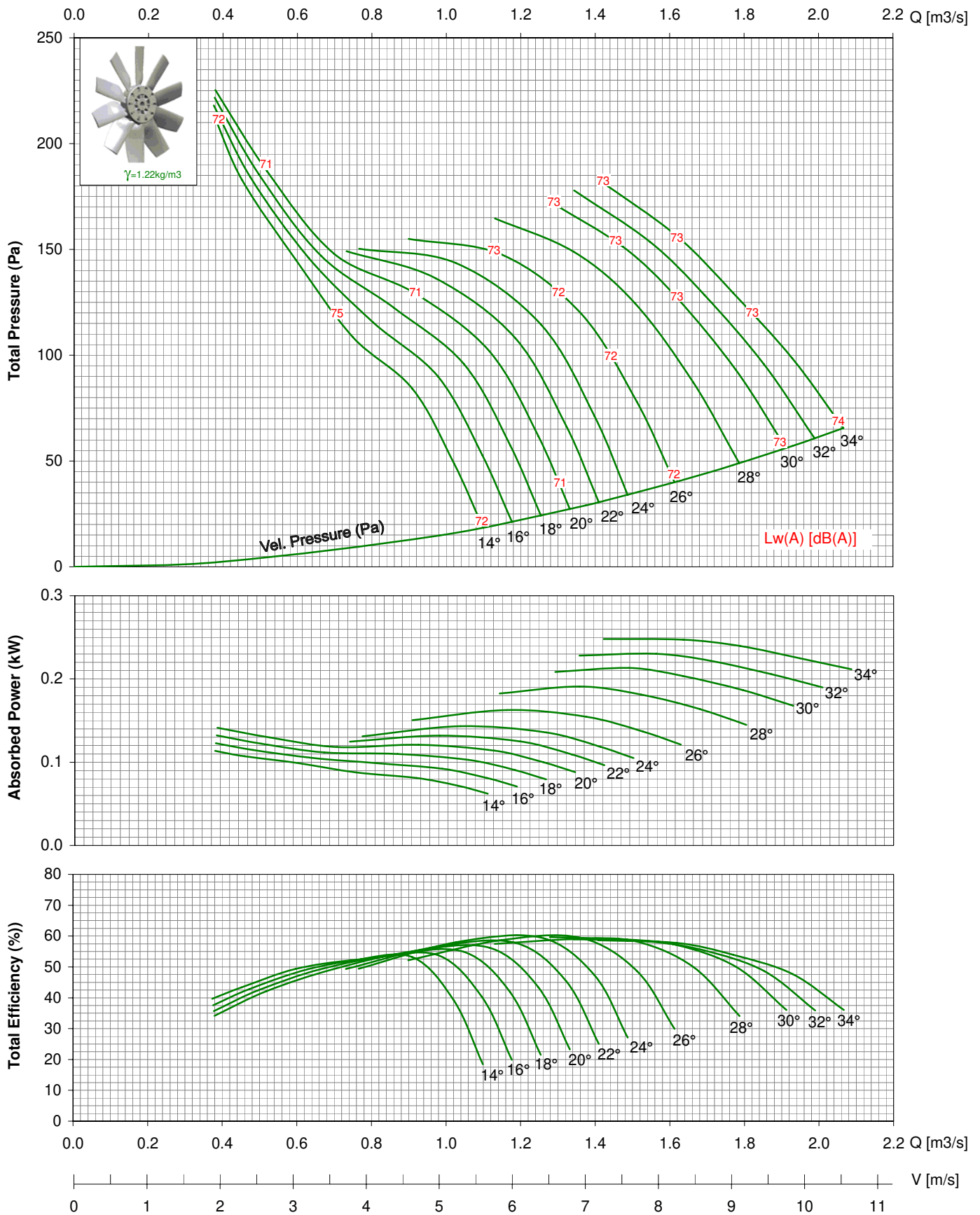

- Performance certified is for installation type D - ducted inlet, ducted outlet. Performance ratings do not include the effects of appurtenances (accessories).
- Power ratings (kW) does not include transmission losses.
- The A-weighted sound ratings shown have been calculated per AMCA Standard 301. Values shown are for inlet  $L_{wi}(A)$  sound power level for installation type D - ducted inlet, ducted outlet, rating include the effect of duct end correction.
- The AMCA Certified Ratings Seal applies to air performance only. dBA levels are not licensed by AMCA international.

# TDA 500-V / 12AA/ 9-9/ \_\_ / \_ 1750rpm - 60Hz

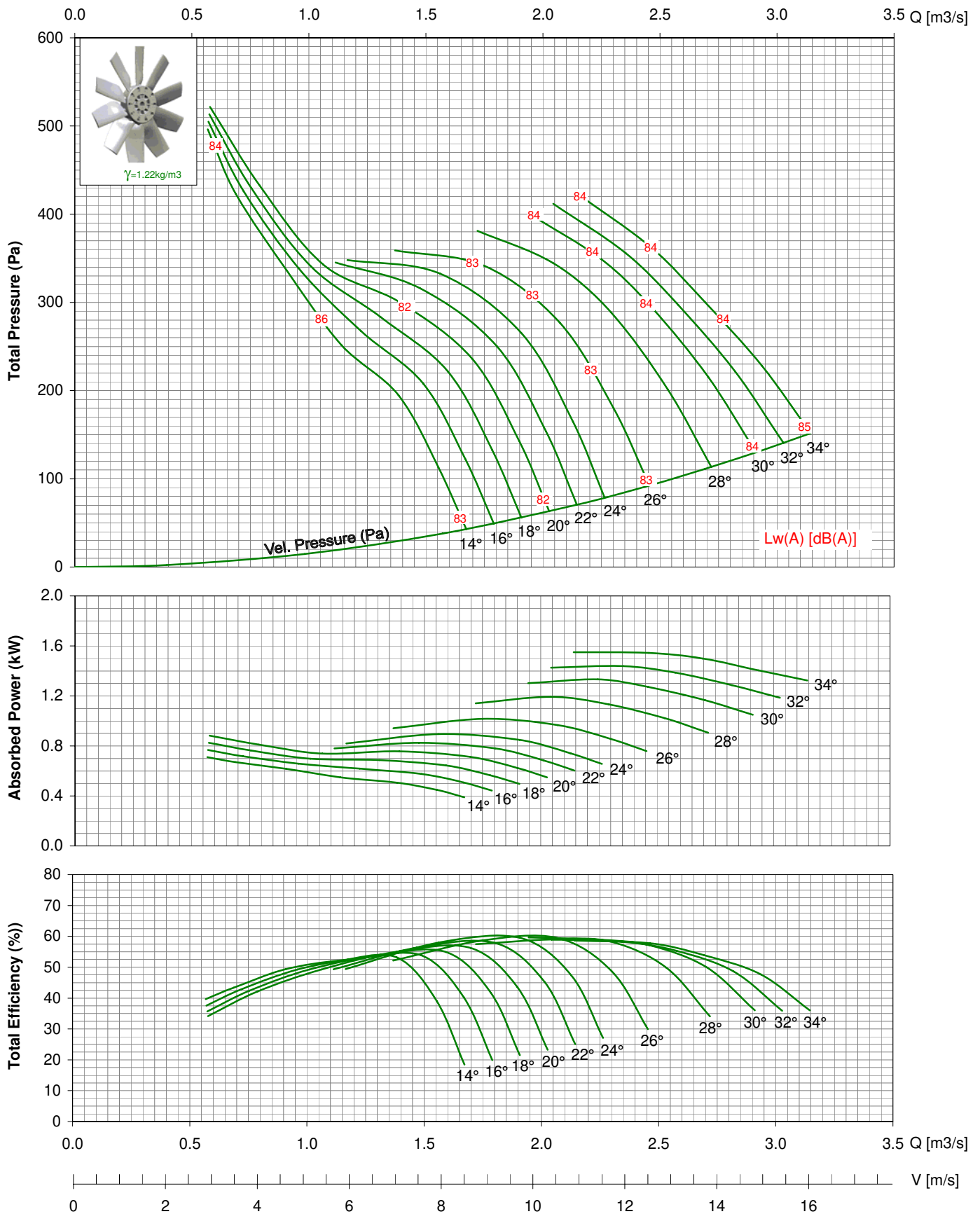

- Performance certified is for installation type D - ducted inlet, ducted outlet. Performance ratings do not include the effects of appurtenances (accessories).
- Power ratings (KW) does not include transmission losses.
- The A-weighted sound ratings shown have been calculated per AMCA Standard 301. Values shown are for inlet  $L_{wi}(A)$  sound power level for installation type D - ducted inlet, ducted outlet, rating include the effect of duct end correction.
- The AMCA Certified Ratings Seal applies to air performance only. dBA levels are not licensed by AMCA international.



# VANE AXIAL FAN DIRECT DRIVEN

## Series TDA-V



### Features

For commercial and industrial applications where large volumes of air are required at moderate to high pressure, special designed integral straightening vanes, reduced turbulence, provide high performance and low sound level.

### Construction

Double flanged casing is produced in mild steel or galvanised Steel, the impeller having manually adjustable pitch aerofoil blades is made of PPG, PAG or pressure-casted Aluminium.

### Finish

Available in standard finishes of galvanisation or painting.

### Operating Temperature

-20°C to +55°C

### Motors

Totally enclosed Class 'F' motor, to a min. IP54 protection are fitted as standard. Standard motor up to 2.2kW are usually supplied on DOL starting, motor 3.0kW and above are star/delta starting.

### Airflow Direction

Air flowing from impeller to motor is fitted as standard.



Kruger\* certifies that the TDA 560 -V shown herein is licensed to bear the AMCA Seal. The ratings shown are based on tests and procedures performed in accordance with AMCA publication 211 and comply with the requirements of the AMCA Certified Ratings Program.

- \*Kruger Ventilation Industries Asia Co., Ltd
- \*Guangzhou Kruger Ventilation Co., Ltd
- \*Kruger Ventilation (Taiwan) Co., Ltd
- \*Kruger Ventilation Industries (Vietnam) Co., Ltd
- \*Kruger Ventilation Industries (India) Pvt. Ltd
- \*Kruger Ventilation Industries (North India) Pvt. Ltd
- \*Kruger Ventilation Industries (Thailand) Co., Ltd
- \*Kruvent Industries (M) Sdn. Bhd
- \*P.T. Kruger Ventilation Indonesia
- \*Shanghai Kruger Ventilation Co., Ltd
- \*Wuhan Kruger Ventilation Co., Ltd

**MODEL: TDA 560-V / 12AA / 9-9 / \_ / \_**

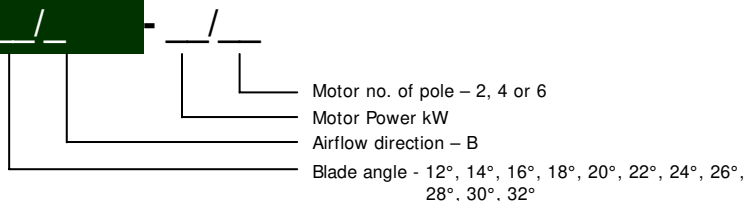

\* All Dimension in mm

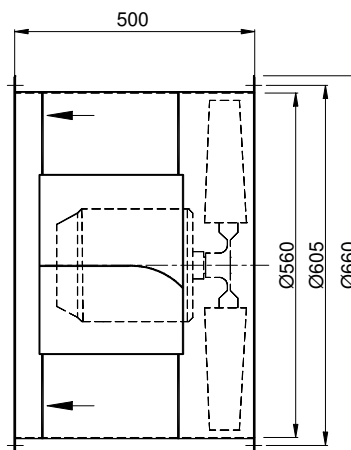
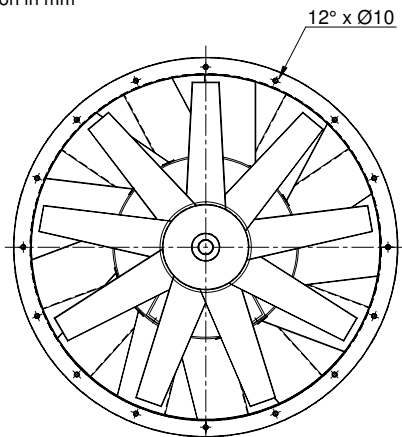

# TDA 560-V / 12AA/ 9-9/ \_\_ / \_ 950rpm - 50Hz

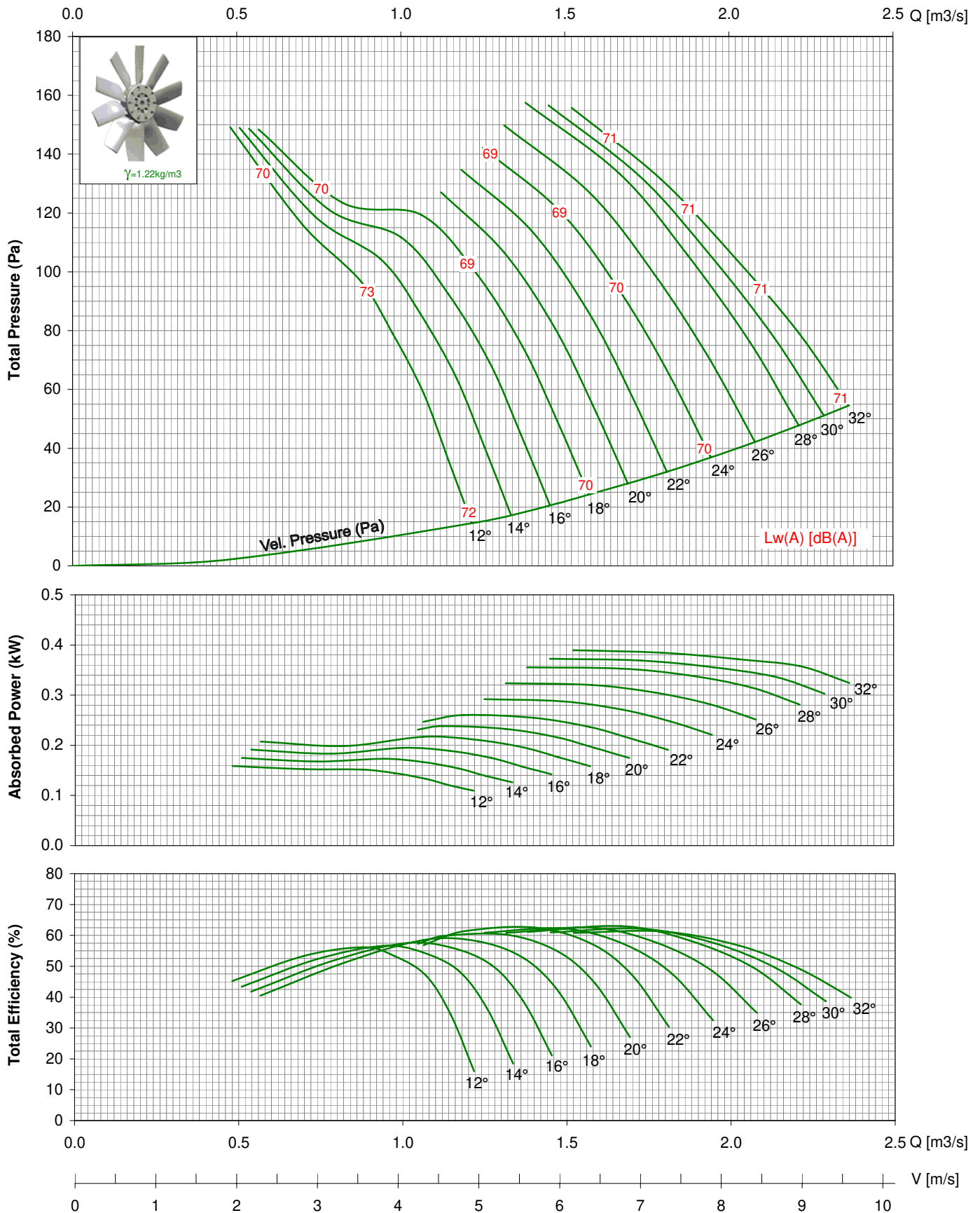

- Performance certified is for installation type D - ducted inlet, ducted outlet. Performance ratings do not include the effects of appurtenances (accessories).  
 - Power ratings (kW) does not include transmission losses.  
 - The A-weighted sound ratings shown have been calculated per AMCA Standard 301. Values shown are for inlet Lwi(A) sound power level for installation type D - ducted inlet, ducted outlet, rating include the effect of duct end correction.  
 - The AMCA Certified Ratings Seal applies to air performance only. dBA levels are not licensed by AMCA international.

# TDA 560-V / 12AA/ 9-9/ \_\_ / \_ 1450rpm - 50Hz

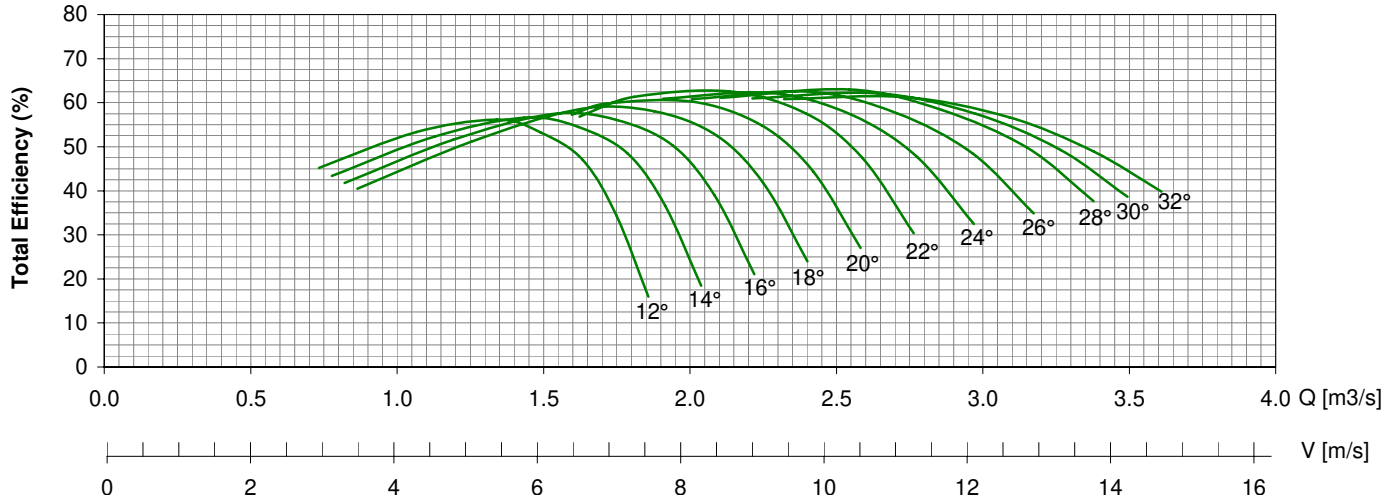
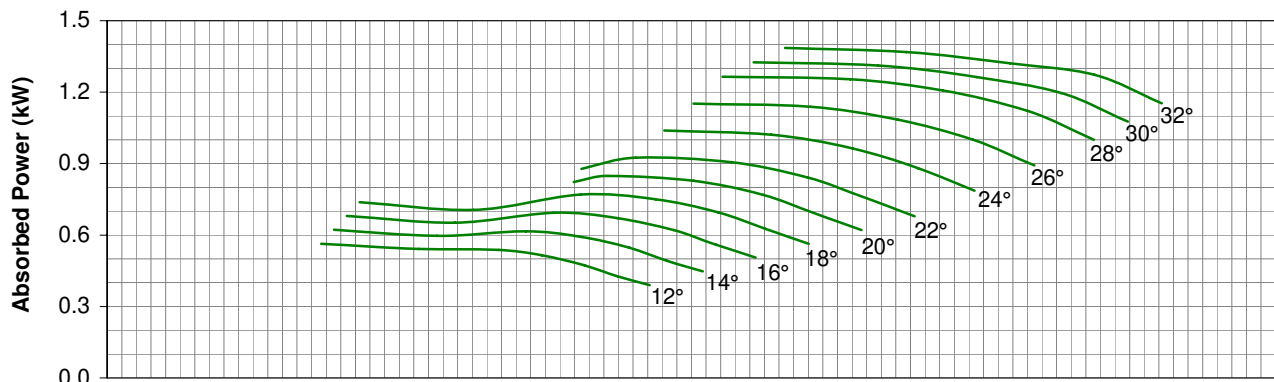
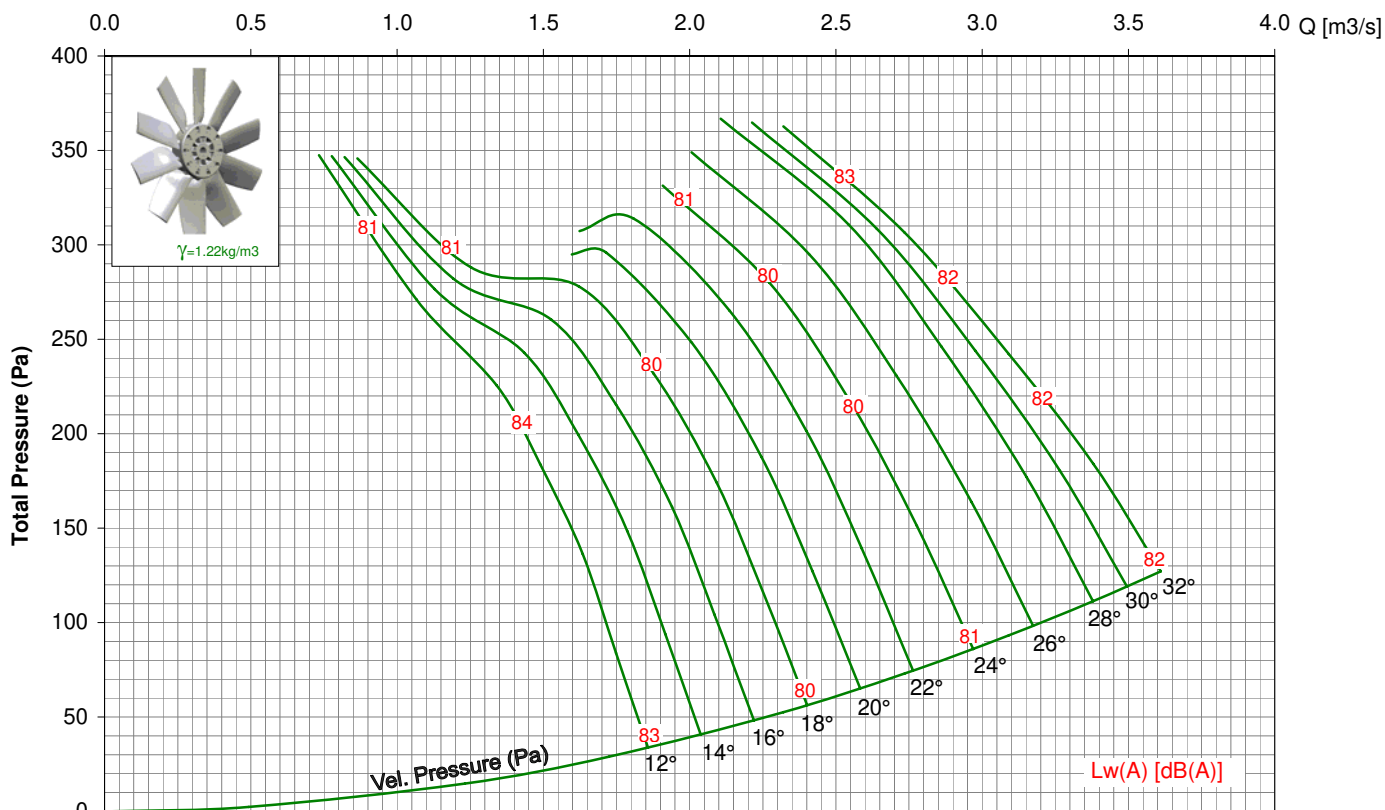

- Performance certified is for installation type D - ducted inlet, ducted outlet. Performance ratings do not include the effects of appurtenances (accessories).
- Power ratings (kW) does not include transmission losses.
- The A-weighted sound ratings shown have been calculated per AMCA Standard 301. Values shown are for inlet Lwi(A) sound power level for installation type D - ducted inlet, ducted outlet, rating include the effect of duct end correction.
- The AMCA Certified Ratings Seal applies to air performance only. dBA levels are not licensed by AMCA international.

# TDA 560-V / 12AA/ 9-9/ \_\_ / \_ 2850rpm - 50Hz

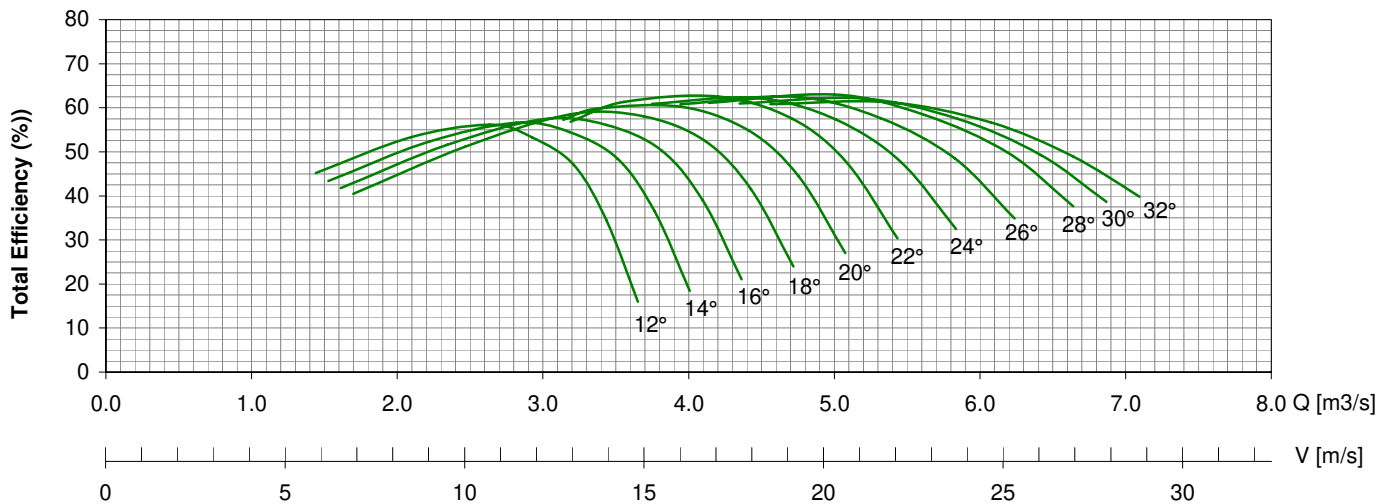
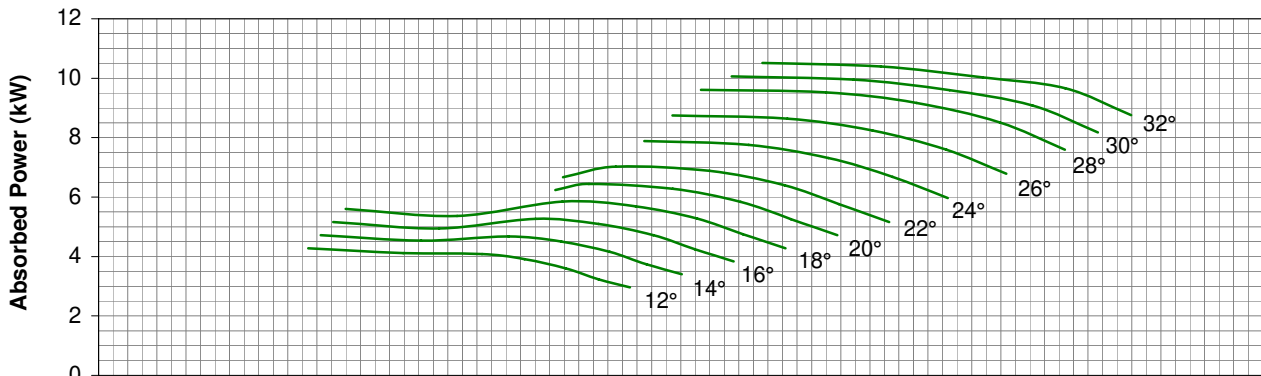
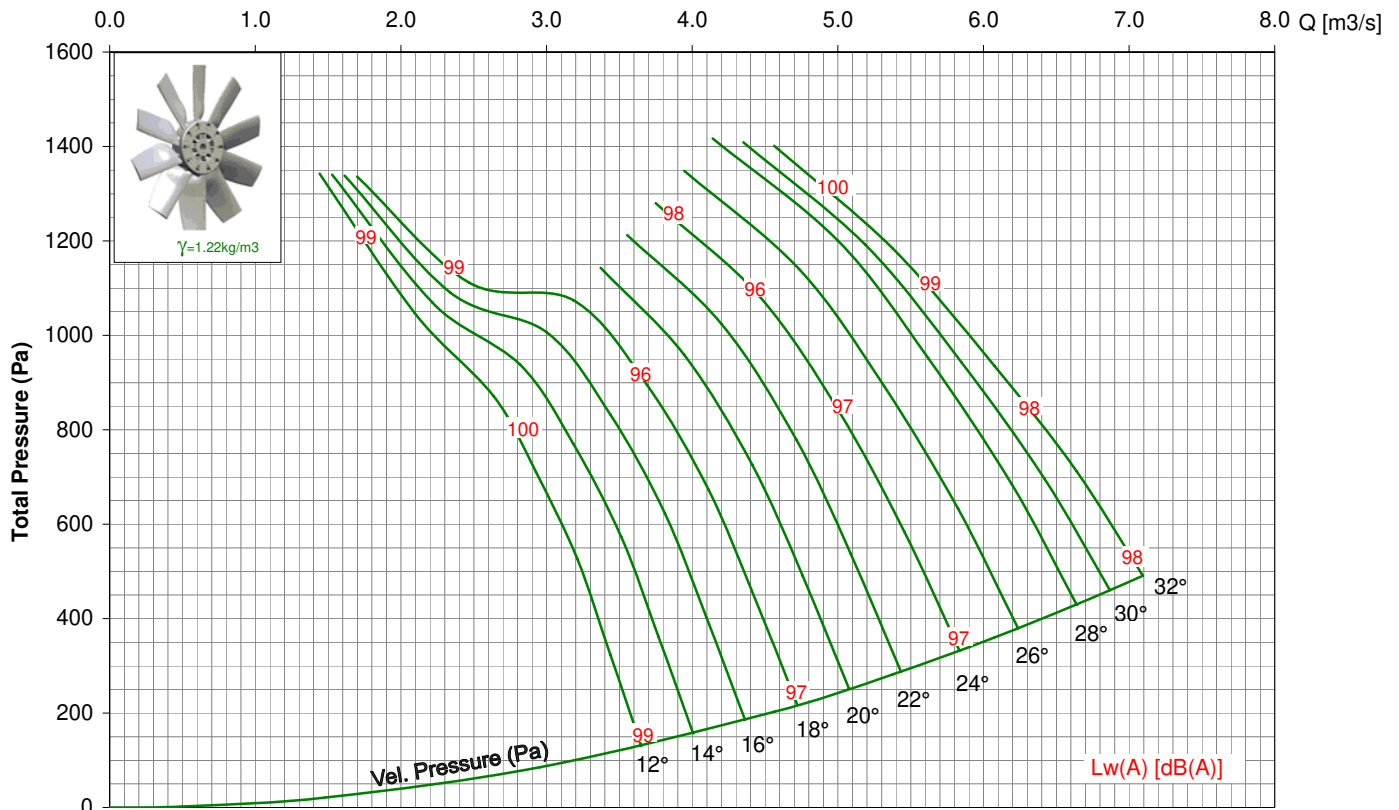

- Performance certified is for installation type D - ducted inlet, ducted outlet. Performance ratings do not include the effects of appurtenances (accessories).
- Power ratings (kW) does not include transmission losses.
- The A-weighted sound ratings shown have been calculated per AMCA Standard 301. Values shown are for inlet Lwi(A) sound power level for installation type D - ducted inlet, ducted outlet, rating include the effect of duct end correction.
- The AMCA Certified Ratings Seal applies to air performance only. dBA levels are not licensed by AMCA international.

# TDA 560-V / 12AA/ 9-9/ \_\_ / \_ 1150rpm - 60Hz

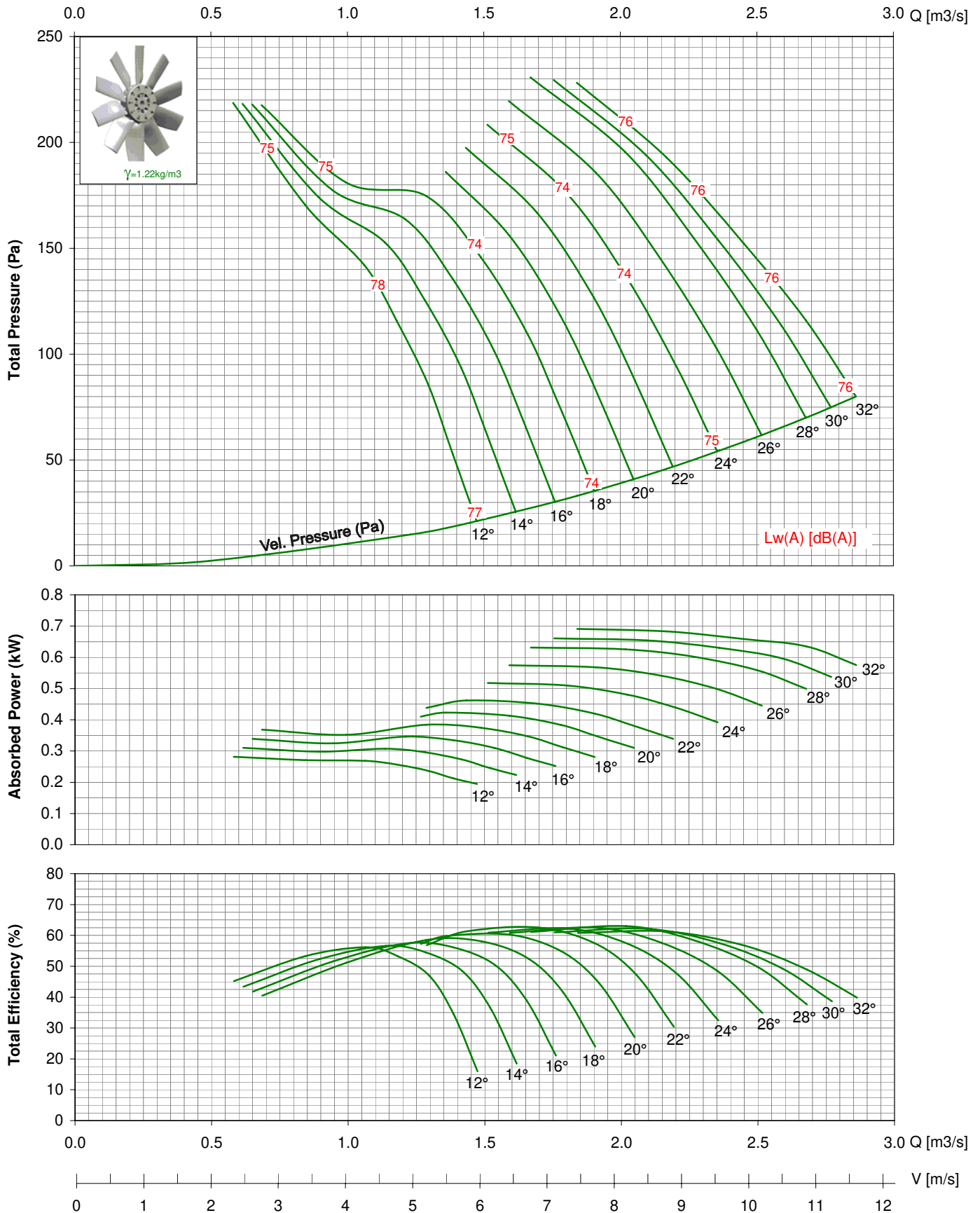

- Performance certified for installation type D - ducted inlet, ducted outlet. Performance ratings do not include the effects of appurtenances (accessories).

- Power ratings (kW) does not include transmission losses.

- The A-weighted sound ratings shown have been calculated per AMCA Standard 301. Values shown are for inlet Lw(A) sound power level for installation type D - ducted inlet, ducted outlet, rating include the effect of duct end correction.

- The AMCA Certified Ratings Seal applies to air performance only. dBA levels are not licensed by AMCA international.

# TDA 560-V / 12AA/ 9-9/ \_\_ / \_ 1750rpm - 60Hz

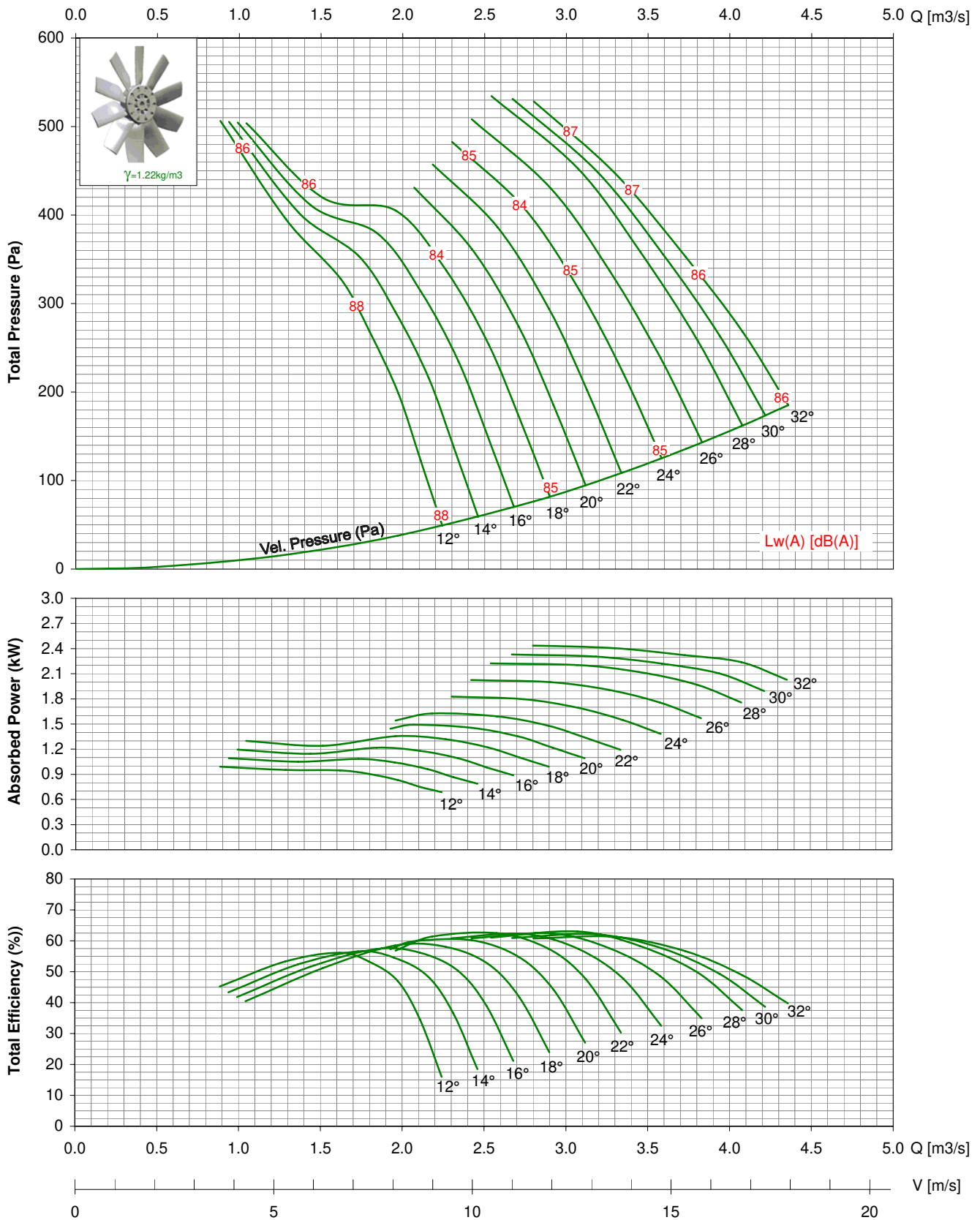

- Performance certified is for installation type D - ducted inlet, ducted outlet. Performance ratings do not include the effects of appurtenances (accessories).
- Power ratings (kW) does not include transmission losses.
- The A-weighted sound ratings shown have been calculated per AMCA Standard 301. Values shown are for inlet  $L_{wi}(A)$  sound power level for installation type D - ducted inlet, ducted outlet, rating include the effect of duct end correction.
- The AMCA Certified Ratings Seal applies to air performance only. dBA levels are not licensed by AMCA international.

# VANE AXIAL FAN DIRECT DRIVEN

## Series TDA-V



### Features

For commercial and industrial applications where large volumes of air are required at moderate to high pressure, special designed integral straightening vanes, reduced turbulence, provide high performance and low sound level.

### Construction

Double flanged casing is produced in mild steel or galvanised Steel, the impeller having manually adjustable pitch aerofoil blades is made of PPG, PAG or pressure-casted Aluminium.

### Finish

Available in standard finishes of galvanisation or painting.

### Operating Temperature

-20°C to +55°C

### Motors

Totally enclosed Class 'F' motor, to a min. IP54 protection are fitted as standard. Standard motor up to 2.2kW are usually supplied on DOL starting, motor 3.0kW and above are star/delta starting.

### Airflow Direction

Air flowing from impeller to motor is fitted as standard.



Kruger\* certifies that the TDA 630 -V shown herein is licensed to bear the AMCA Seal. The ratings shown are based on tests and procedures performed in accordance with AMCA publication 211 and comply with the requirements of the AMCA Certified Ratings Program.

- \*Kruger Ventilation Industries Asia Co., Ltd
- \*Guangzhou Kruger Ventilation Co., Ltd
- \*Kruger Ventilation (Taiwan) Co., Ltd
- \*Kruger Ventilation Industries (Vietnam) Co., Ltd
- \*Kruger Ventilation Industries (India) Pvt. Ltd
- \*Kruger Ventilation Industries (North India) Pvt. Ltd
- \*Kruger Ventilation Industries (Thailand) Co., Ltd
- \*Kruvent Industries (M) Sdn. Bhd
- \*P.T. Kruger Ventilation Indonesia
- \*Shanghai Kruger Ventilation Co., Ltd
- \*Wuhan Kruger Ventilation Co., Ltd

## MODEL: TDA 630-V / 12AA / 12-12 / \_ / \_

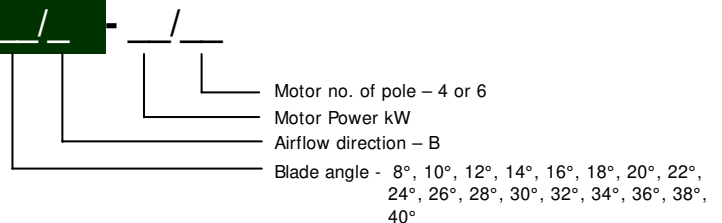

\* All Dimension in mm

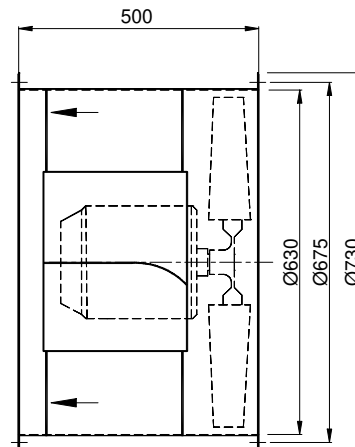
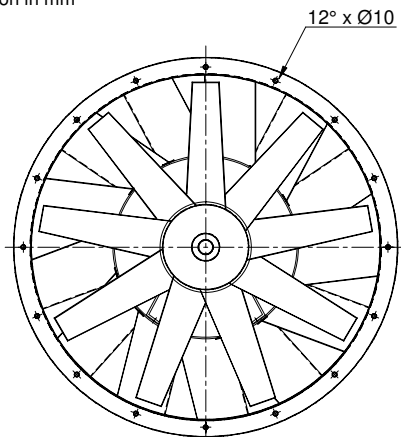

# TDA 630-V / 12AA/ 12-12/ \_\_ / \_ 950rpm - 50Hz

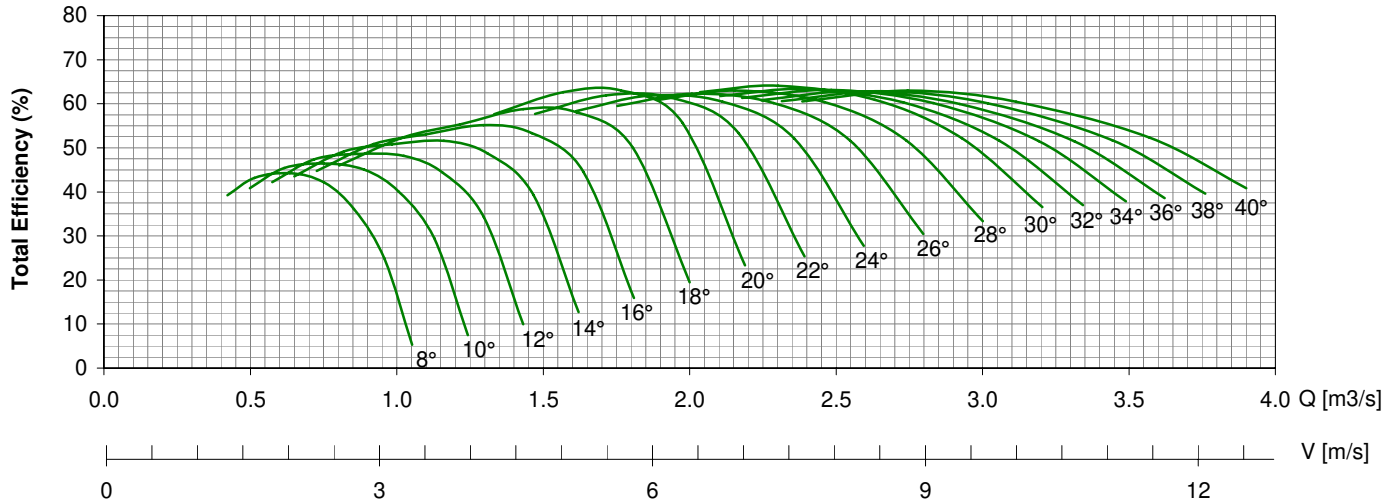
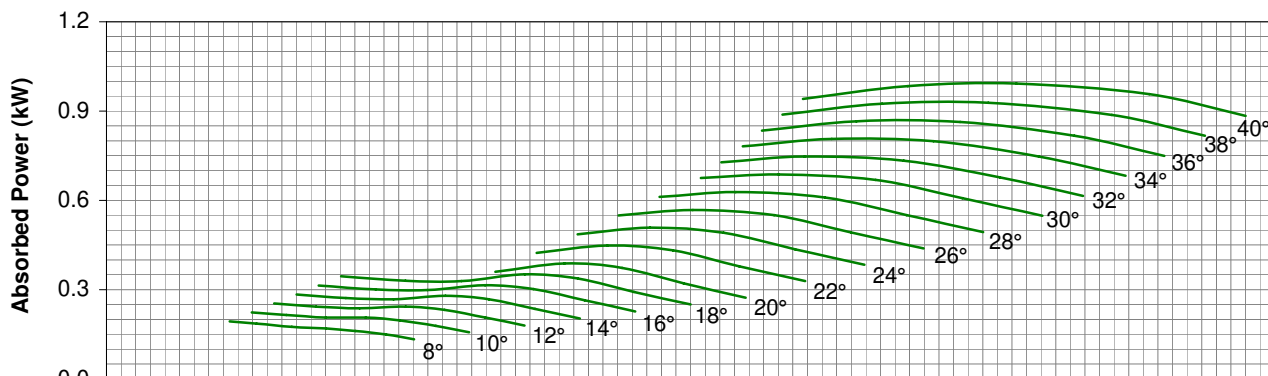
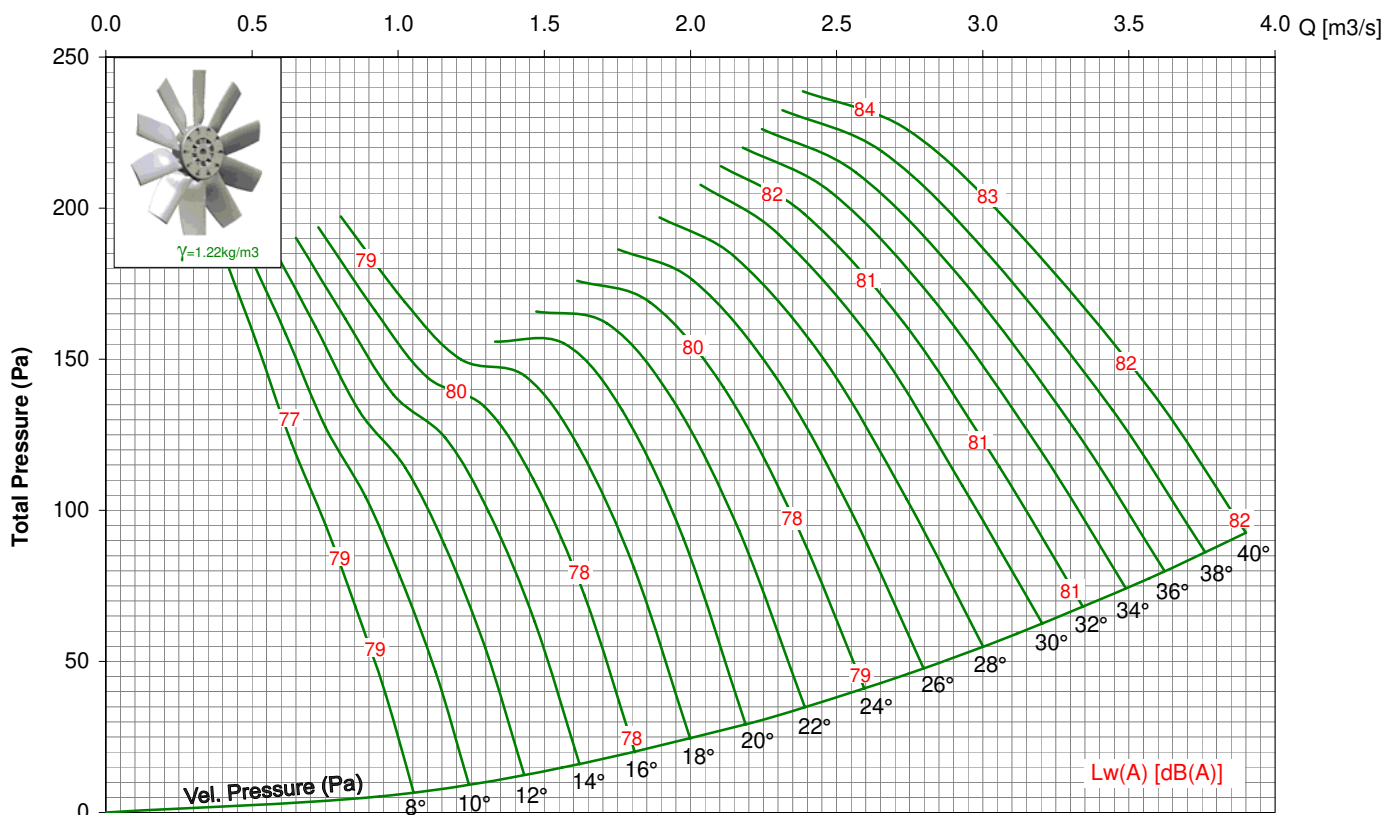

- Performance certified is for installation type D - ducted inlet, ducted outlet. Performance ratings do not include the effects of appurtenances (accessories).

- Power ratings (kW) does not include transmission losses.

- The A-weighted sound ratings shown have been calculated per AMCA Standard 301. Values shown are for inlet Lwi(A) sound power level for installation type D - ducted inlet, ducted outlet, rating include the effect of duct end correction.

- The AMCA Certified Ratings Seal applies to air performance only. dBA levels are not licensed by AMCA international.

# TDA 630-V / 12AA/ 12-12/ \_ \_ / \_ 1450rpm - 50Hz

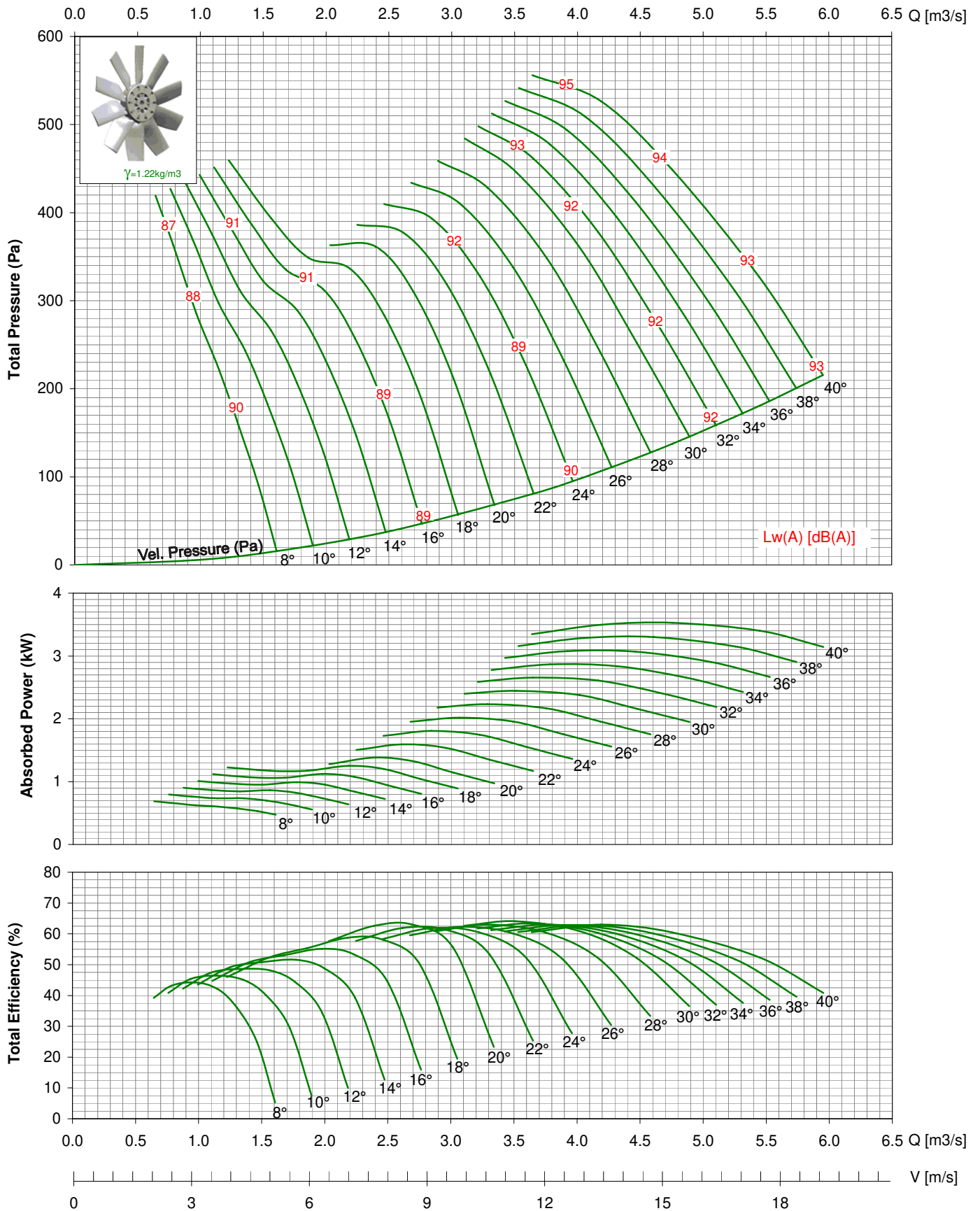

- Performance certified for installation type D - ducted inlet, ducted outlet. Performance ratings do not include the effects of appurtenances (accessories).  
 - Power ratings (kW) does not include transmission losses.  
 - The A-weighted sound ratings shown have been calculated per AMCA Standard 301. Values shown are for inlet  $L_{wi}(A)$  sound power level for installation type D - ducted inlet, ducted outlet, rating include the effect of duct end correction.  
 - The AMCA Certified Ratings Seal applies to air performance only. dBA levels are not licensed by AMCA international.

# TDA 630-V / 12AA/ 12-12/ \_ \_ / \_ 1150rpm - 60Hz

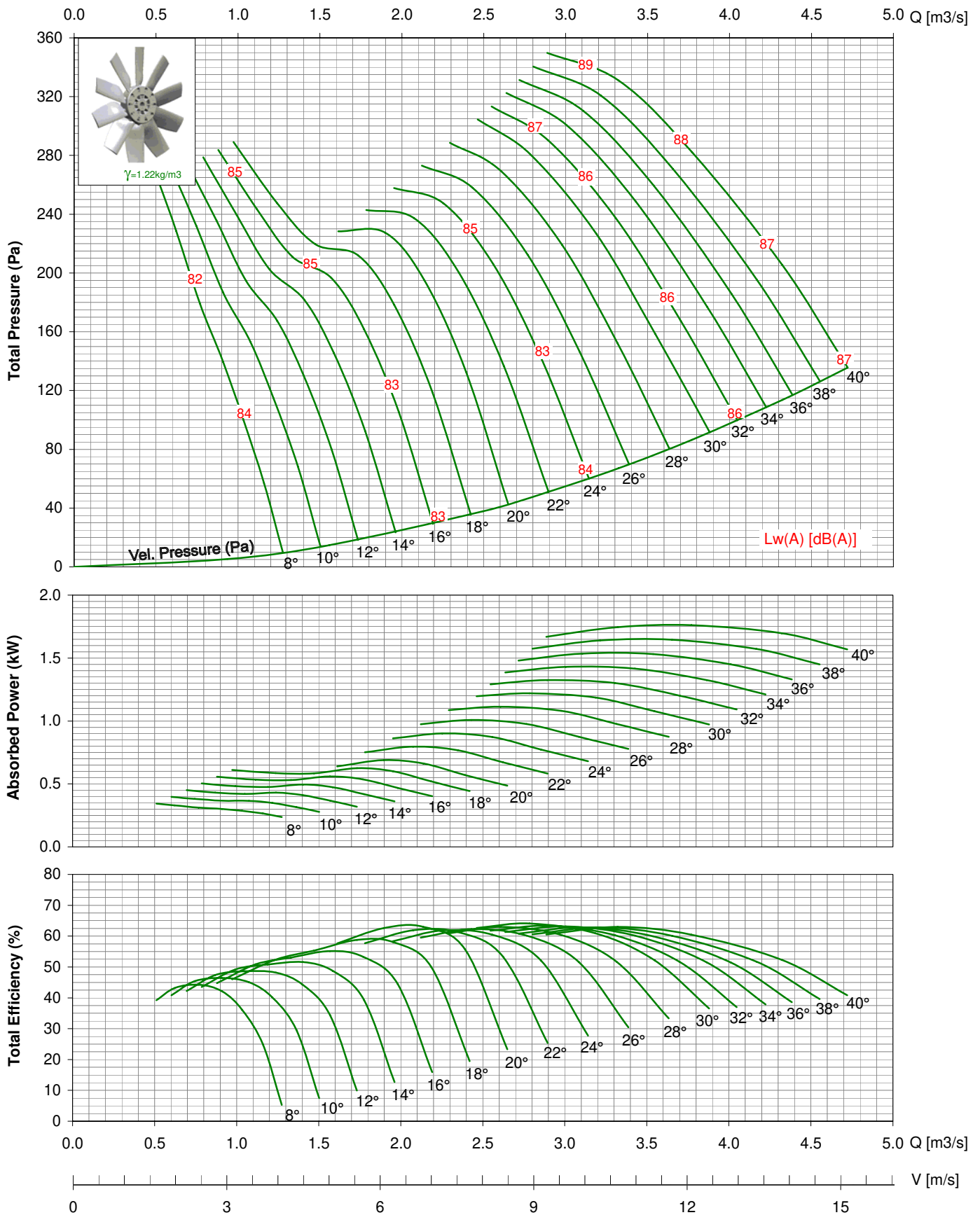

- Performance certified for installation type D - ducted inlet, ducted outlet. Performance ratings do not include the effects of appurtenances (accessories).
- Power ratings (kW) does not include transmission losses.
- The A-weighted sound ratings shown have been calculated per AMCA Standard 301. Values shown are for inlet Lw(A) sound power level for installation type D - ducted inlet, ducted outlet, rating include the effect of duct end correction.
- The AMCA Certified Ratings Seal applies to air performance only. dBA levels are not licensed by AMCA international.

# TDA 630-V / 12AA/ 12-12/ \_\_ / \_ 1750rpm - 60Hz

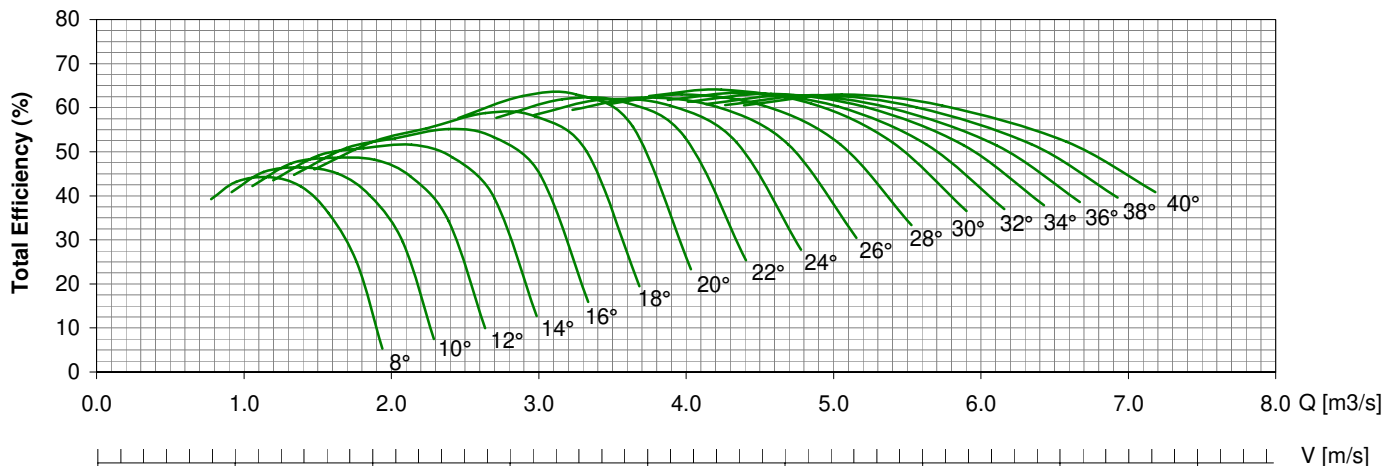
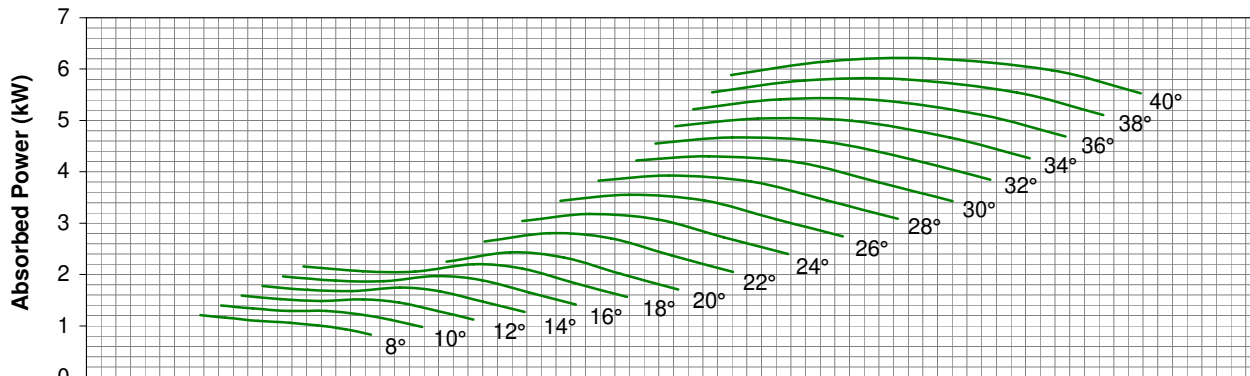
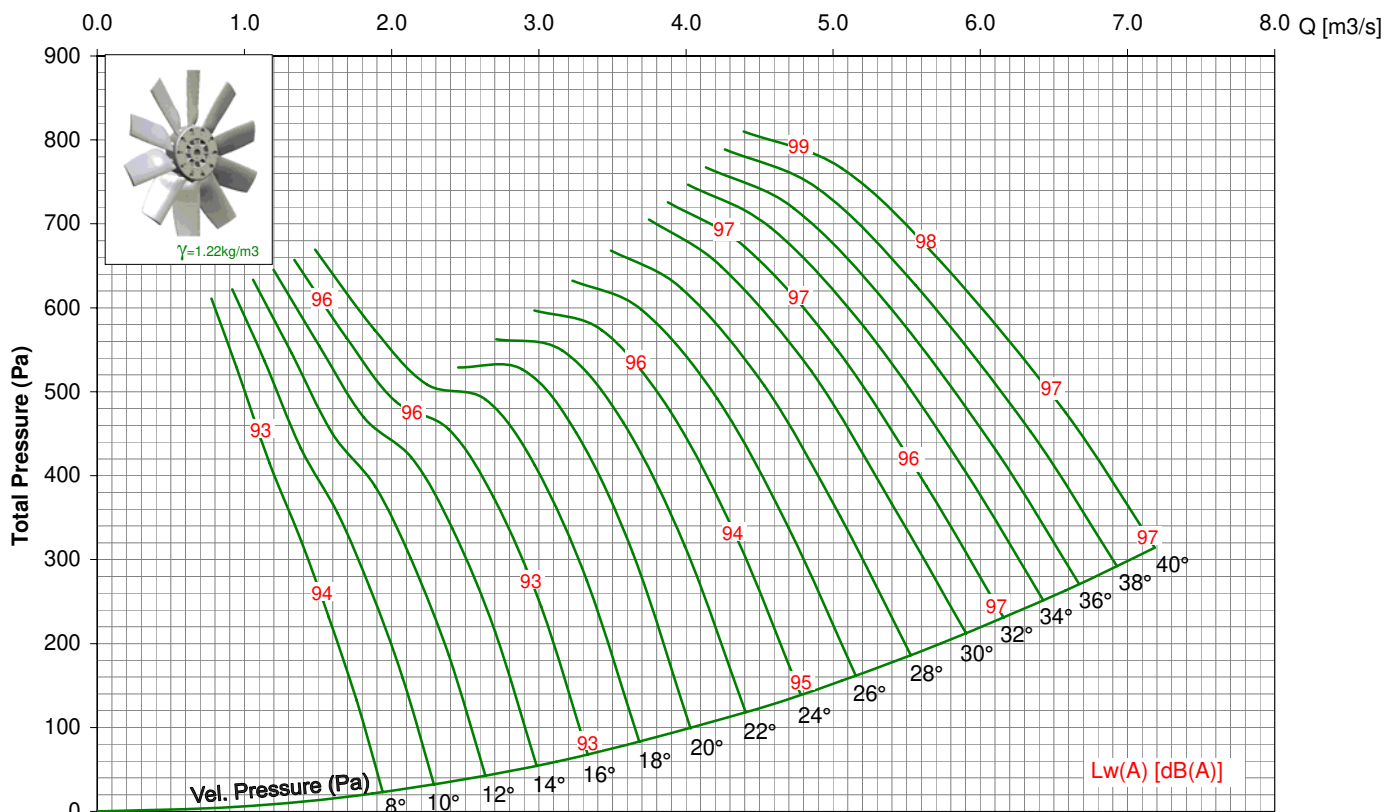

0 3 6 9 12 15 18 21 24 V [m/s]

- Performance certified for installation type D - ducted inlet, ducted outlet. Performance ratings do not include the effects of appurtenances (accessories).
- Power ratings (kW) does not include transmission losses.
- The A-weighted sound ratings shown have been calculated per AMCA Standard 301. Values shown are for inlet Lwi(A) sound power level for installation type D - ducted inlet, ducted outlet, rating include the effect of duct end correction.
- The AMCA Certified Ratings Seal applies to air performance only. dBA levels are not licensed by AMCA international.



# VANE AXIAL FAN DIRECT DRIVEN

## Series TDA-V



### Features

For commercial and industrial applications where large volumes of air are required at moderate to high pressure, special designed integral straightening vanes, reduced turbulence, provide high performance and low sound level.

### Construction

Double flanged casing is produced in mild steel or galvanised Steel, the impeller having manually adjustable pitch aerofoil blades is made of PPG, PAG or pressure-casted Aluminium.

### Finish

Available in standard finishes of galvanisation or painting.

### Operating Temperature

-20°C to +55°C

### Motors

Totally enclosed Class 'F' motor, to a min. IP54 protection are fitted as standard. Standard motor up to 2.2kW are usually supplied on DOL starting, motor 3.0kW and above are star/delta starting.

### Airflow Direction

Air flowing from impeller to motor is fitted as standard.



Kruger\* certifies that the TDA 710 -V shown herein is licensed to bear the AMCA Seal. The ratings shown are based on tests and procedures performed in accordance with AMCA publication 211 and comply with the requirements of the AMCA Certified Ratings Program.

- \*Kruger Ventilation Industries Asia Co., Ltd
- \*Guangzhou Kruger Ventilation Co., Ltd
- \*Kruger Ventilation (Taiwan) Co., Ltd
- \*Kruger Ventilation Industries (Vietnam) Co., Ltd
- \*Kruger Ventilation Industries (India) Pvt. Ltd
- \*Kruger Ventilation Industries (North India) Pvt. Ltd
- \*Kruger Ventilation Industries (Thailand) Co., Ltd
- \*Kruvent Industries (M) Sdn. Bhd
- \*P.T. Kruger Ventilation Indonesia
- \*Shanghai Kruger Ventilation Co., Ltd
- \*Wuhan Kruger Ventilation Co., Ltd

**MODEL: TDA 710-V / 14AA / 12-12 / \_ / \_**

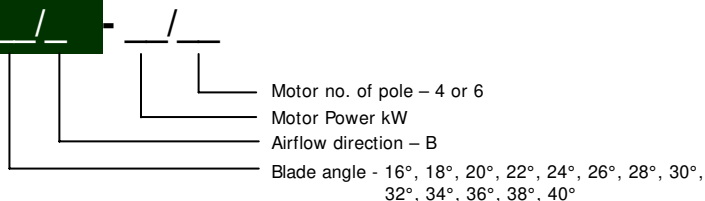

\* All Dimension in mm

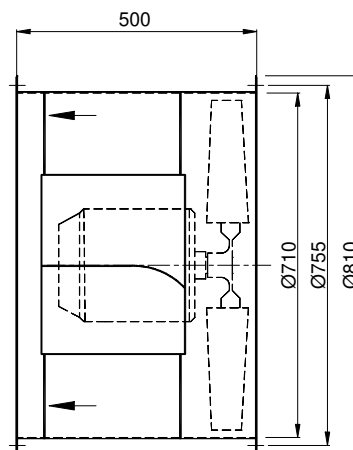
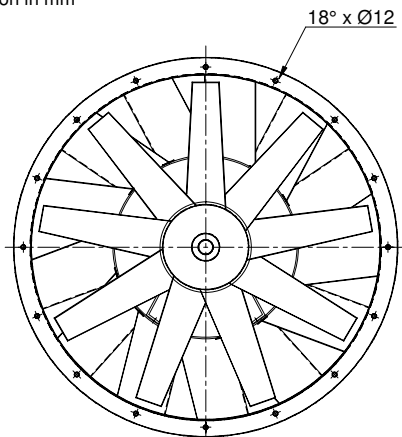

# TDA 710-V / 14AA/ 12-12/ \_\_ / \_

## 950rpm - 50Hz

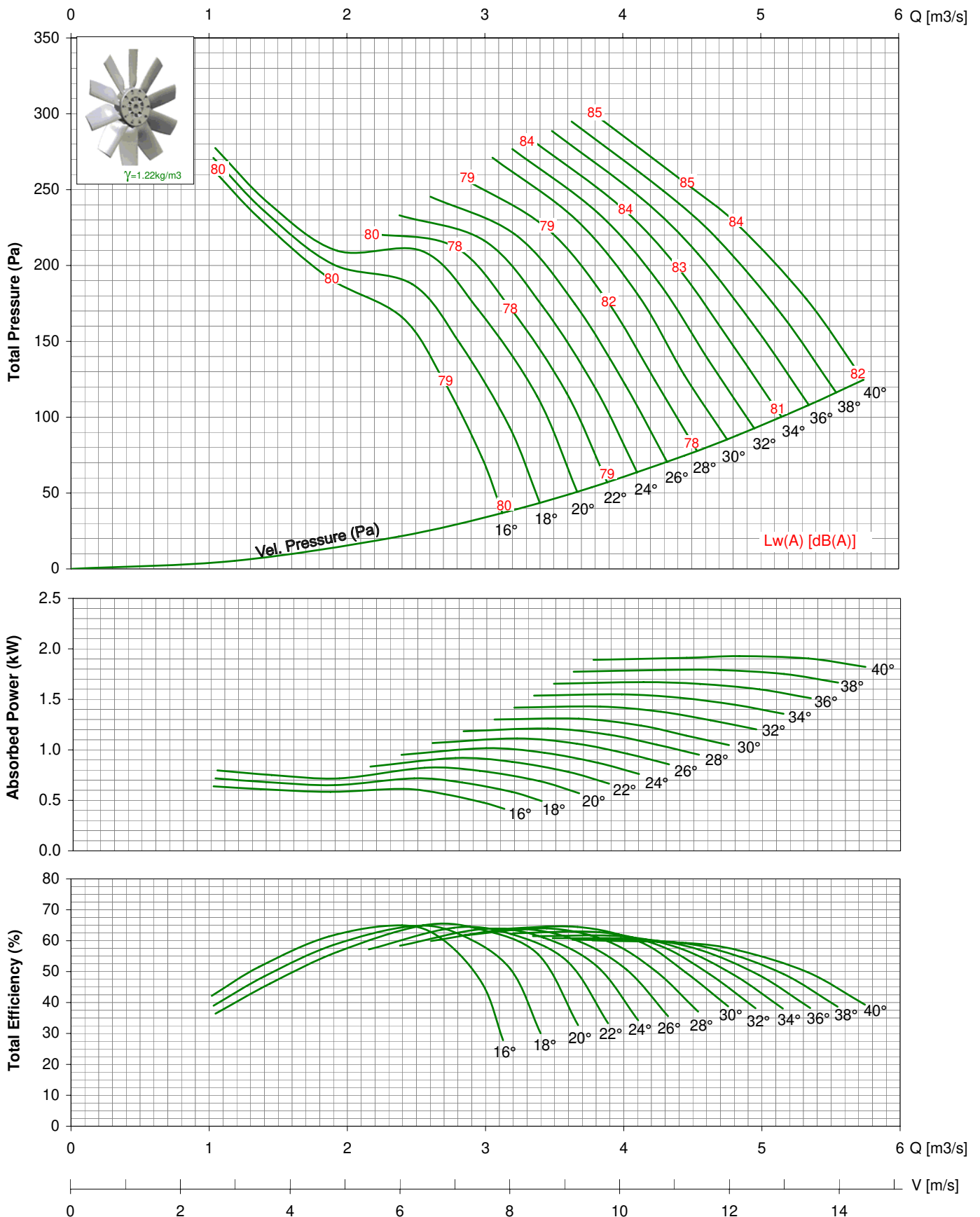

- Performance certified for installation type D - ducted inlet, ducted outlet. Performance ratings do not include the effects of appurtenances (accessories).
- Power ratings (kW) does not include transmission losses.
- The A-weighted sound ratings shown have been calculated per AMCA Standard 301. Values shown are for inlet Lwi(A) sound power level for installation type D - ducted inlet, ducted outlet, rating include the effect of duct end correction.
- The AMCA Certified Ratings Seal applies to air performance only. dBA levels are not licensed by AMCA international.

# TDA 710-V / 14AA/ 12-12/ \_\_ / \_ 1450rpm - 50Hz

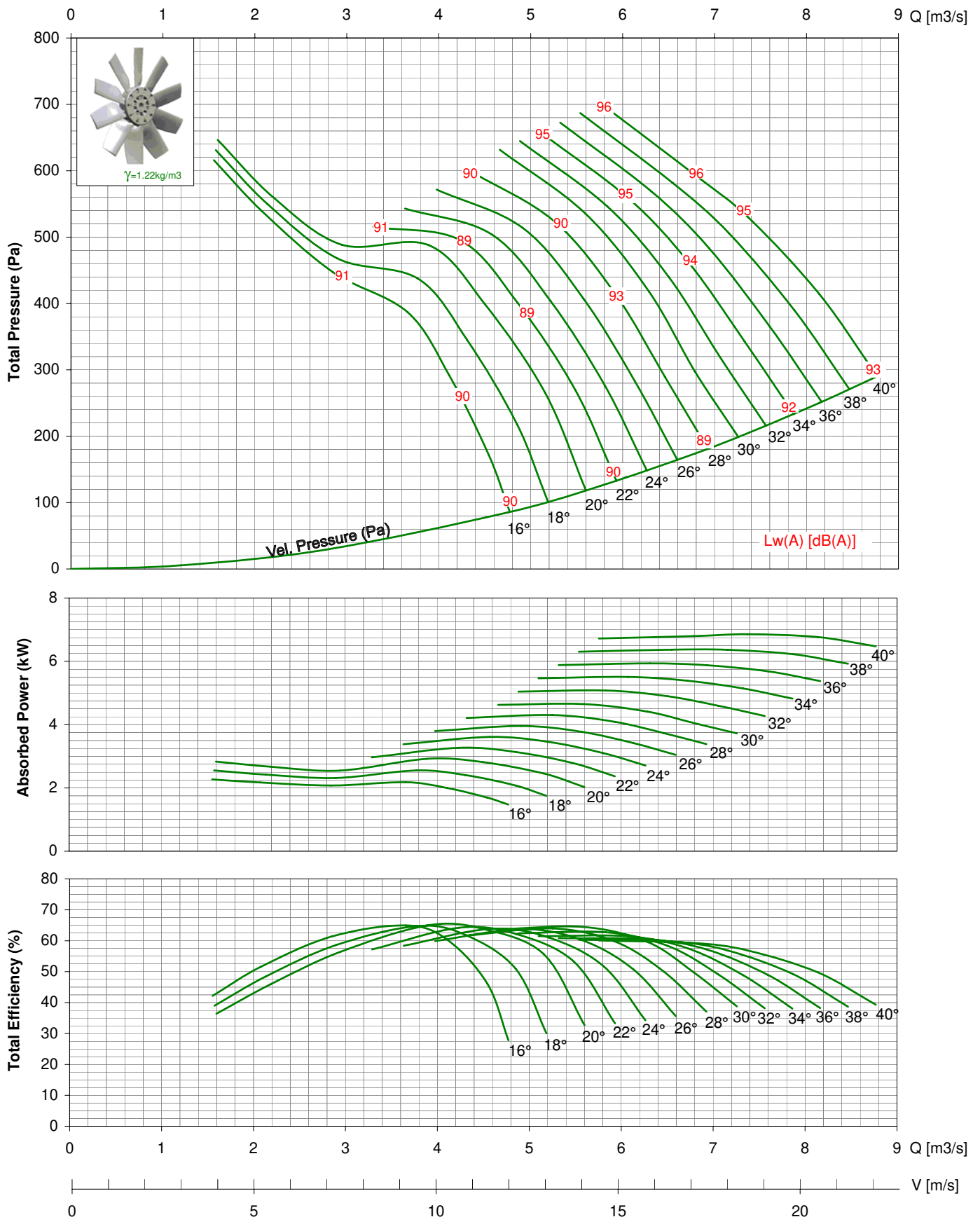

- Performance certified is for installation type D - ducted inlet, ducted outlet. Performance ratings do not include the effects of appurtenances (accessories).
- Power ratings (kW) does not include transmission losses.
- The A-weighted sound ratings shown have been calculated per AMCA Standard 301. Values shown are for Inlet Lwi(A) sound power level for installation type D - ducted inlet, ducted outlet, rating include the effect of duct end correction.
- The AMCA Certified Ratings Seal applies to air performance only. dBA levels are not licensed by AMCA international.

# TDA 710-V / 14AA/ 12-12/ \_ \_ / \_ 1150rpm - 60Hz

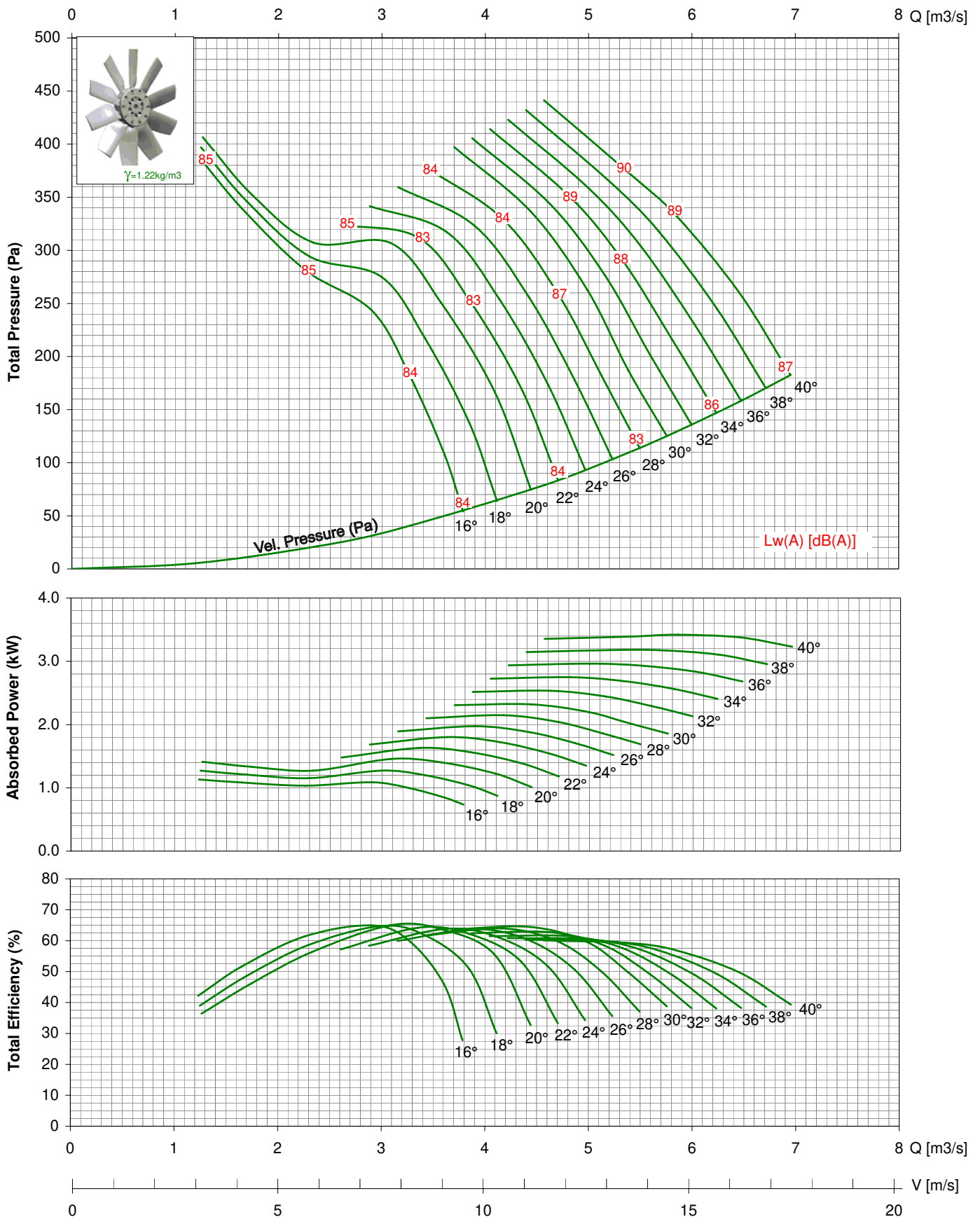

- Performance certified is for installation type D - ducted inlet, ducted outlet. Performance ratings do not include the effects of appurtenances (accessories).
- Power ratings (kW) does not include transmission losses.
- The A-weighted sound ratings shown have been calculated per AMCA Standard 301. Values shown are for inlet Lwi(A) sound power level for installation type D - ducted inlet, ducted outlet, rating include the effect of duct end correction.
- The AMCA Certified Ratings Seal applies to air performance only. dBA levels are not licensed by AMCA international.

# TDA 710-V / 14AA/ 12-12/ \_\_ / \_ 1750rpm - 60Hz

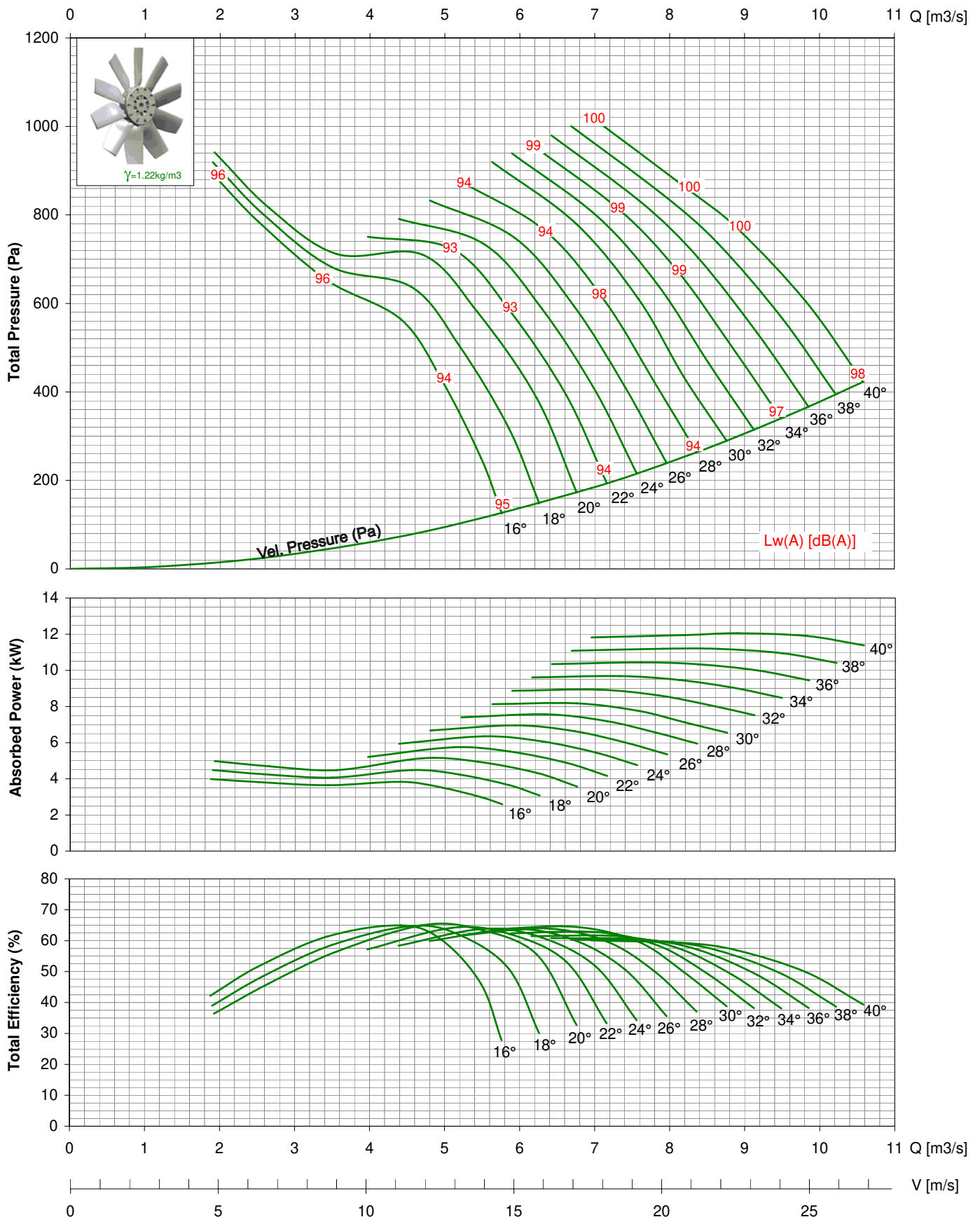

- Performance certified for installation type D - ducted inlet, ducted outlet. Performance ratings do not include the effects of appurtenances (accessories).
- Power ratings (kW) does not include transmission losses.
- The A-weighted sound ratings shown have been calculated per AMCA Standard 301. Values shown are for inlet  $L_{wi}(A)$  sound power level for installation type D - ducted inlet, ducted outlet, rating include the effect of duct end correction.
- The AMCA Certified Ratings Seal applies to air performance only. dBA levels are not licensed by AMCA international.



# VANE AXIAL FAN DIRECT DRIVEN

## Series TDA-V



### Features

For commercial and industrial applications where large volumes of air are required at moderate to high pressure, special designed integral straightening vanes, reduced turbulence, provide high performance and low sound level.

### Construction

Double flanged casing is produced in mild steel or galvanised Steel, the impeller having manually adjustable pitch aerofoil blades is made of PPG, PAG or pressure-casted Aluminium.

### Finish

Available in standard finishes of galvanisation or painting.

### Operating Temperature

-20°C to +55°C

### Motors

Totally enclosed Class 'F' motor, to a min. IP54 protection are fitted as standard. Standard motor up to 2.2kW are usually supplied on DOL starting, motor 3.0kW and above are star/delta starting.

### Airflow Direction

Air flowing from impeller to motor is fitted as standard.



Kruger\* certifies that the TDA 800 -V shown herein is licensed to bear the AMCA Seal. The ratings shown are based on tests and procedures performed in accordance with AMCA publication 211 and comply with the requirements of the AMCA Certified Ratings Program.

- \*Kruger Ventilation Industries Asia Co., Ltd
- \*Guangzhou Kruger Ventilation Co., Ltd
- \*Kruger Ventilation (Taiwan) Co., Ltd
- \*Kruger Ventilation Industries (Vietnam) Co., Ltd
- \*Kruger Ventilation Industries (India) Pvt. Ltd
- \*Kruger Ventilation Industries (North India) Pvt. Ltd
- \*Kruger Ventilation Industries (Thailand) Co., Ltd
- \*Kruvent Industries (M) Sdn. Bhd
- \*P.T. Kruger Ventilation Indonesia
- \*Shanghai Kruger Ventilation Co., Ltd
- \*Wuhan Kruger Ventilation Co., Ltd

## MODEL: TDA 800-V / 14AA / 12-12 / \_ / \_

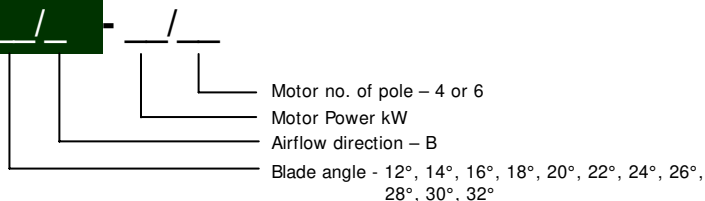

\* All Dimension in mm

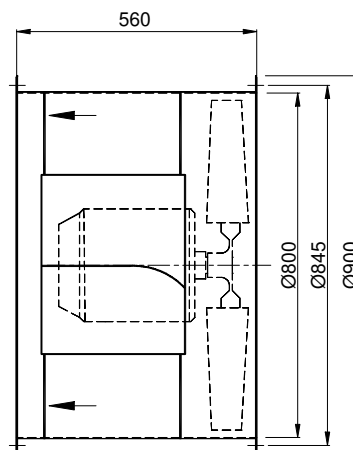
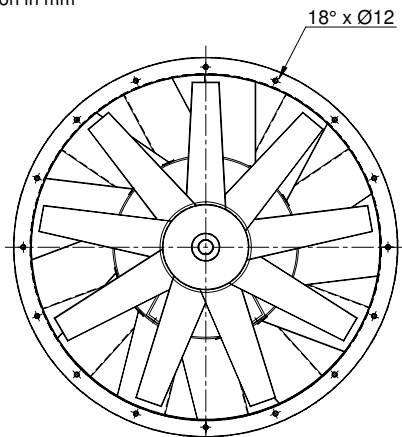

# TDA 800-V / 14AA/ 12-12/ \_ \_ / \_ 950rpm - 50Hz

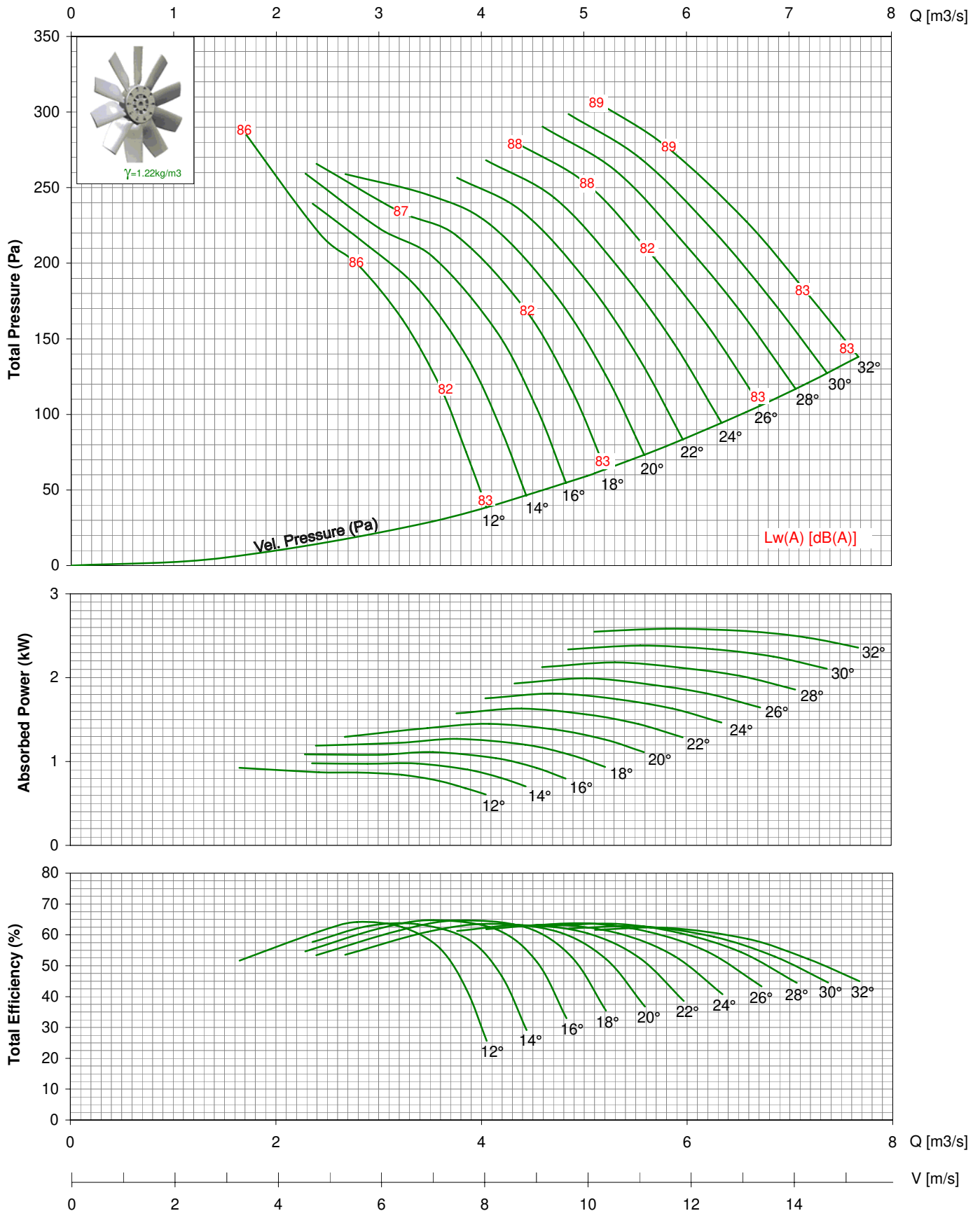

- Performance certified is for installation type D - ducted inlet, ducted outlet. Performance ratings do not include the effects of appurtenances (accessories).

- Power ratings (kW) does not include transmission losses.

- The A-weighted sound ratings shown have been calculated per AMCA Standard 301. Values shown are for inlet  $L_{wi}(A)$  sound power level for installation type D - ducted inlet, ducted outlet, rating include the effect of duct end correction.

- The AMCA Certified Ratings Seal applies to air performance only. dBA levels are not licensed by AMCA international.

# TDA 800-V / 14AA/ 12-12/ \_\_ / \_ 1450rpm - 50Hz

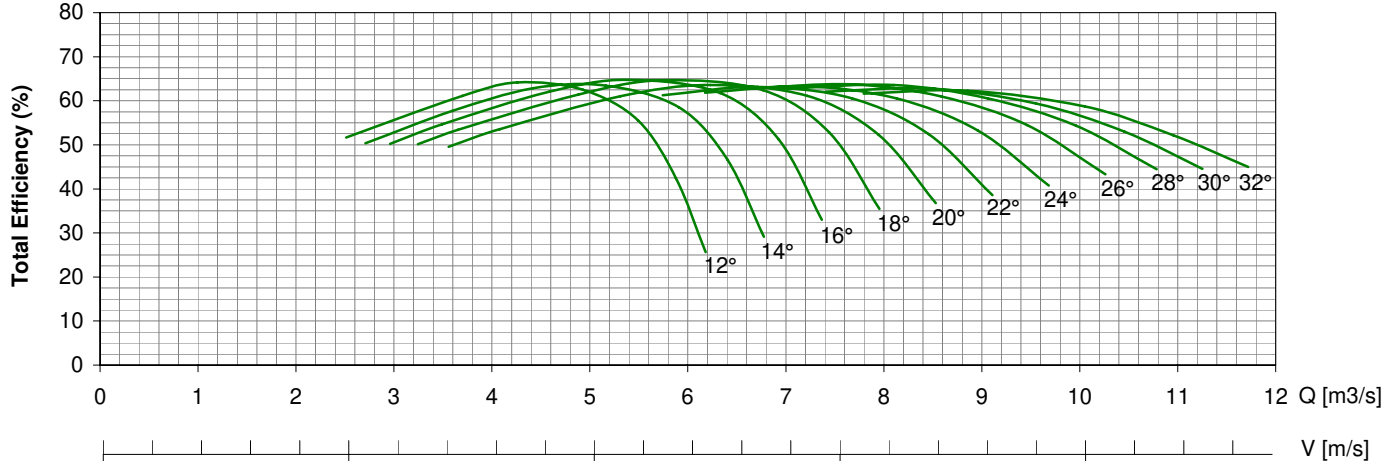
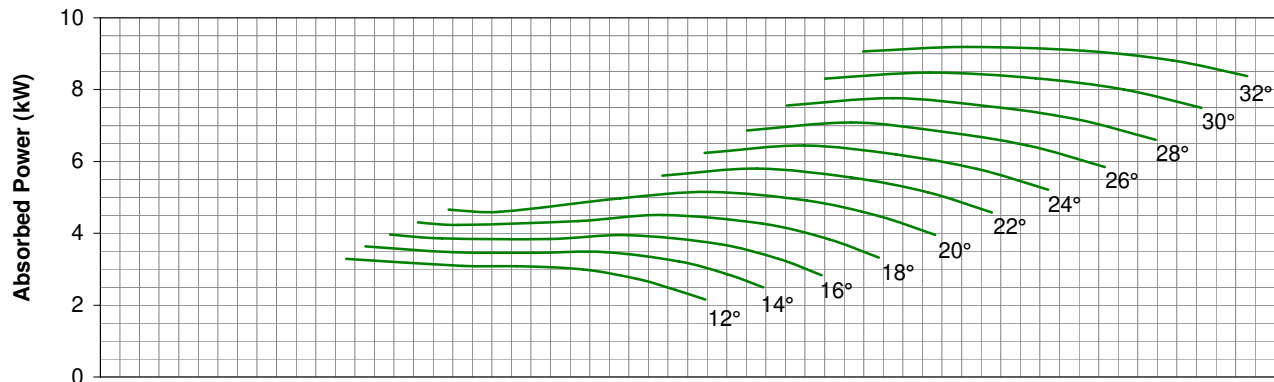
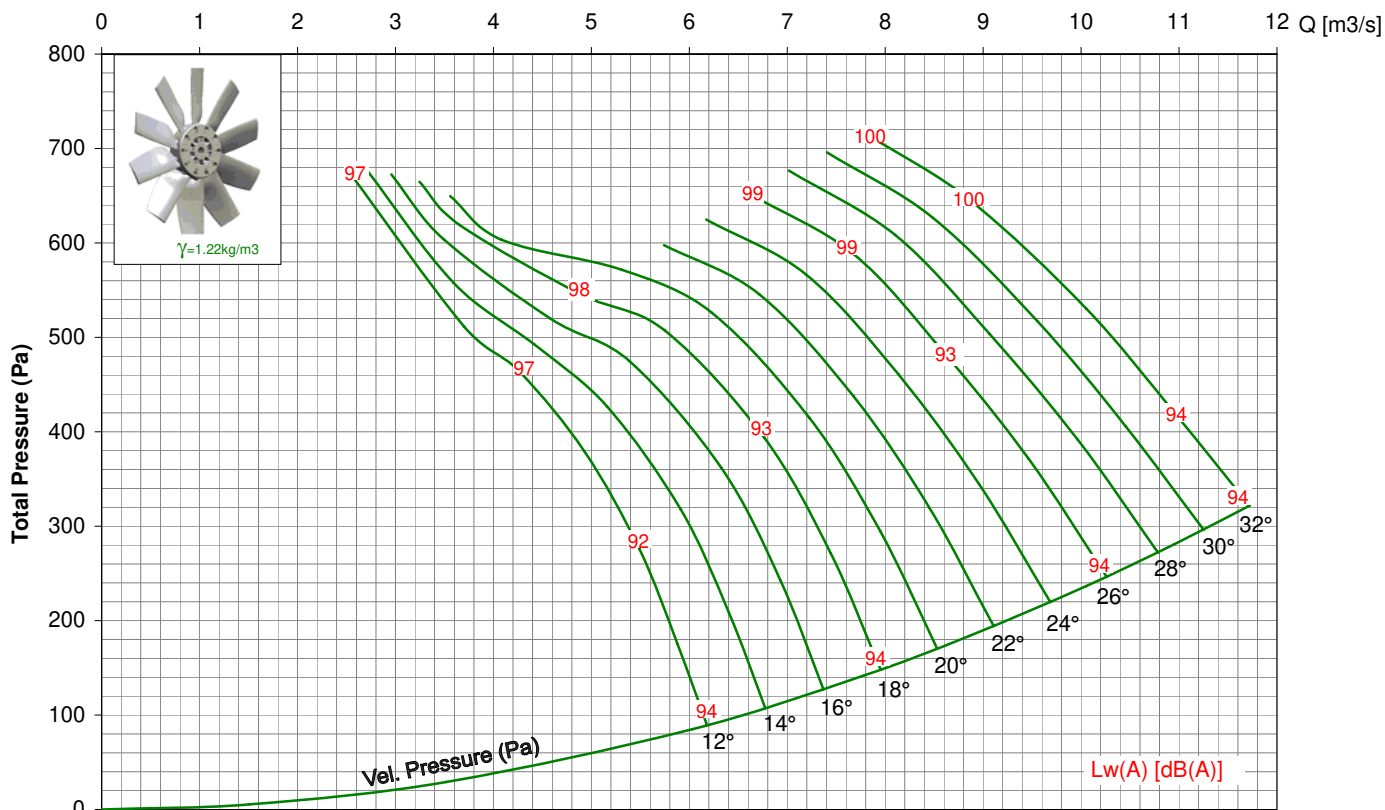

- Performance certified is for installation type D - ducted inlet, ducted outlet. Performance ratings do not include the effects of appurtenances (accessories).
- Power ratings (kW) does not include transmission losses.
- The A-weighted sound ratings shown have been calculated per AMCA Standard 301. Values shown are for inlet Lw(A) sound power level for installation type D - ducted inlet, ducted outlet, rating include the effect of duct end correction.
- The AMCA Certified Ratings Seal applies to air performance only. dBA levels are not licensed by AMCA international.

# TDA 800-V / 14AA/ 12-12/ \_ \_ / \_ 1150rpm - 60Hz

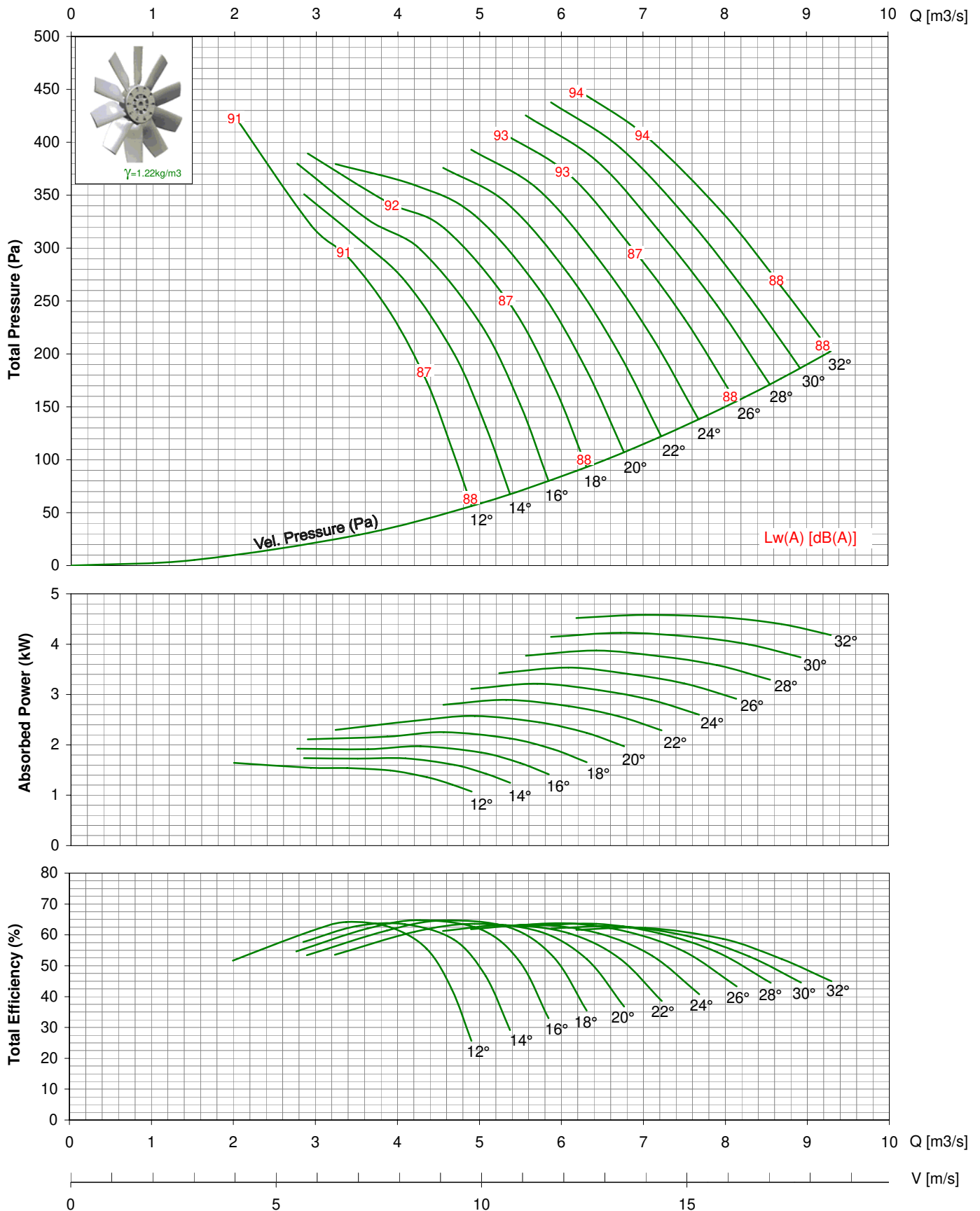

- Performance certified is for installation type D - ducted inlet, ducted outlet. Performance ratings do not include the effects of appurtenances (accessories).

- Power ratings (kW) does not include transmission losses.

- The A-weighted sound ratings shown have been calculated per AMCA Standard 301. Values shown are for inlet Lwi(A) sound power level for installation type D - ducted inlet, ducted outlet, rating include the effect of duct end correction.

- The AMCA Certified Ratings Seal applies to air performance only. dBA levels are not licensed by AMCA international.

# TDA 800-V / 14AA/ 12-12/ \_\_ / \_ 1750rpm - 60Hz

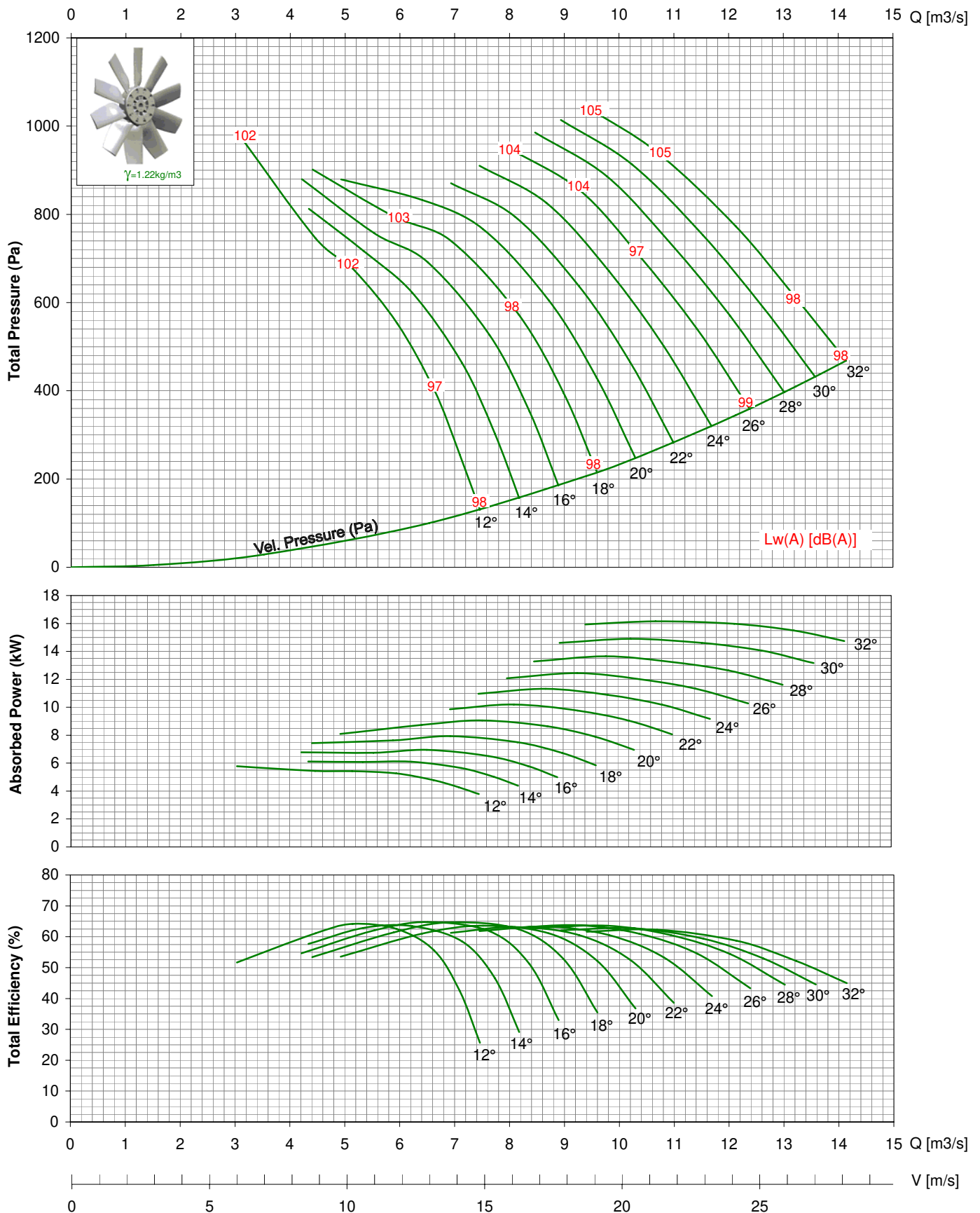

- Performance certified is for installation type D - ducted inlet, ducted outlet. Performance ratings do not include the effects of appurtenances (accessories).
- Power ratings (kW) does not include transmission losses.
- The A-weighted sound ratings shown have been calculated per AMCA Standard 301. Values shown are for inlet Lwi(A) sound power level for installation type D - ducted inlet, ducted outlet, rating include the effect of duct end correction.
- The AMCA Certified Ratings Seal applies to air performance only. dBA levels are not licensed by AMCA international.

# VANE AXIAL FAN DIRECT DRIVEN

## Series TDA-V



### Features

For commercial and industrial applications where large volumes of air are required at moderate to high pressure, special designed integral straightening vanes, reduced turbulence, provide high performance and low sound level.

### Construction

Double flanged casing is produced in mild steel or galvanised Steel, the impeller having manually adjustable pitch aerofoil blades is made of PPG, PAG or pressure-casted Aluminium.

### Finish

Available in standard finishes of galvanisation or painting.

### Operating Temperature

-20°C to +55°C

### Motors

Totally enclosed Class 'F' motor, to a min. IP54 protection are fitted as standard. Standard motor up to 2.2kW are usually supplied on DOL starting, motor 3.0kW and above are star/delta starting.

### Airflow Direction

Air flowing from impeller to motor is fitted as standard.



Kruger\* certifies that the TDA 900 -V shown herein is licensed to bear the AMCA Seal. The ratings shown are based on tests and procedures performed in accordance with AMCA publication 211 and comply with the requirements of the AMCA Certified Ratings Program.

- \*Kruger Ventilation Industries Asia Co., Ltd
- \*Guangzhou Kruger Ventilation Co., Ltd
- \*Kruger Ventilation (Taiwan) Co., Ltd
- \*Kruger Ventilation Industries (Vietnam) Co., Ltd
- \*Kruger Ventilation Industries (India) Pvt. Ltd
- \*Kruger Ventilation Industries (North India) Pvt. Ltd
- \*Kruger Ventilation Industries (Thailand) Co., Ltd
- \*Kruvent Industries (M) Sdn. Bhd
- \*P.T. Kruger Ventilation Indonesia
- \*Shanghai Kruger Ventilation Co., Ltd
- \*Wuhan Kruger Ventilation Co., Ltd

**MODEL: TDA 900-V / 14AA / 12-12 / \_ / \_**

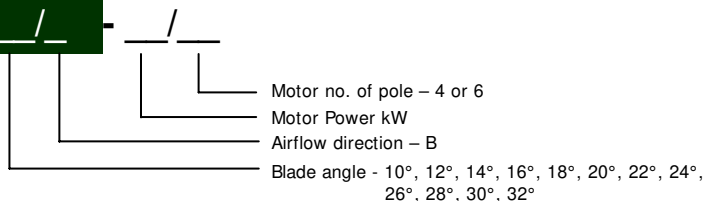

\* All Dimension in mm

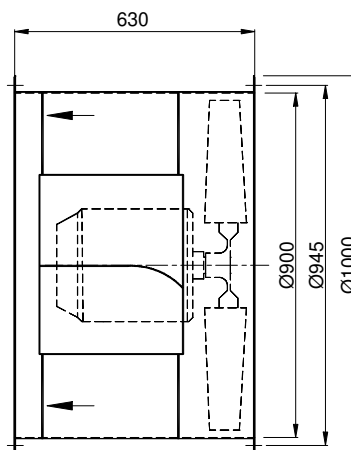
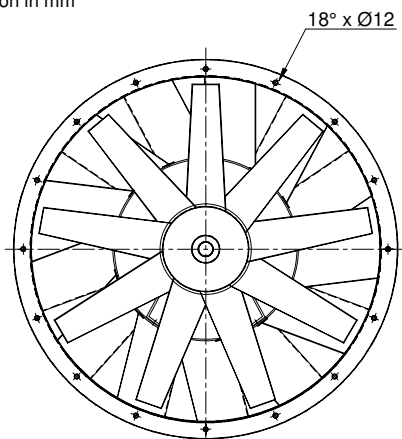

# TDA 900-V / 14AA/ 12-12/ \_\_ / \_

## 950rpm - 50Hz

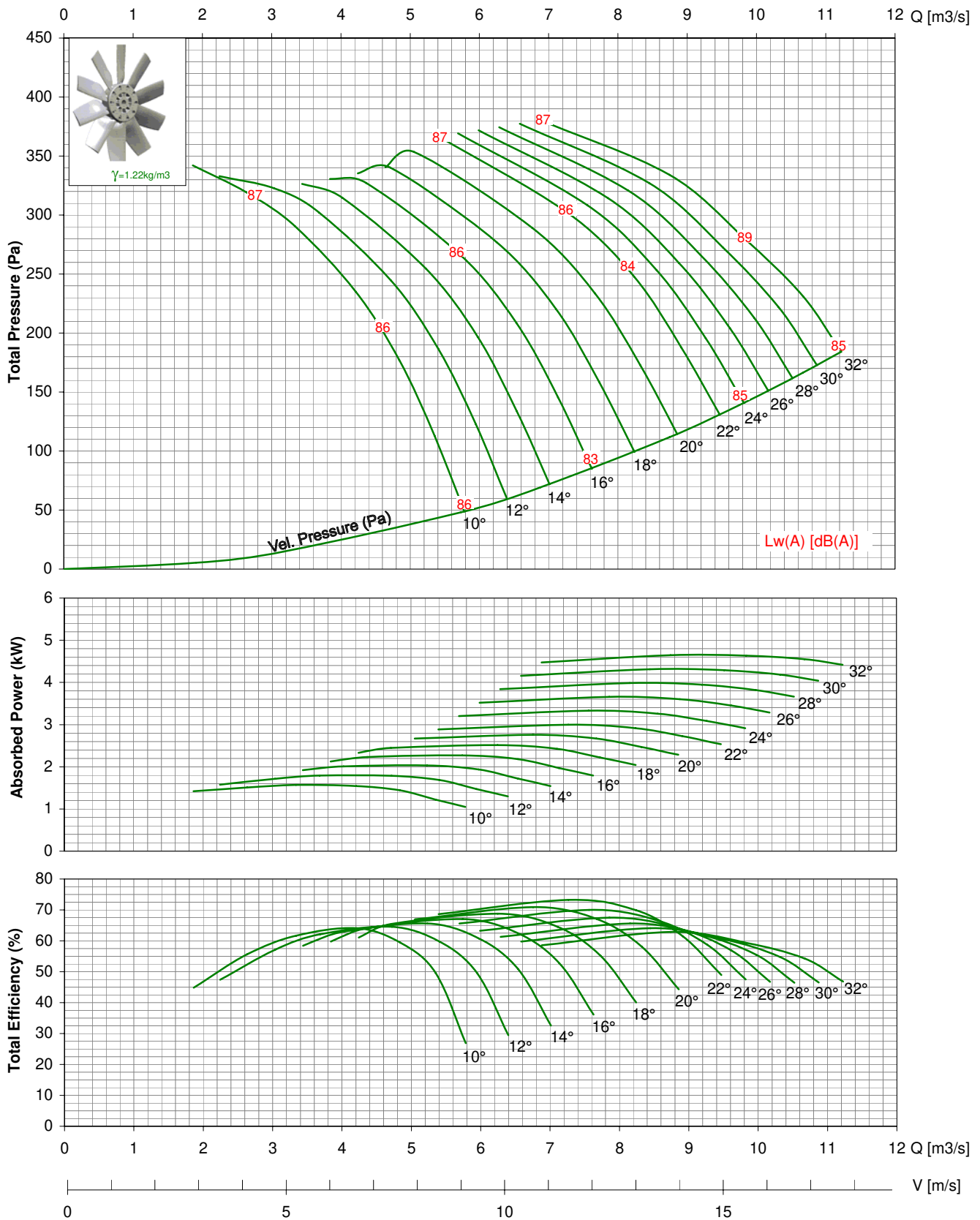

- Performance certified is for installation type D - ducted inlet, ducted outlet. Performance ratings do not include the effects of appurtenances (accessories).
- Power ratings (kW) does not include transmission losses.
- The A-weighted sound ratings shown have been calculated per AMCA Standard 301. Values shown are for inlet  $L_{wi}(A)$  sound power level for installation type D - ducted inlet, ducted outlet, rating include the effect of duct end correction.
- The AMCA Certified Ratings Seal applies to air performance only. dBA levels are not licensed by AMCA international.

# TDA 900-V / 14AA/ 12-12/ \_\_ / \_

## 1450rpm - 50Hz

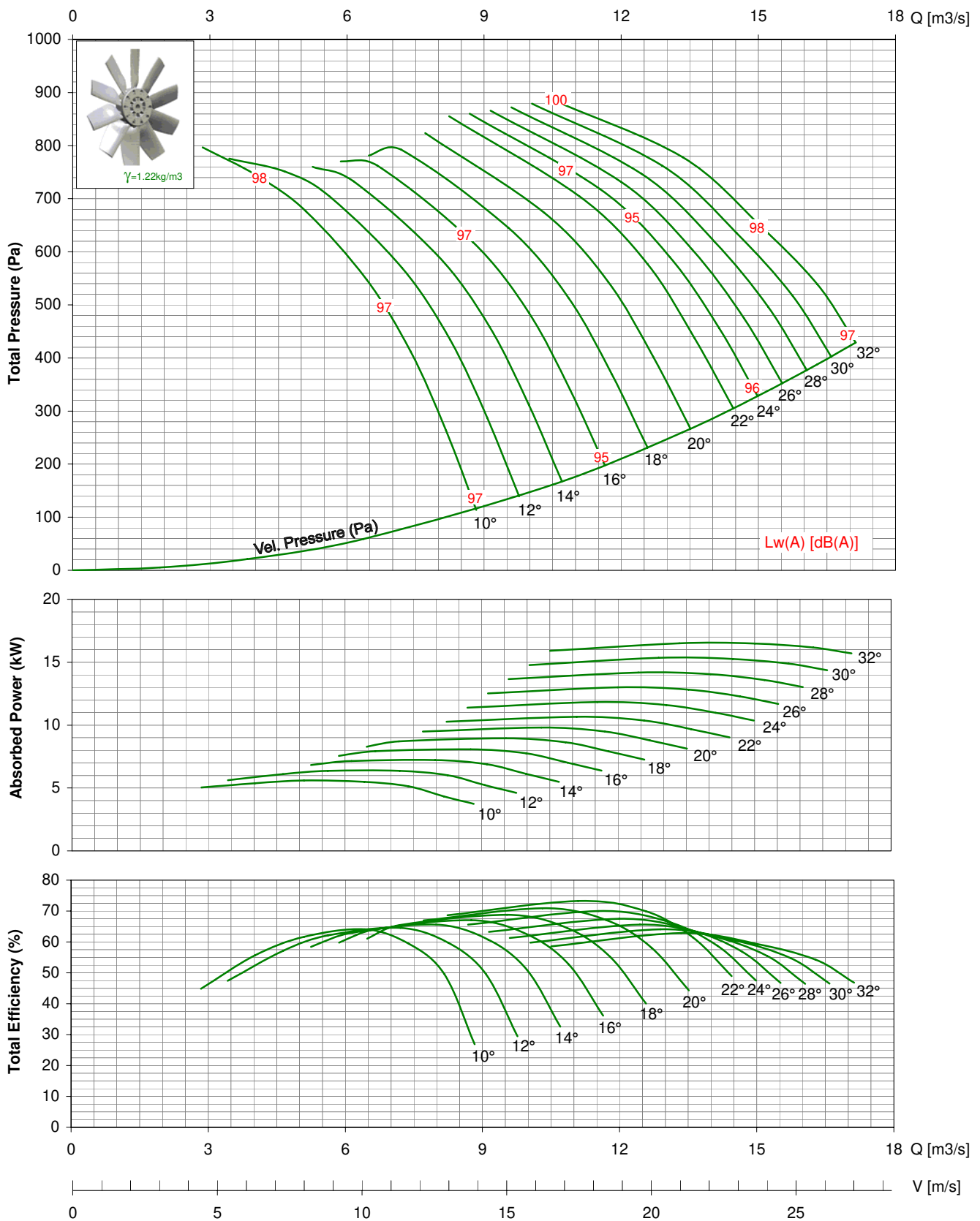

- Performance certified is for installation type D - ducted inlet, ducted outlet. Performance ratings do not include the effects of appurtenances (accessories).
- Power ratings (kW) does not include transmission losses.
- The A-weighted sound ratings shown have been calculated per AMCA Standard 301. Values shown are for inlet Lw(A) sound power level for installation type D - ducted inlet, ducted outlet, rating include the effect of duct end correction.
- The AMCA Certified Ratings Seal applies to air performance only. dBA levels are not licensed by AMCA international.

# TDA 900-V / 14AA/ 12-12/ \_ \_ / \_ 1150rpm - 60Hz

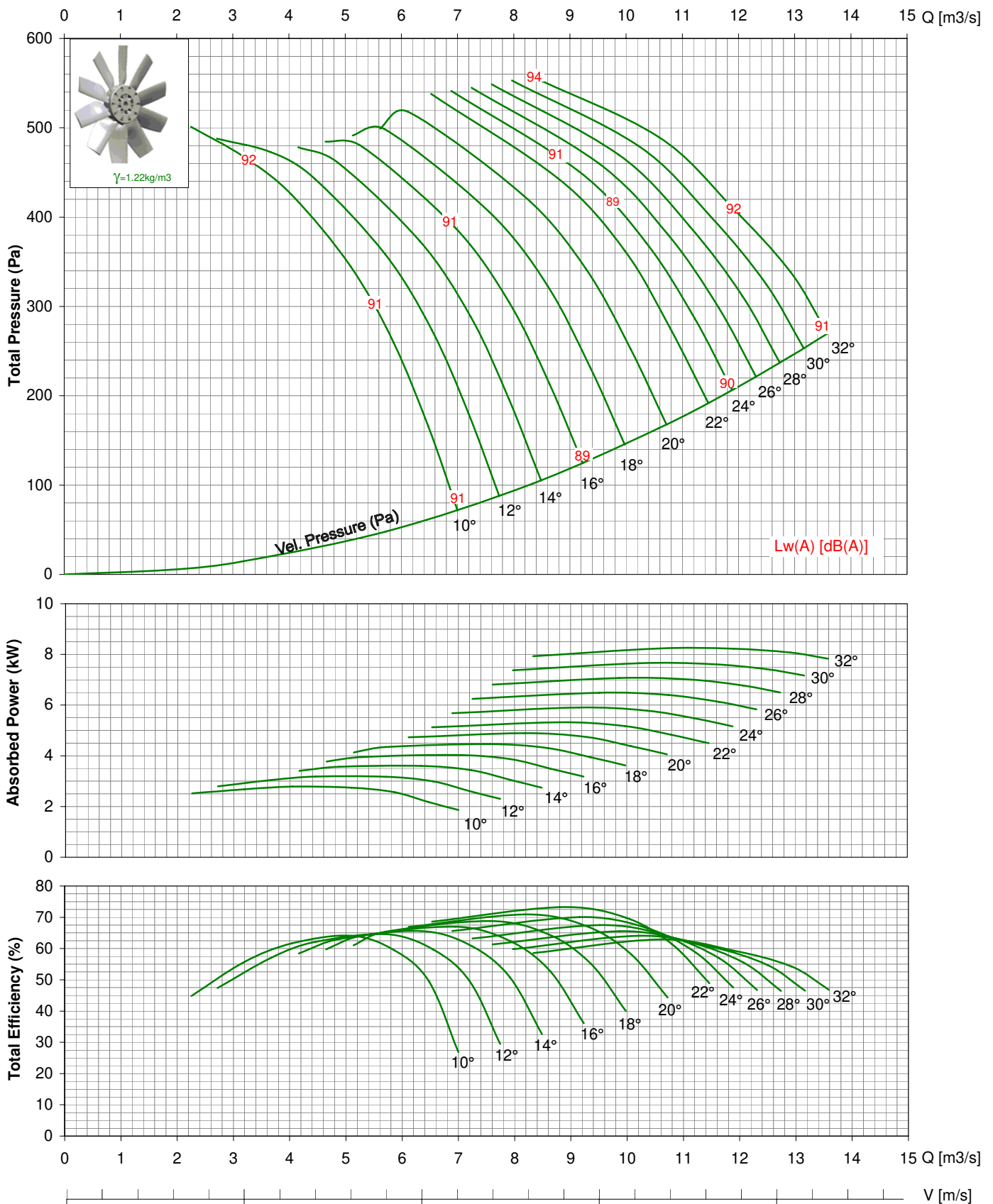

- Performance certified is for installation type D - ducted inlet, ducted outlet. Performance ratings do not include the effects of appurtenances (accessories).
- Power ratings (kW) does not include transmission losses.
- The A-weighted sound ratings shown have been calculated per AMCA Standard 301. Values shown are for inlet  $L_{wi}(A)$  sound power level for installation type D - ducted inlet, ducted outlet, rating include the effect of duct end correction.
- The AMCA Certified Ratings Seal applies to air performance only. dBA levels are not licensed by AMCA international.

# TDA 900-V / 14AA/ 12-12/ \_\_ / \_ 1750rpm - 60Hz

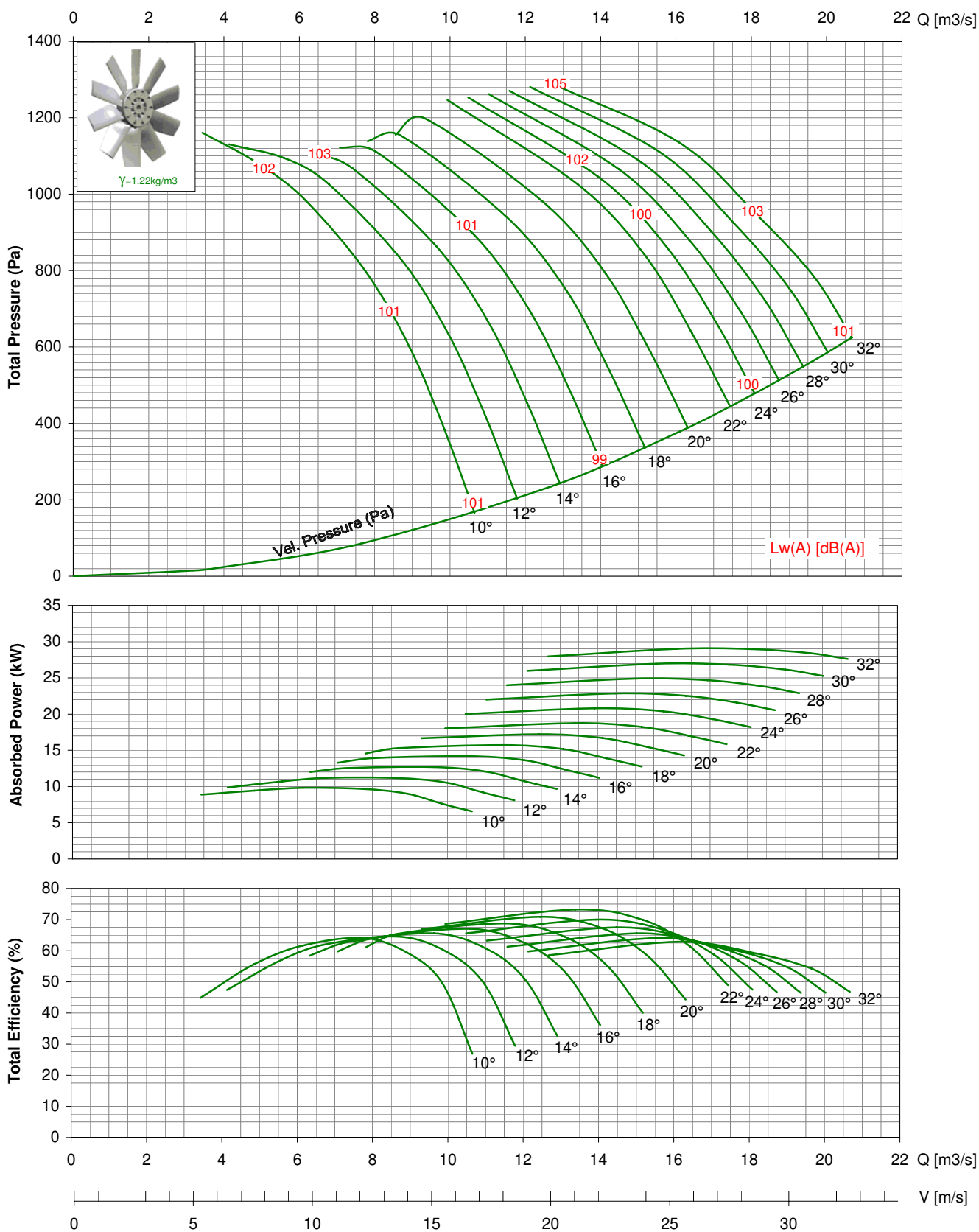

- Performance certified for installation type D - ducted inlet, ducted outlet. Performance ratings do not include the effects of appurtenances (accessories).
- Power ratings (kW) does not include transmission losses.
- The A-weighted sound ratings shown have been calculated per AMCA Standard 301. Values shown are for inlet  $L_{wi}(A)$  sound power level for installation type D - ducted inlet, ducted outlet, rating include the effect of duct end correction.
- The AMCA Certified Ratings Seal applies to air performance only. dBA levels are not licensed by AMCA international.

# VANE AXIAL FAN DIRECT DRIVEN

## Series TDA-V



### Features

For commercial and industrial applications where large volumes of air are required at moderate to high pressure, special designed integral straightening vanes, reduced turbulence, provide high performance and low sound level.

### Construction

Double flanged casing is produced in mild steel or galvanised Steel, the impeller having manually adjustable pitch aerofoil blades is made of PPG, PAG or pressure-casted Aluminium.

### Finish

Available in standard finishes of galvanisation or painting.

### Operating Temperature

-20°C to +55°C

### Motors

Totally enclosed Class 'F' motor, to a min. IP54 protection are fitted as standard. Standard motor up to 2.2kW are usually supplied on DOL starting, motor 3.0kW and above are star/delta starting.

### Airflow Direction

Air flowing from impeller to motor is fitted as standard.



Kruger\* certifies that the TDA 1000 -V shown herein is licensed to bear the AMCA Seal. The ratings shown are based on tests and procedures performed in accordance with AMCA publication 211 and comply with the requirements of the AMCA Certified Ratings Program.

- \*Kruger Ventilation Industries Asia Co., Ltd
- \*Guangzhou Kruger Ventilation Co., Ltd
- \*Kruger Ventilation (Taiwan) Co., Ltd
- \*Kruger Ventilation Industries (Vietnam) Co., Ltd
- \*Kruger Ventilation Industries (India) Pvt. Ltd
- \*Kruger Ventilation Industries (North India) Pvt. Ltd
- \*Kruger Ventilation Industries (Thailand) Co., Ltd
- \*Kruvent Industries (M) Sdn. Bhd
- \*P.T. Kruger Ventilation Indonesia
- \*Shanghai Kruger Ventilation Co., Ltd
- \*Wuhan Kruger Ventilation Co., Ltd

**MODEL: TDA 1000-V / 14AA / 12-12 / \_ / \_ - \_ / \_**

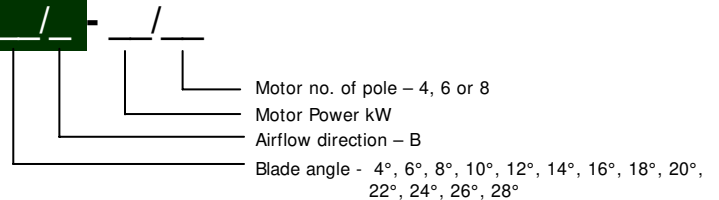

\* All Dimension in mm

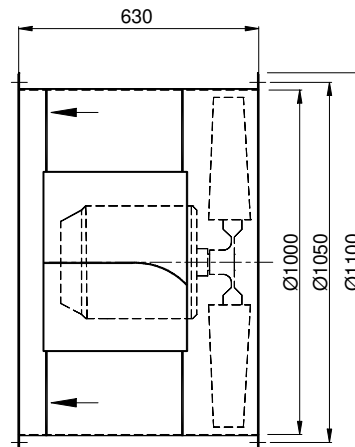
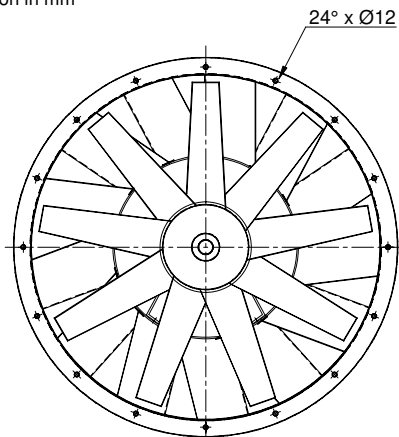

# TDA 1000-V / 14AA/ 12-12/ \_\_ / \_ 725rpm - 50Hz

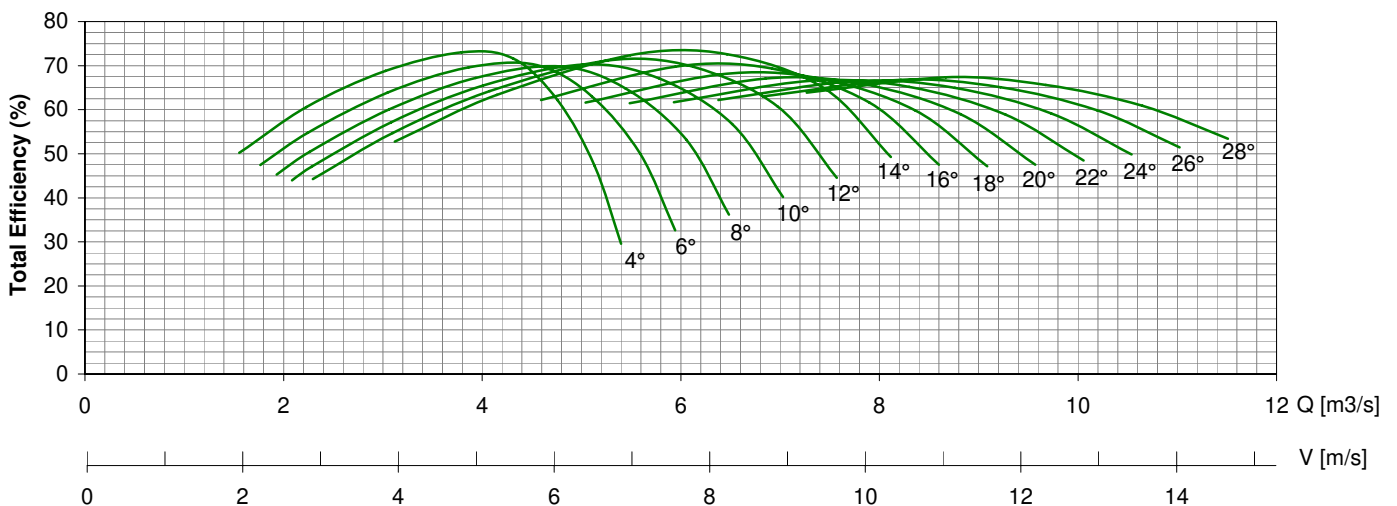
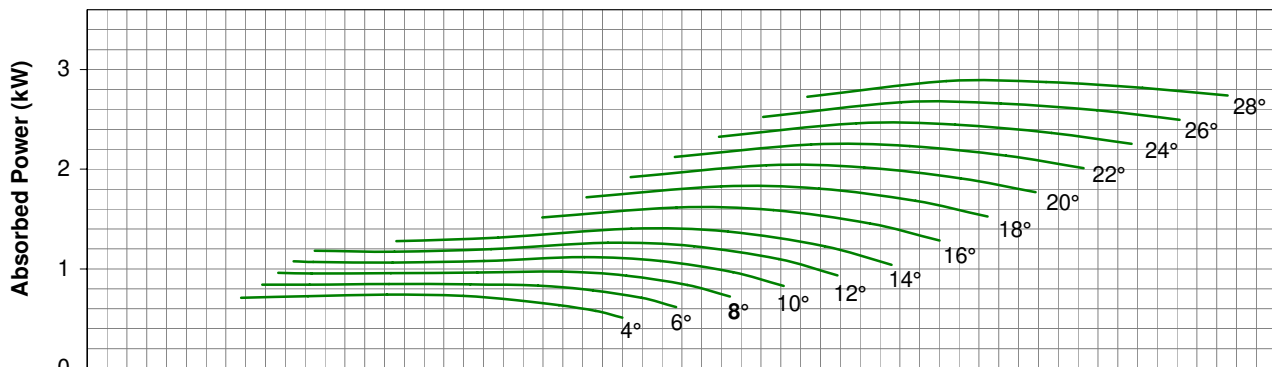
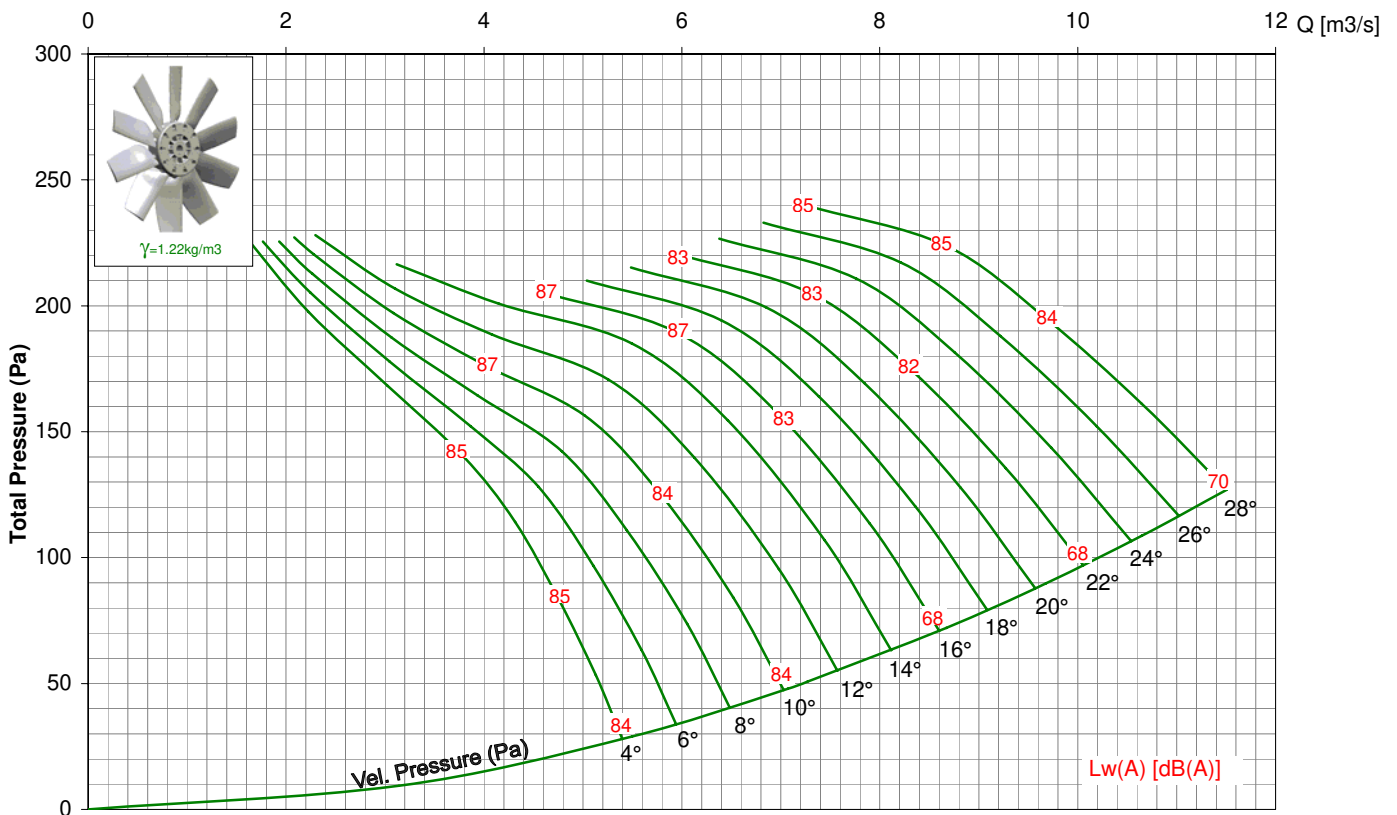

- Performance certified for installation type D - ducted inlet, ducted outlet. Performance ratings do not include the effects of appurtenances (accessories).
- Power ratings (kW) does not include transmission losses.
- The A-weighted sound ratings shown have been calculated per AMCA Standard 301. Values shown are for inlet Lwi(A) sound power level for installation type D - ducted inlet, ducted outlet, rating include the effect of duct end correction
- The AMCA Certified Ratings Seal applies to air performance only. dBA levels are not licensed by AMCA international.

# TDA 1000-V / 14AA/ 12-12/ \_\_ / \_ 950rpm - 50Hz

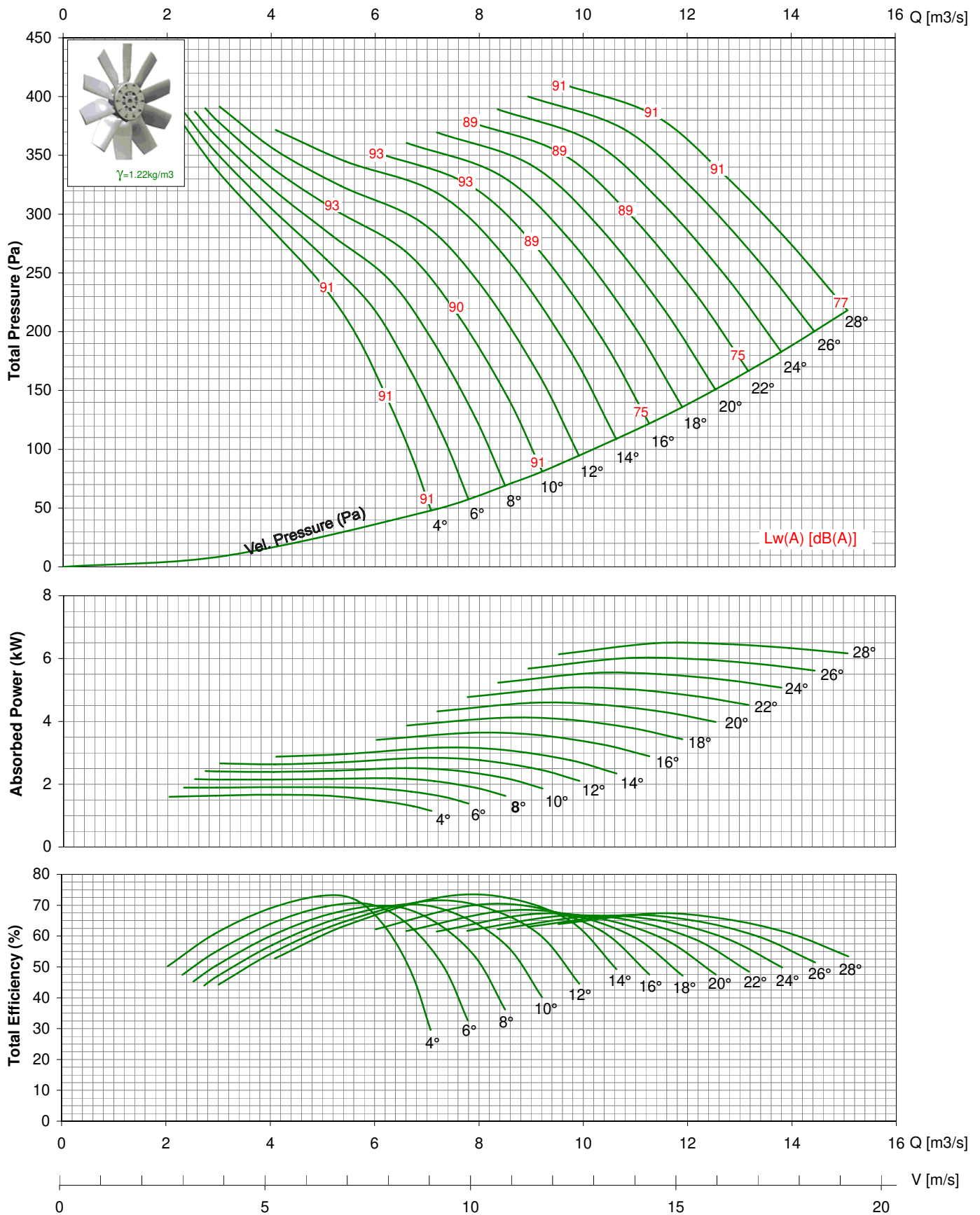

- Performance certified is for installation type D - ducted inlet, ducted outlet. Performance ratings do not include the effects of appurtenances (accessories).
- Power ratings (kW) does not include transmission losses.
- The A-weighted sound ratings shown have been calculated per AMCA Standard 301. Values shown are for inlet Lwi(A) sound power level for installation type D - ducted inlet, ducted outlet, rating include the effect of duct end correction
- The AMCA Certified Ratings Seal applies to air performance only. dBA levels are not licensed by AMCA international.

# TDA 1000-V / 14AA/ 12-12/ \_\_ / \_ 1450rpm - 50Hz

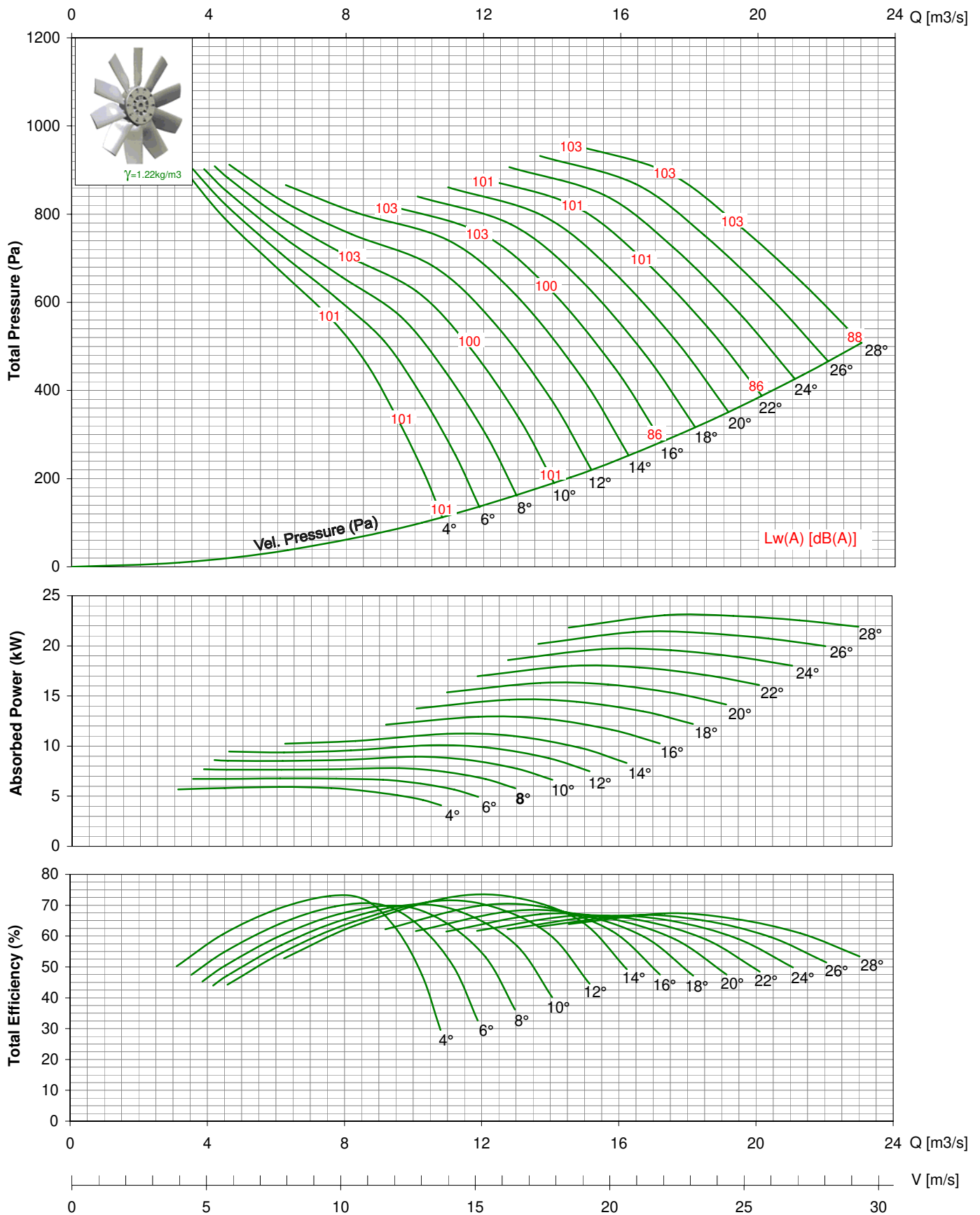

- Performance certified is for installation type D - ducted inlet, ducted outlet. Performance ratings do not include the effects of appurtenances (accessories).
- Power ratings (kW) does not include transmission losses.
- The A-weighted sound ratings shown have been calculated per AMCA Standard 301. Values shown are for inlet Lwi(A) sound power level for installation type D - ducted inlet, ducted outlet, rating include the effect of duct end correction.
- The AMCA Certified Ratings Seal applies to air performance only. dBA levels are not licensed by AMCA international.

# TDA 1000-V / 14AA/ 12-12/ \_\_ / \_ 875rpm - 60Hz

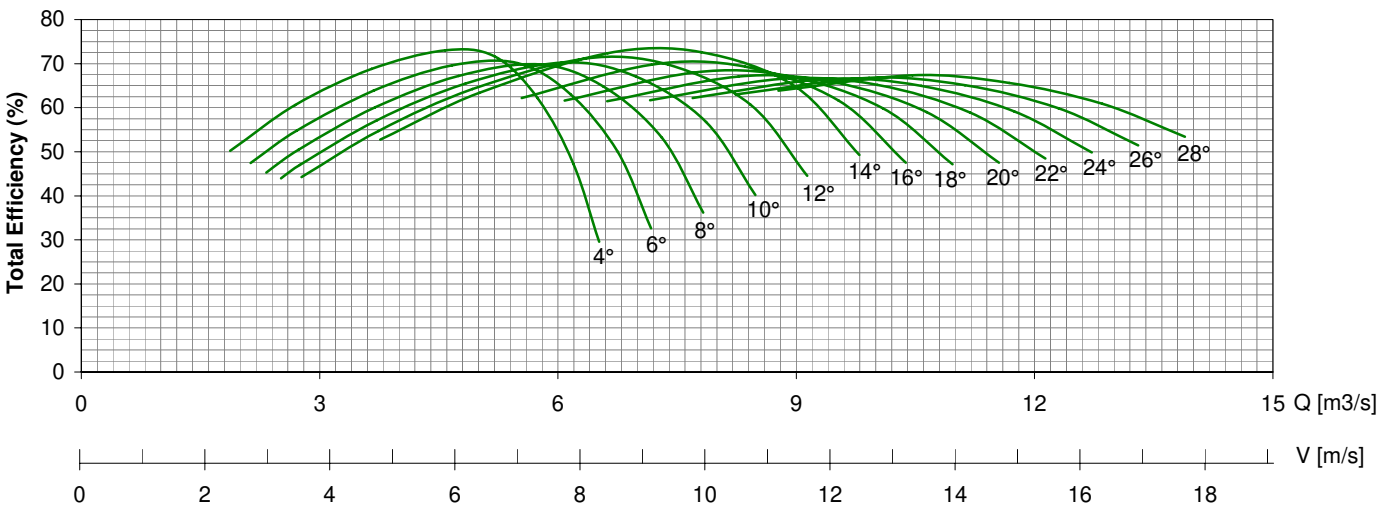
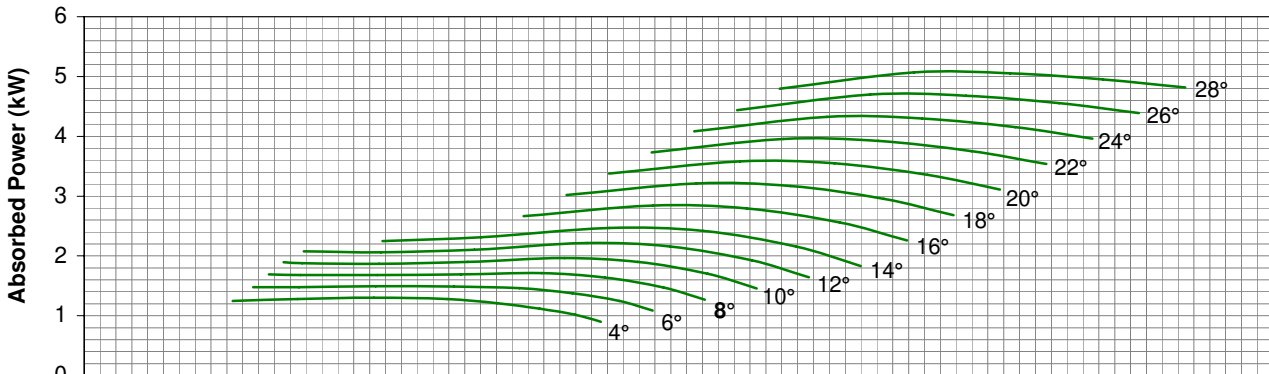
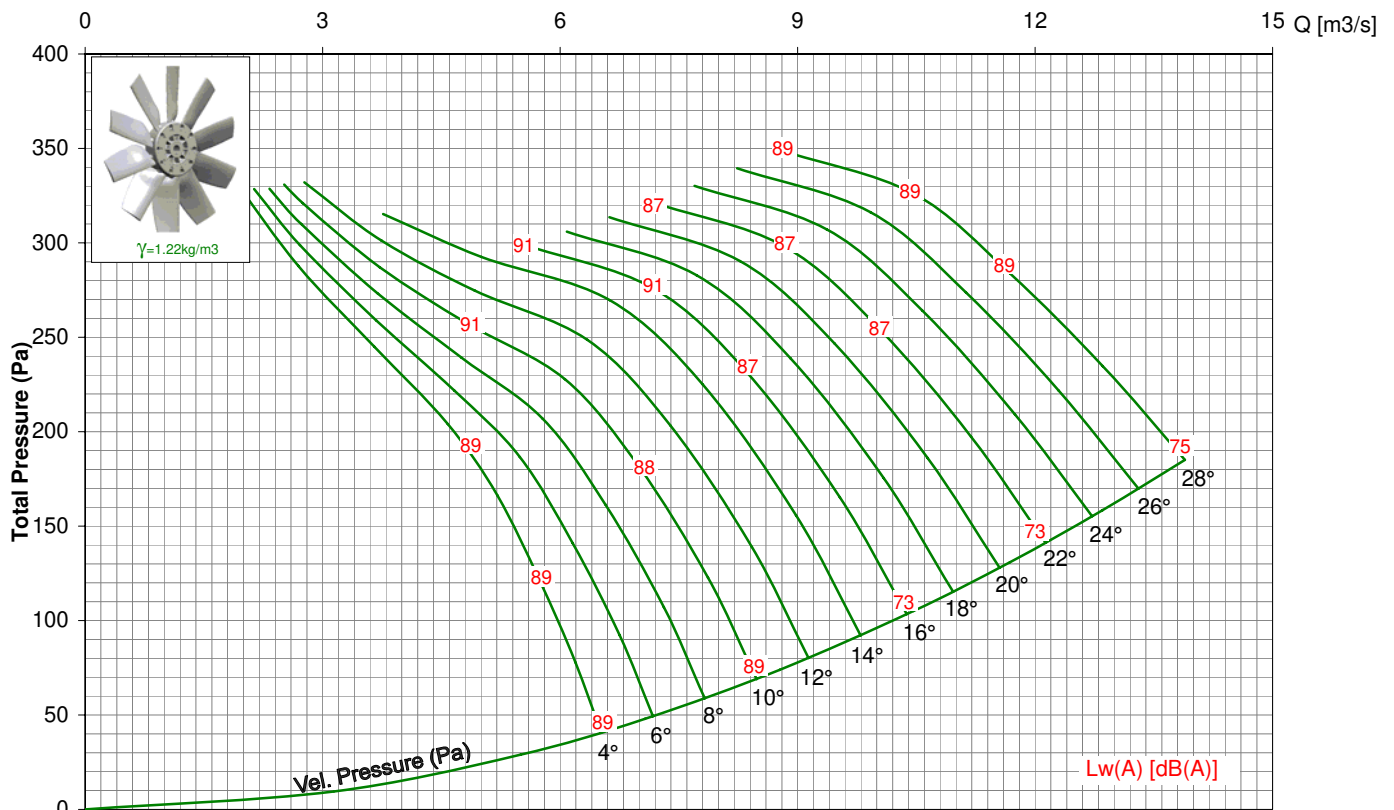

- Performance certified is for installation type D - ducted inlet, ducted outlet. Performance ratings do not include the effects of appurtenances (accessories).
- Power ratings (kW) does not include transmission losses.
- The A-weighted sound ratings shown have been calculated per AMCA Standard 301. Values shown are for inlet Lwi(A) sound power level for installation type D - ducted inlet, ducted outlet, rating include the effect of duct end correction.
- The AMCA Certified Ratings Seal applies to air performance only. dBA levels are not licensed by AMCA international.

# TDA 1000-V / 14AA/ 12-12/ \_\_ / \_ 1150rpm - 60Hz

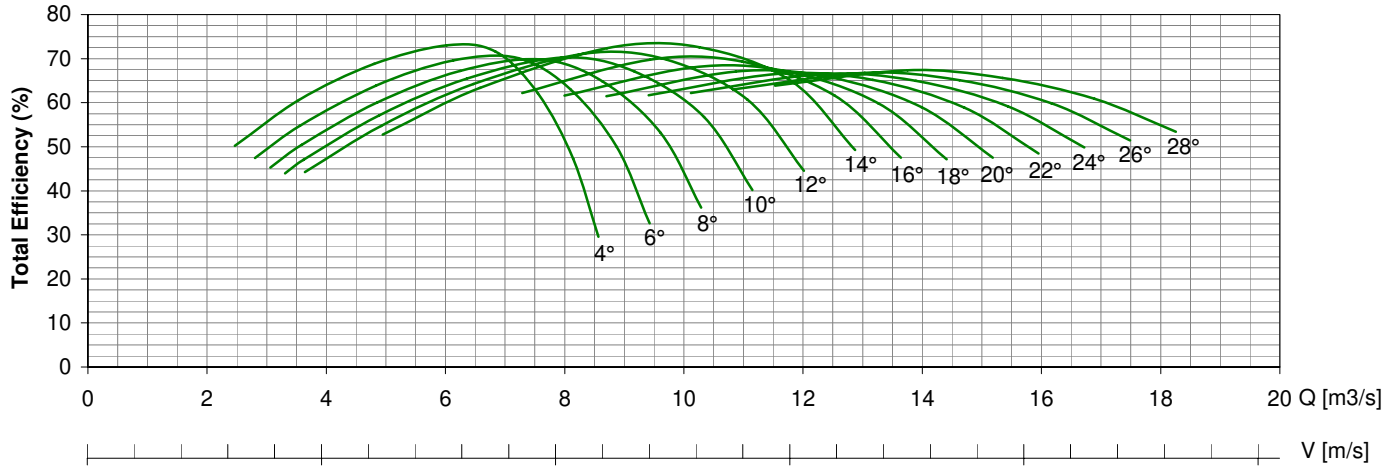
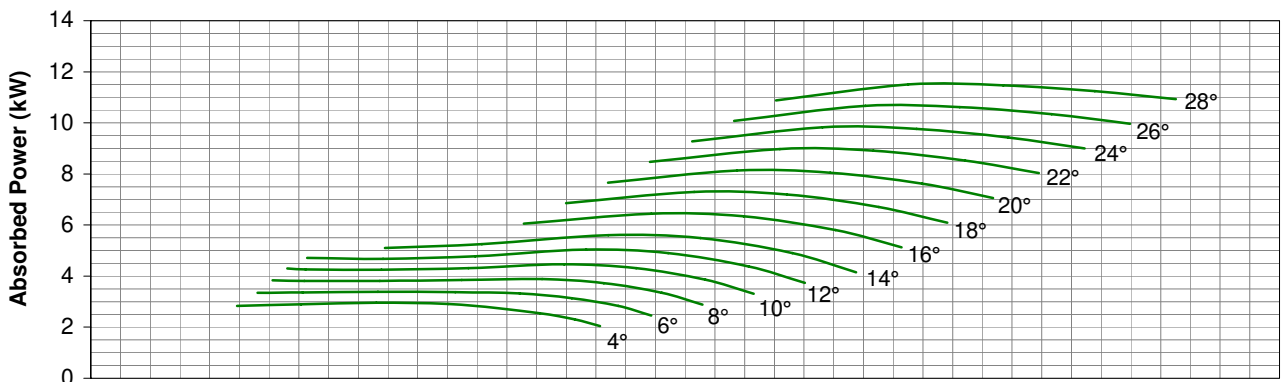
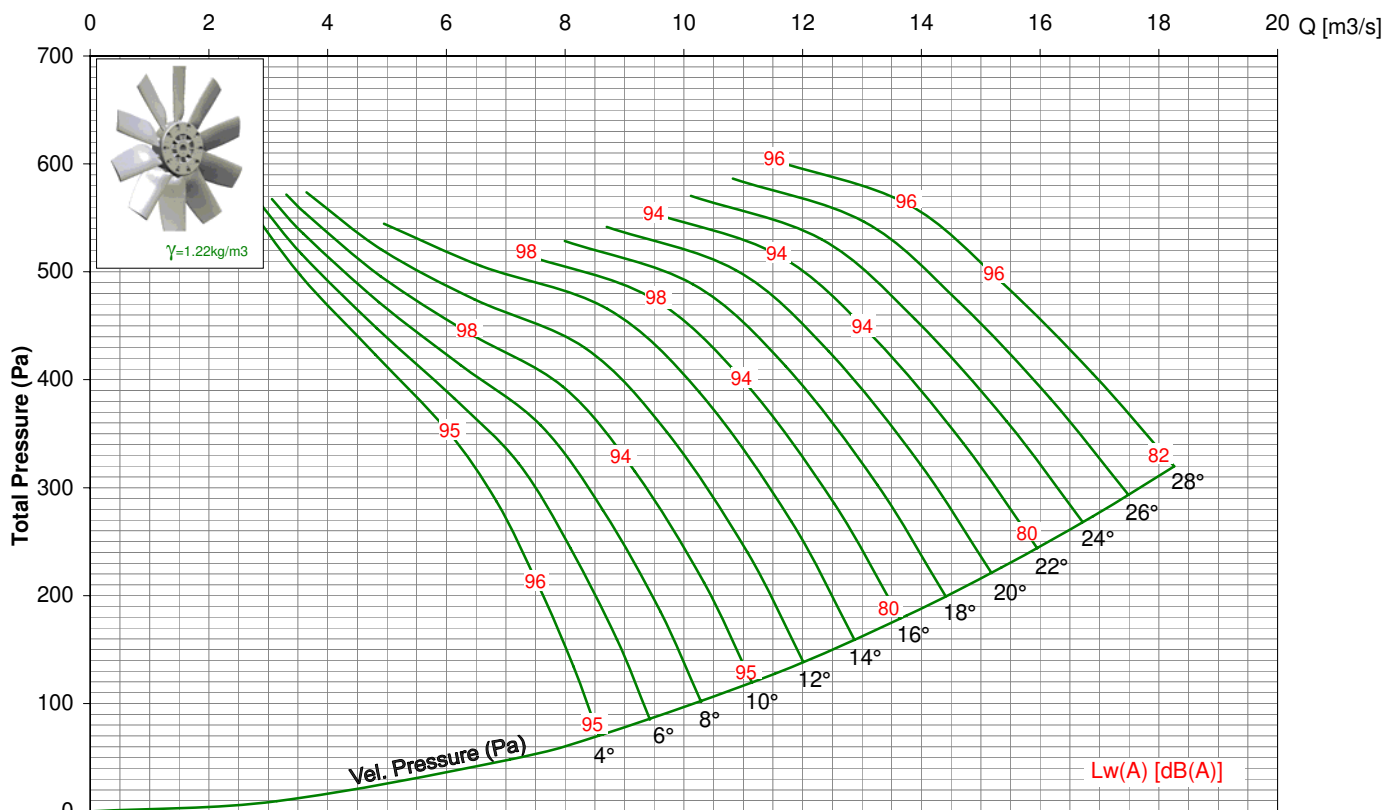

- Performance certified is for installation type D - ducted inlet, ducted outlet. Performance ratings do not include the effects of appurtenances (accessories).
- Power ratings (kW) does not include transmission losses.
- The A-weighted sound ratings shown have been calculated per AMCA Standard 301. Values shown are for inlet Lwi(A) sound power level for installation type D - ducted inlet, ducted outlet, rating include the effect of duct end correction.
- The AMCA Certified Ratings Seal applies to air performance only. dBA levels are not licensed by AMCA international.

# TDA 1000-V / 14AA/ 12-12/ \_\_ / \_ 1750rpm - 60Hz

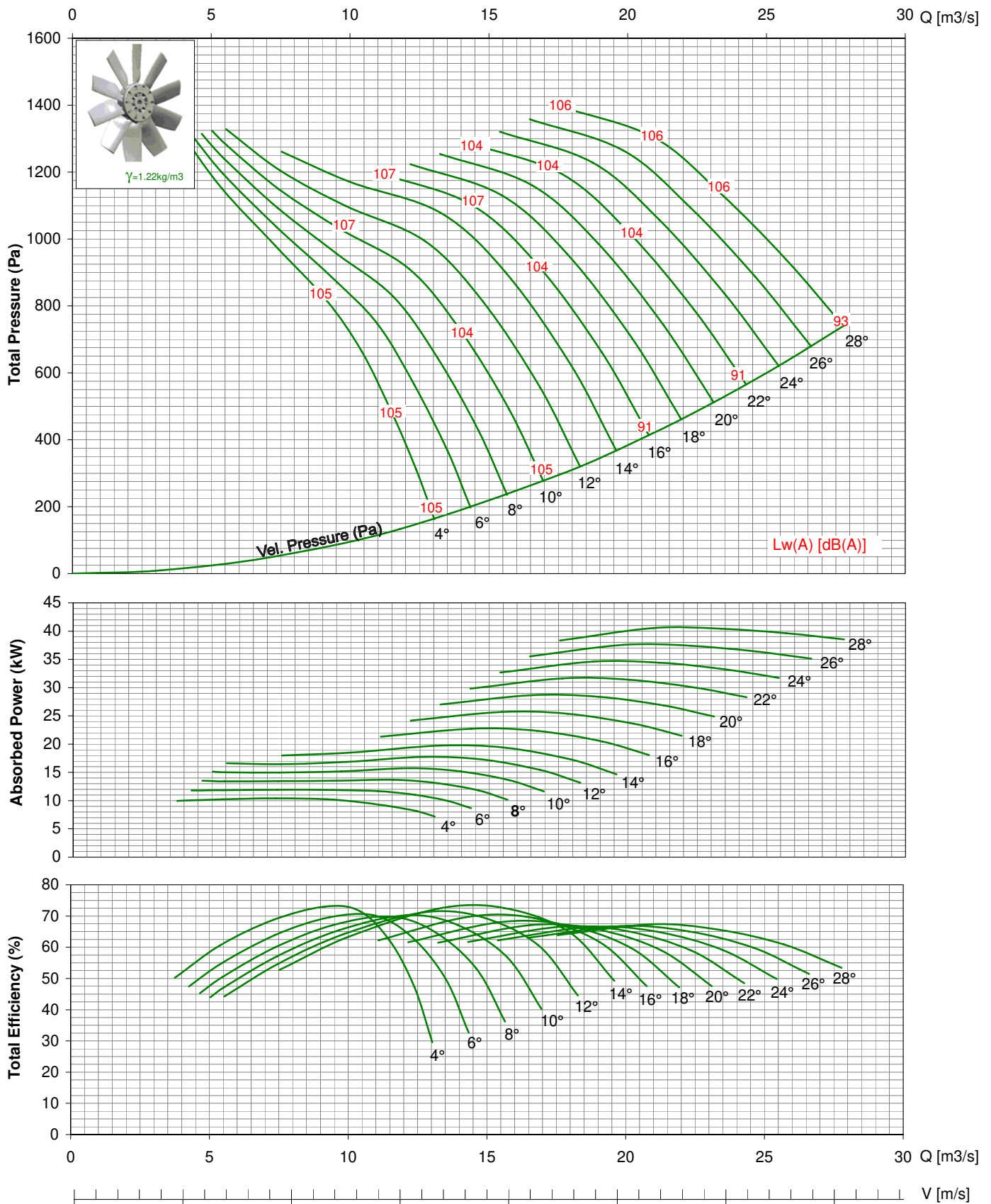

- Performance certified is for installation type D - ducted inlet, ducted outlet. Performance ratings do not include the effects of appurtenances (accessories).
- Power ratings (kW) does not include transmission losses.
- The A-weighted sound ratings shown have been calculated per AMCA Standard 301. Values shown are for inlet  $L_{wi}(A)$  sound power level for installation type D - ducted inlet, ducted outlet, rating include the effect of duct end correction.
- The AMCA Certified Ratings Seal applies to air performance only. dBA levels are not licensed by AMCA international.



# VANE AXIAL FAN DIRECT DRIVEN

## Series TDA-V



### Features

For commercial and industrial applications where large volumes of air are required at moderate to high pressure, special designed integral straightening vanes, reduced turbulence, provide high performance and low sound level.

### Construction

Double flanged casing is produced in mild steel or galvanised Steel, the impeller having manually adjustable pitch aerofoil blades is made of PPG, PAG or pressure-casted Aluminium.

### Finish

Available in standard finishes of galvanisation or painting.

### Operating Temperature

-20°C to +55°C

### Motors

Totally enclosed Class 'F' motor, to a min. IP54 protection are fitted as standard. Standard motor up to 2.2kW are usually supplied on DOL starting, motor 3.0kW and above are star/delta starting.

### Airflow Direction

Air flowing from impeller to motor is fitted as standard.



Kruger\* certifies that the TDA 1120 -V shown herein is licensed to bear the AMCA Seal. The ratings shown are based on tests and procedures performed in accordance with AMCA publication 211 and comply with the requirements of the AMCA Certified Ratings Program.

- \*Kruger Ventilation Industries Asia Co., Ltd
- \*Guangzhou Kruger Ventilation Co., Ltd
- \*Kruger Ventilation (Taiwan) Co., Ltd
- \*Kruger Ventilation Industries (Vietnam) Co., Ltd
- \*Kruger Ventilation Industries (India) Pvt. Ltd
- \*Kruger Ventilation Industries (North India) Pvt. Ltd
- \*Kruger Ventilation Industries (Thailand) Co., Ltd
- \*Kruvent Industries (M) Sdn. Bhd
- \*P.T. Kruger Ventilation Indonesia
- \*Shanghai Kruger Ventilation Co., Ltd
- \*Wuhan Kruger Ventilation Co., Ltd

## MODEL: TDA 1120-V / 14AA / 12-12 / \_ / \_ - \_ / \_

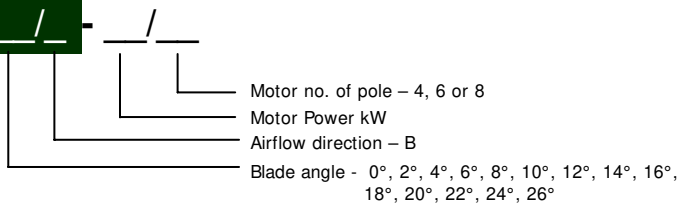

\* All Dimension in mm

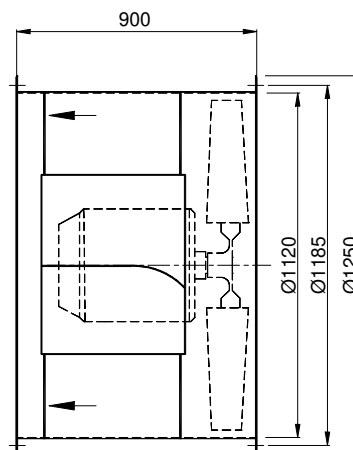
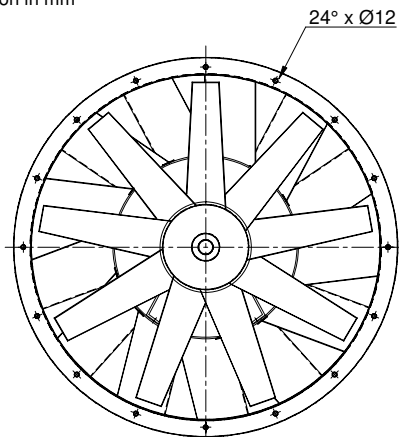

# TDA 1120-V / 14AA/ 12-12/ \_\_ / \_

## 725rpm - 50Hz

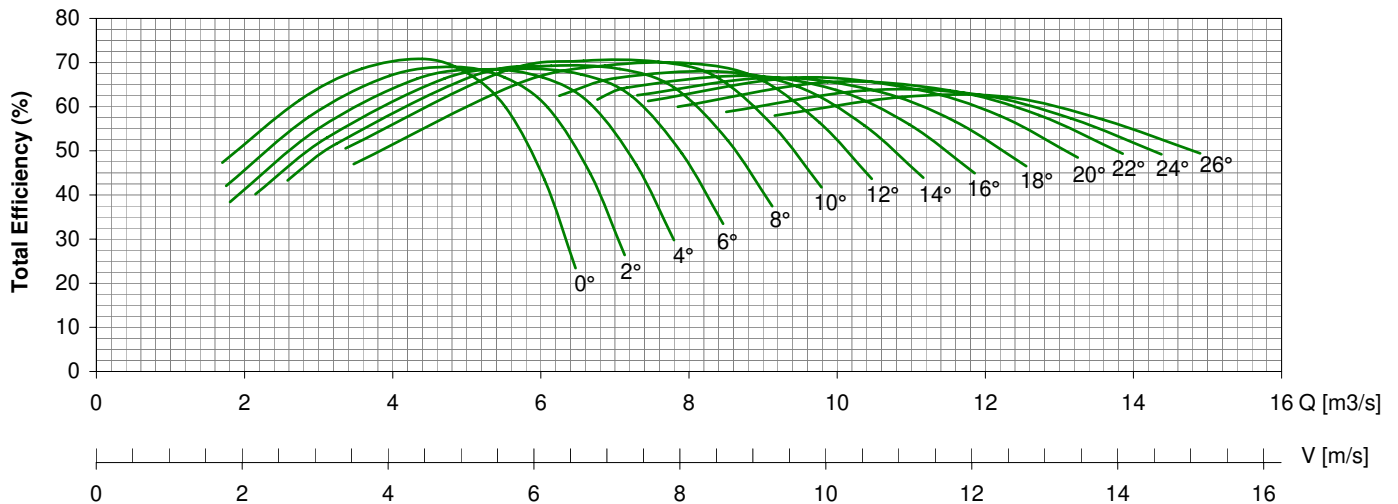
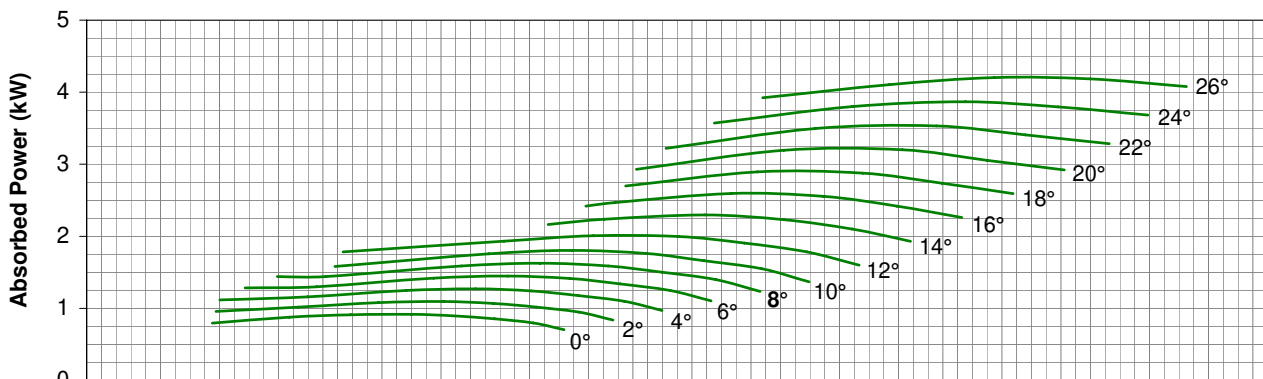
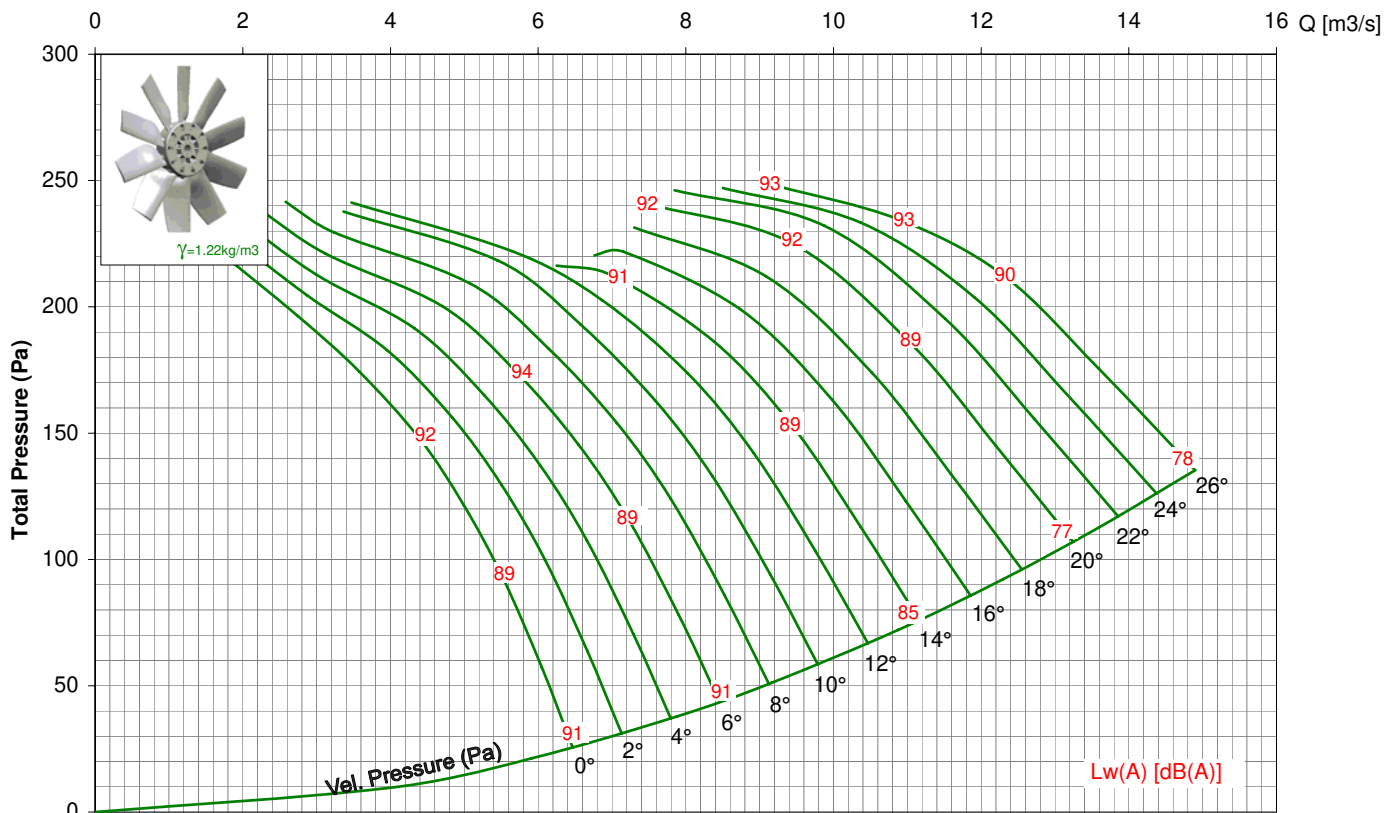

- Performance certified is for installation type D - ducted inlet, ducted outlet. Performance ratings do not include the effects of appurtenances (accessories).
- Power ratings (kW) does not include transmission losses.
- The A-weighted sound ratings shown have been calculated per AMCA Standard 301. Values shown are for inlet Lwi(A) sound power level for installation type D - ducted inlet, ducted outlet, rating include the effect of duct end correction.
- The AMCA Certified Ratings Seal applies to air performance only. dBA levels are not licensed by AMCA international.



# TDA 1120-V / 14AA/ 12-12/ \_\_ / \_

## 1450rpm - 50Hz

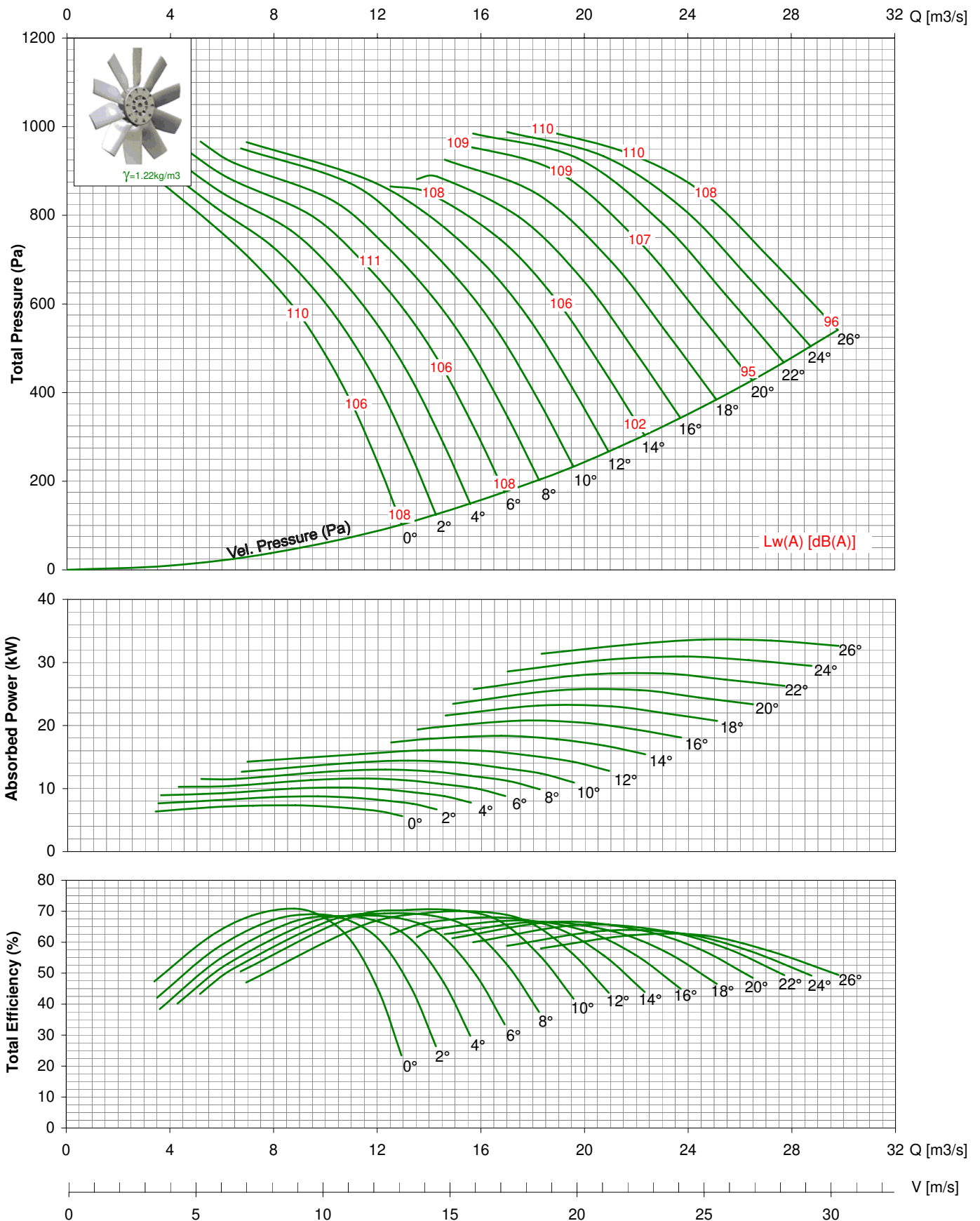

- Performance certified is for installation type D - ducted inlet, ducted outlet. Performance ratings do not include the effects of appurtenances (accessories).
- Power ratings (kW) does not include transmission losses.
- The A-weighted sound ratings shown have been calculated per AMCA Standard 301. Values shown are for inlet Lwi(A) sound power level for installation type D - ducted inlet, ducted outlet, rating include the effect of duct end correction.
- The AMCA Certified Ratings Seal applies to air performance only. dBA levels are not licensed by AMCA international.

# TDA 1120-V / 14AA/ 12-12/ \_\_ / \_ 875rpm - 60Hz

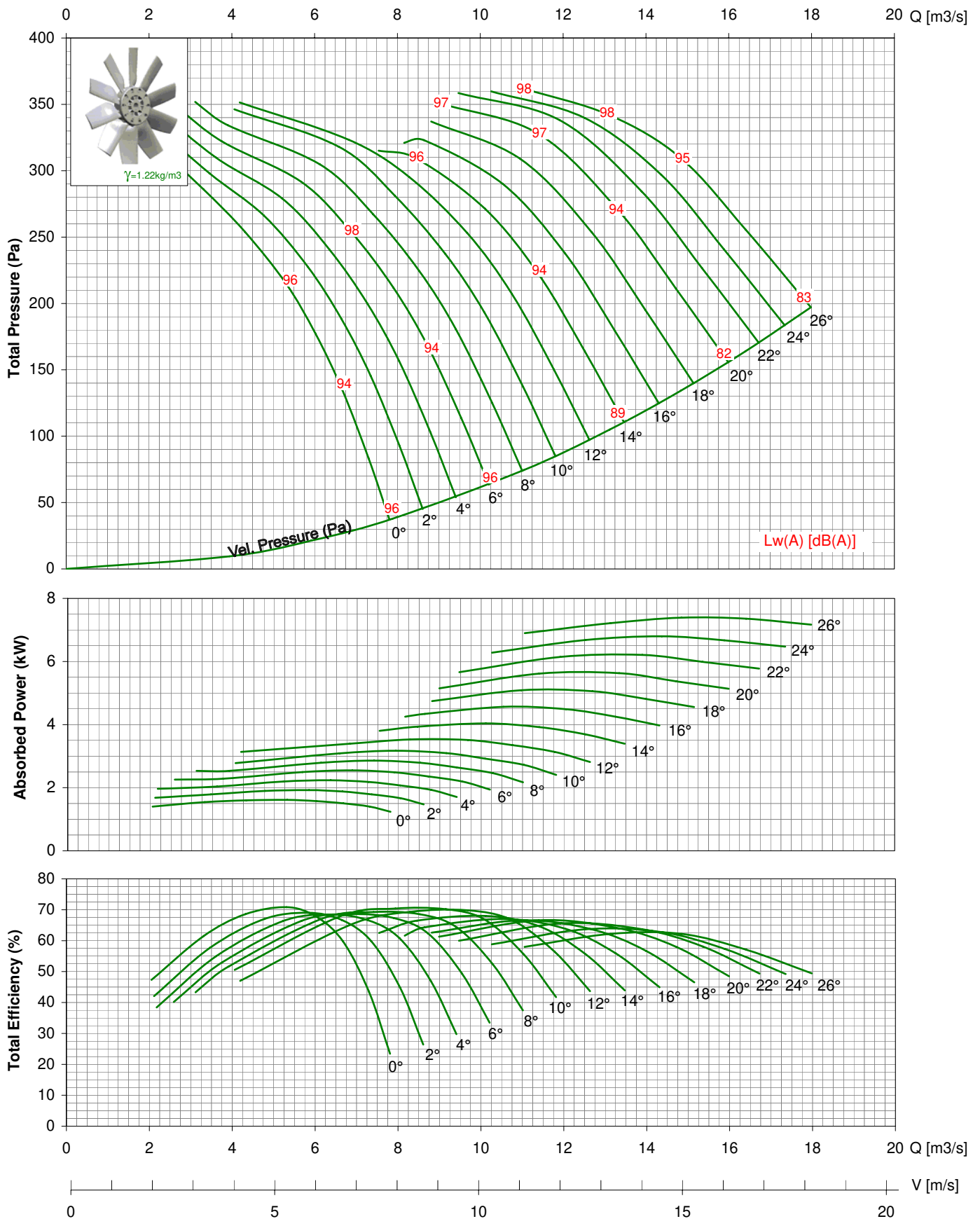

- Performance certified for installation type D - ducted inlet, ducted outlet. Performance ratings do not include the effects of appurtenances (accessories).
- Power ratings (kW) does not include transmission losses.
- The A-weighted sound ratings shown have been calculated per AMCA Standard 301. Values shown are for inlet  $L_{wi}(A)$  sound power level for installation type D - ducted inlet, ducted outlet, rating include the effect of duct end correction.
- The AMCA Certified Ratings Seal applies to air performance only. dBA levels are not licensed by AMCA international.

# TDA 1120-V / 14AA/ 12-12/ \_\_ / \_ 1150rpm - 60Hz

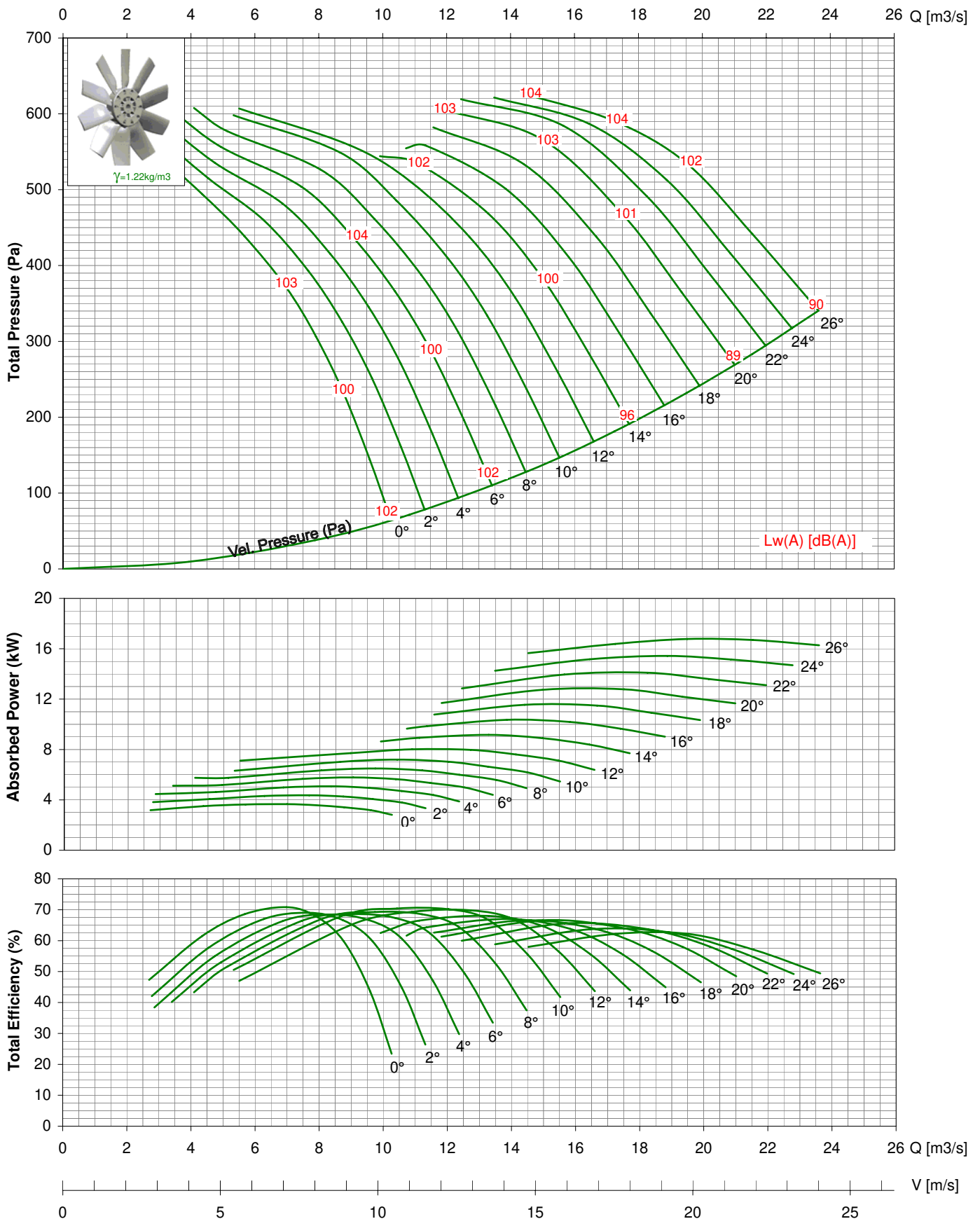

- Performance certified for installation type D - ducted inlet, ducted outlet. Performance ratings do not include the effects of appurtenances (accessories).
- Power ratings (kW) does not include transmission losses.
- The A-weighted sound ratings shown have been calculated per AMCA Standard 301. Values shown are for inlet  $L_{wi}(A)$  sound power level for installation type D - ducted inlet, ducted outlet, rating include the effect of duct end correction.
- The AMCA Certified Ratings Seal applies to air performance only. dBA levels are not licensed by AMCA international.

**ASIA PACIFIC SHENGRUI LIMITED**

Phone +00852 56261528

[info@apacfan.com](mailto:info@apacfan.com)

[www.apacfan.com](http://www.apacfan.com)

