

R2E133-BH66-14

AC centrifugal fan

backward curved, single inlet



ASIA PACIFIC SHENGRUI LIMITED

Phone +00852 56261528

info@apacfan.com

www.apacfan.com

Nominal data

Type	R2E133-BH66-14		
Motor	M2E052-BF		
Phase		1~	1~
Nominal voltage	VAC	230	230
Frequency	Hz	50	60
Type of data definition		fa	fa
Valid for approval / standard		CE	CE
Speed	min ⁻¹	2700	3200
Power input	W	25	28
Current draw	A	0.11	0.13
Motor capacitor	µF	1	1
Capacitor voltage	VDB	400	400
Capacitor standard		P0 (CE)	P0 (CE)
Min. back pressure	Pa	0	0
Min. ambient temperature	°C	-25	-25
Max. ambient temperature	°C	55	65
Starting current	A	0.2	0.21

ml = max. load · me = max. efficiency · fa = running at free air · cs = customer specs · cu = customer unit
Subject to alterations



AC centrifugal fan

backward curved, single inlet

Technical features

Mass	0.68 kg
Size	133 mm
Surface of rotor	Cast in aluminium
Material of impeller	PA plastic 6, fibreglass-reinforced
Number of blades	7
Direction of rotation	Clockwise, seen on rotor
Type of protection	IP 44; Depending on installation and position
Insulation class	"B"
Humidity class	F0
Max. permissible ambient motor temp. (transp./ storage)	+ 80 °C
Min. permissible ambient motor temp. (transp./storage)	- 40 °C
Mounting position	Any
Condensate discharge holes	None
Operation mode	S1
Motor bearing	Ball bearing
Touch current acc. IEC 60990 (measuring network Fig. 4, TN system)	< 0.75 mA
Motor protection	Thermal overload protector (TOP) wired internally
Cable exit	Variable
Protection class	I (if protective earth is connected by customer)
Product conforming to standard	EN 60335-1; CE
Approval	CCC; VDE; UL 2111; CSA C22.2 Nr.77



AC centrifugal fan

backward curved, single inlet

Product drawing

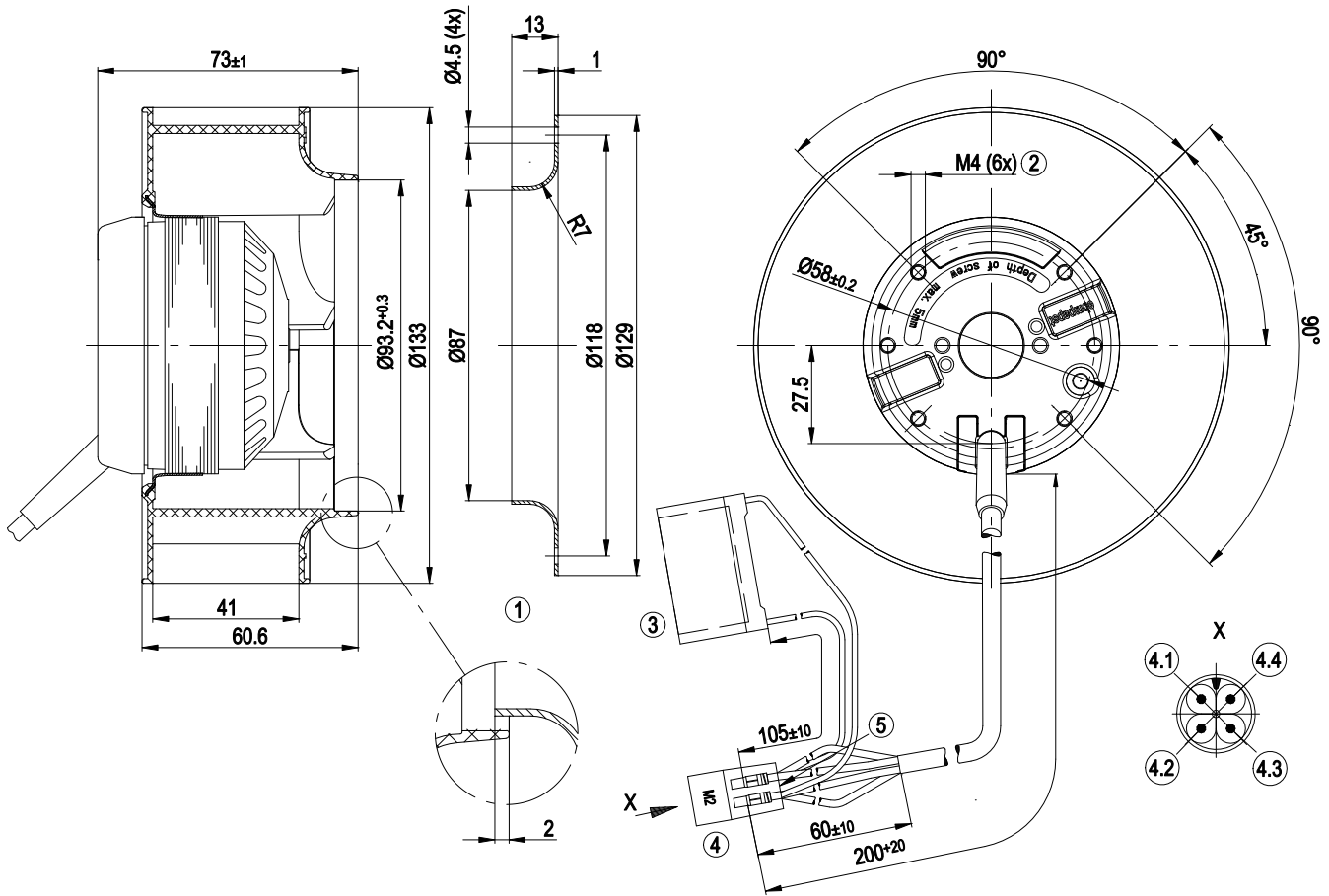

1	Accessory part: Inlet nozzle 09566-2-4013, not included in the standard scope of delivery
2	Depth of screw max. 5 mm
3	Capacitor with adhesive foil
4	Connector housing AMP 925075-0 with 2 x plug pin AMP 163555-6 and 2 x plug pin AMP 163303-8
4.1	brown (+ capacitor)
4.2	green / yellow (PE)
4.3	black (+ capacitor)
4.4	Blue
5	Connector shell, sealed



Connection screen

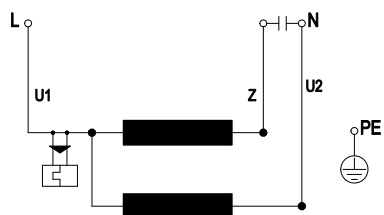

U1	blue	Z	brown	U2	black
PE	green/yellow				

Charts: Air flow 50 Hz

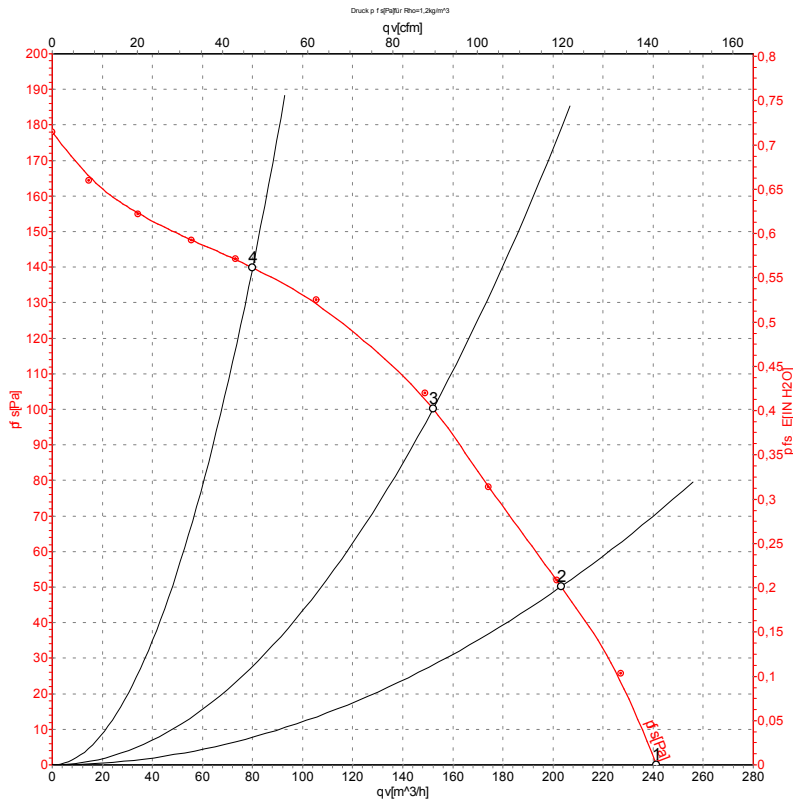

Measurement: LU-53691

Air performance measured as per ISO 5801 Installation category A. For detailed information on the measuring set-up, please contact ebm-papst. Suction-side noise levels: L_{wA} measured as per ISO 13347 / L_{pA} measured with 1m distance to fan axis. The values given are valid under the measuring conditions mentioned above and may vary according to the actual installation situation. With any deviation from the standard set-up, the specific values have to be checked and reviewed with the unit installed.

Measured values

	U	f	n	P _e	I	qv	p _{fs}
	V	Hz	min ⁻¹	W	A	m ³ /h	Pa
1	230	50	2700	25	0.11	240	0
2	230	50	2700	25	0.11	205	50
3	230	50	2695	26	0.11	150	100
4	230	50	2730	25	0.11	80	140

U = Supply voltage · f = Frequency · n = Speed · P_e = Power input · I = Current draw · qv = Air flow · p_{fs} = Pressure increase

Charts: Air flow 60 Hz

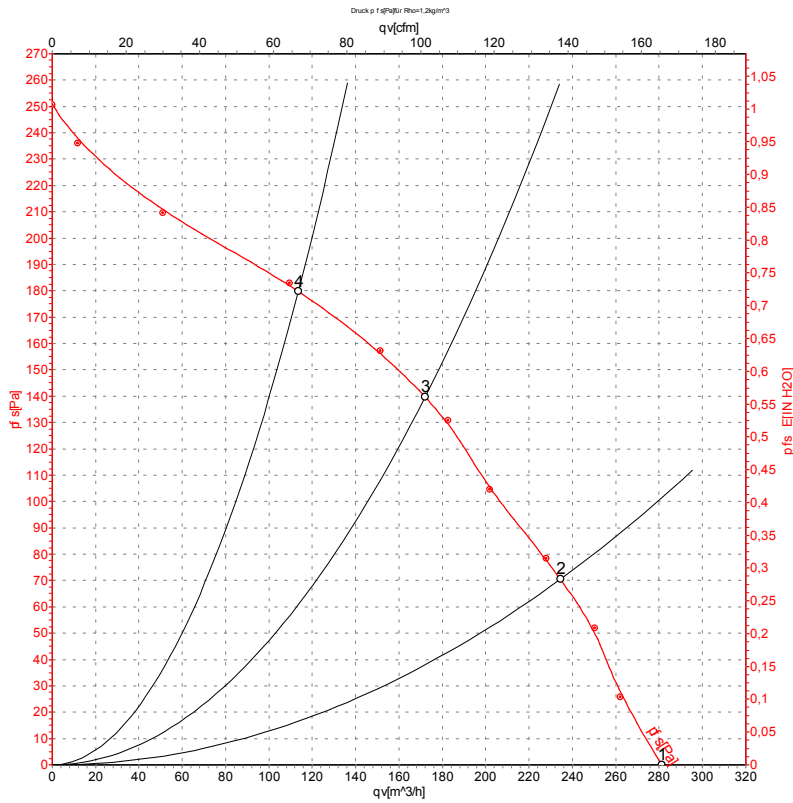

Measurement: LU-53692

Air performance measured as per ISO 5801 Installation category A. For detailed information on the measuring set-up, please contact ebm-papst. Suction-side noise levels: L_{wA} measured as per ISO 13347 / L_{pA} measured with 1m distance to fan axis. The values given are valid under the measuring conditions mentioned above and may vary according to the actual installation situation. With any deviation from the standard set-up, the specific values have to be checked and reviewed with the unit installed.

Measured values

	U	f	n	P _e	I	qv	P _{fs}
	V	Hz	min ⁻¹	W	A	m ³ /h	Pa
1	230	60	3200	28	0.13	280	0
2	230	60	3130	29	0.13	235	70
3	230	60	3125	29	0.13	170	140
4	230	60	3165	29	0.13	115	180

U = Supply voltage · f = Frequency · n = Speed · P_e = Power input · I = Current draw · qv = Air flow · p_{fs} = Pressure increase