

## ASIA PACIFIC SHENGRUI LIMITED

Phone +00852 56261528

info@apacfan.com

www.apacfan.com

## Nominal data

Type	R2E133-BH66-34		
Motor	M2E052-BF		
Phase		1~	1~
Nominal voltage	VAC	230	230
Frequency	Hz	50	60
Method of obtaining data		fa	fa
Valid for approval/standard		CE	CE
Speed (rpm)	min <sup>-1</sup>	2700	3200
Power consumption	W	25	28
Current draw	A	0.11	0.13
Capacitor	μF	1	1
Capacitor voltage	VDB	400	400
Capacitor standard		S0 (CE)	S0 (CE)
Min. back pressure	Pa	0	0
Min. back pressure	in. wg	0	0
Min. ambient temperature	°C	-25	-25
Max. ambient temperature	°C	55	65
Starting current	A	0.2	0.21

ml = Max. load · me = Max. efficiency · fa = Free air · cs = Customer specification · ce = Customer equipment  
Subject to change

### Technical description

Weight	0.7 kg
Size	133 mm
Motor size	52
Impeller material	PA plastic
Number of blades	7
Direction of rotation	Clockwise, viewed toward rotor
Degree of protection	IP44; installation- and position-dependent
Insulation class	"B"
Moisture (F) / Environmental (H) protection class	F0; H0 - dry environment
Max. permitted ambient temp. for motor (transport/storage)	+ 80 °C
Min. permitted ambient temp. for motor (transport/storage)	- 40 °C
Installation position	Any
Condensation drainage holes	On rotor side
Mode	S1
Motor bearing	Ball bearing
Touch current according to IEC 60990 (measuring circuit Fig. 4, TN system)	< 0.75 mA
Motor protection	Thermal overload protector (TOP) internally connected
With cable	Variable
Protection class	I (with customer connection of protective earth)
Motor capacitor according to EN 60252-1 in safety protection class	S0
Conformity with standards	EN 60335-1; CE
Approval	UL 1004-3; CCC; VDE; CSA C22.2 No. 77

Product drawing

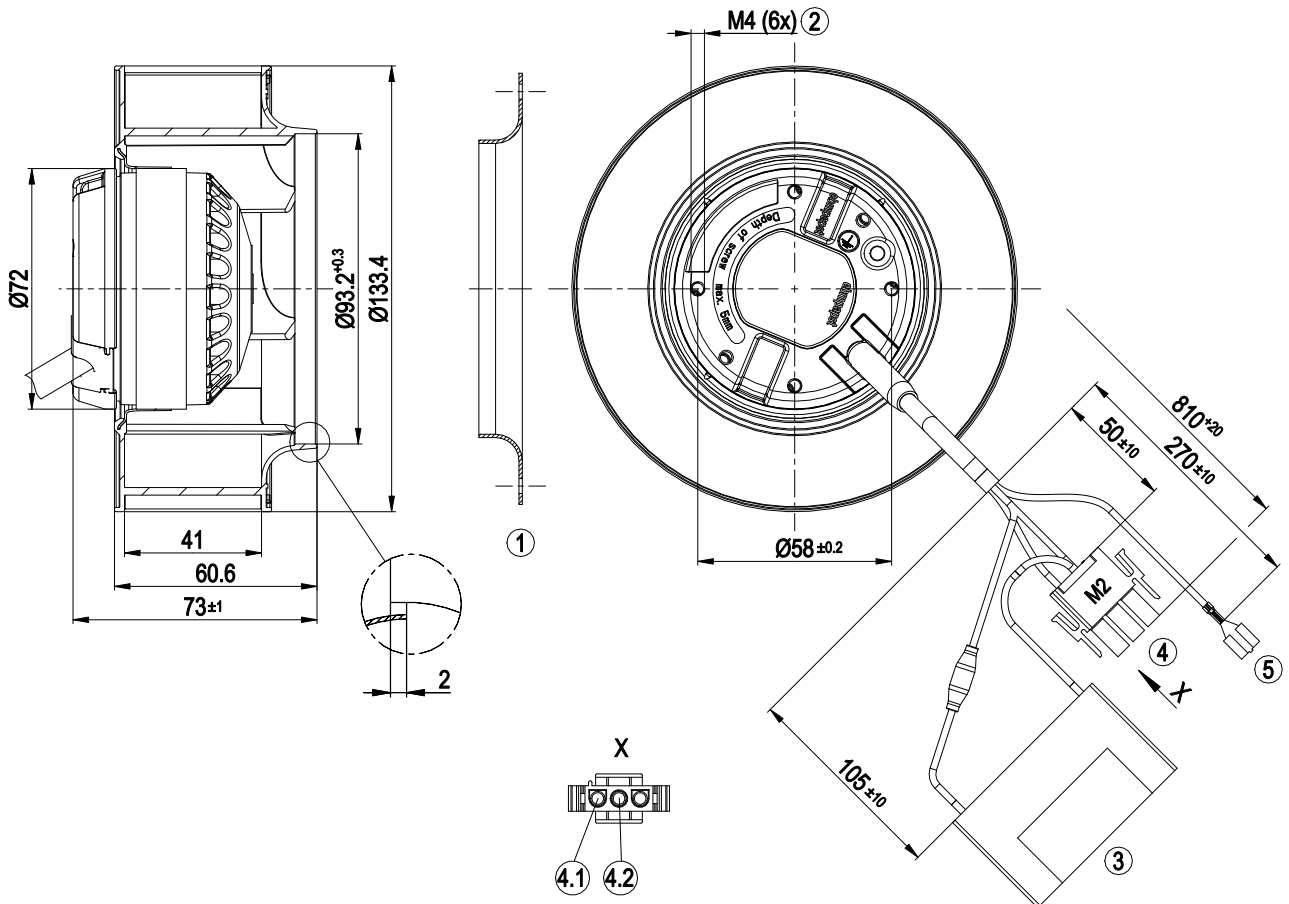

1	Accessory part: Inlet ring 09566-2-4013, not included in scope of delivery
2	Max. clearance for screw 5 mm
3	Capacitor with adhesive foil
4	Cable PVC AWG20, 3-pole connector housing tyco 2178473-3, 2x plug pin tyco 350538-1, 1x plug pin tyco 926885-1
4.1	blue
4.2	black (+ capacitor)
5	PE (green/yellow), flat push-on receptacle 6.3x0.8

## Accessory part

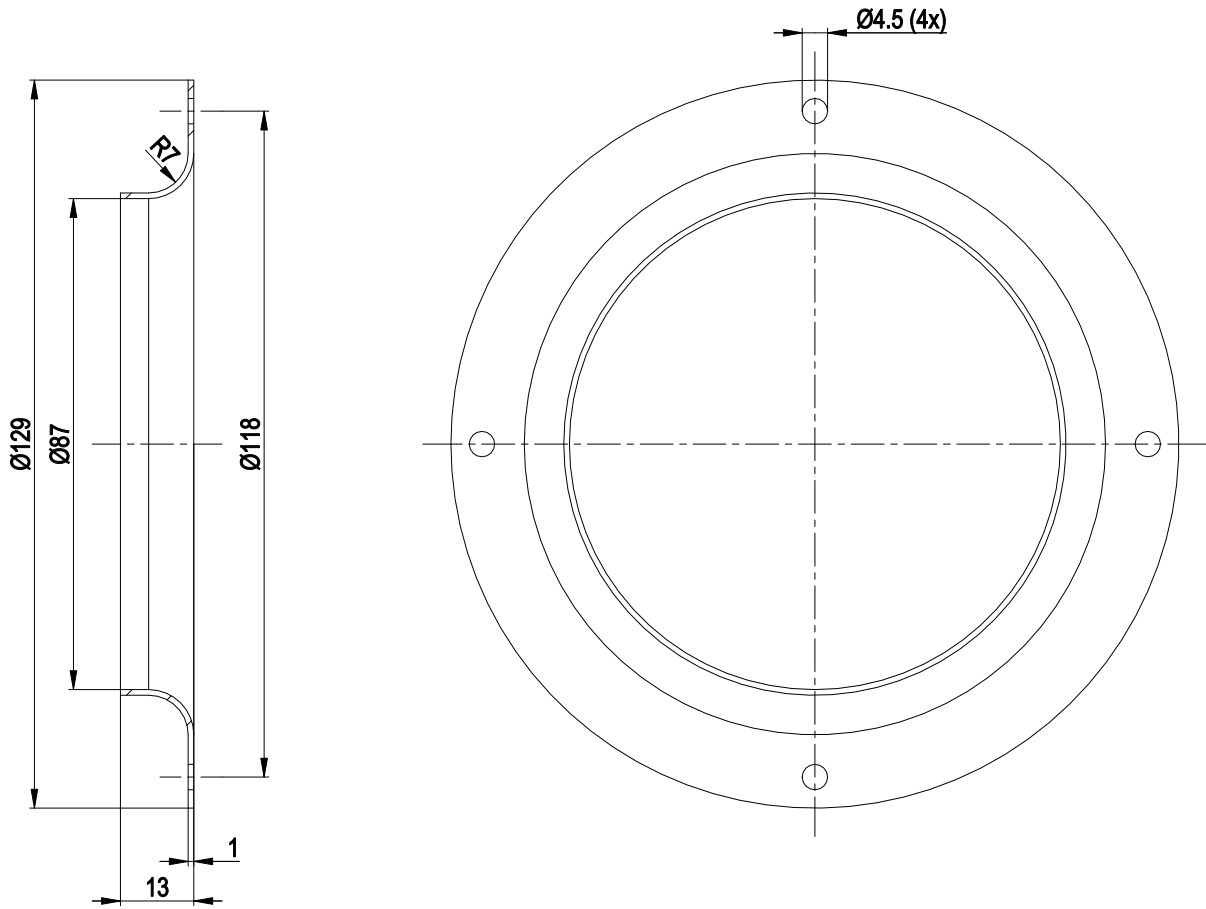

1 Accessory part: inlet ring 09566-2-4013 not included in scope of delivery

## Connection diagram

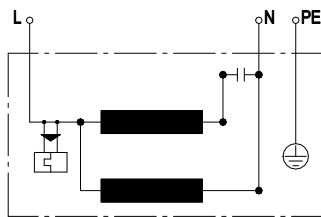

L	blue	N	black	PE	green/yellow
---	------	---	-------	----	--------------

## Curves: Air performance 50 Hz

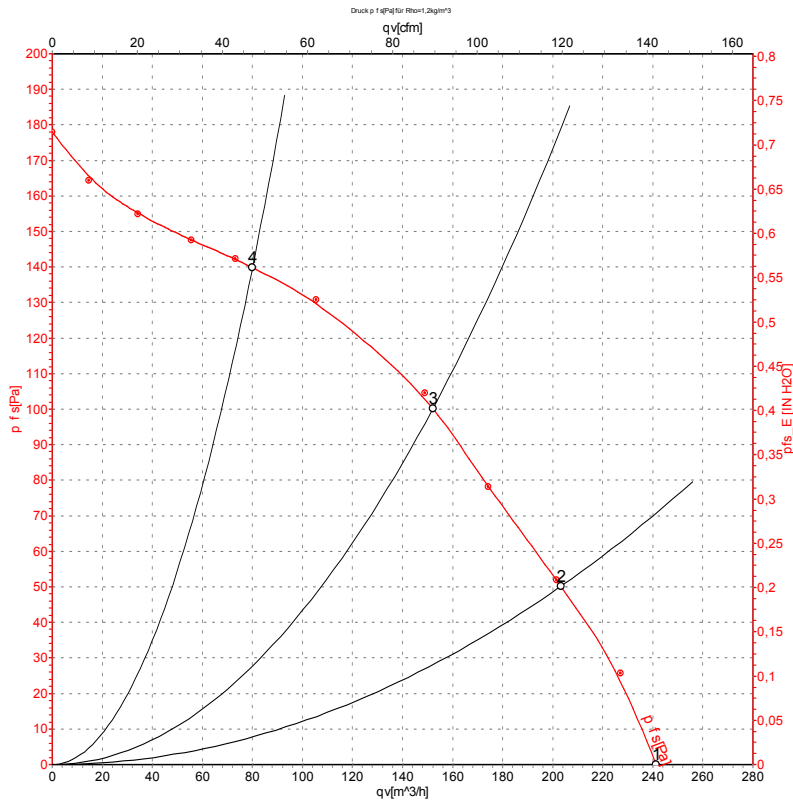

Measurement: LU-53691-1

Air performance measured according to ISO 5801 installation category A. For detailed information on the measurement setup, contact ebm-papst. Intake sound level: Sound power level according to ISO 13347 / sound pressure level measured at 1 m distance from fan axis. The values given are valid under the specified measuring conditions and may vary due to conditions of installation. For deviations from the standard configuration, the parameters have to be checked on the installed unit.

## Measured values

	U	f	n	P <sub>e</sub>	I	q <sub>V</sub>	p <sub>fs</sub>	q <sub>V</sub>	p <sub>fs</sub>
	V	Hz	min <sup>-1</sup>	W	A	m <sup>3</sup> /h	Pa	cfm	in. wg
1	230	50	2700	25	0.11	240	0	140	0.00
2	230	50	2700	25	0.11	205	50	120	0.20
3	230	50	2695	26	0.11	150	100	90	0.40
4	230	50	2730	25	0.11	80	140	45	0.56

U = Voltage · f = Frequency · n = Speed (rpm) · P<sub>e</sub> = Power consumption · I = Current draw · q<sub>V</sub> = Air flow · p<sub>fs</sub> = Pressure increase



## Curves: Air performance 60 Hz

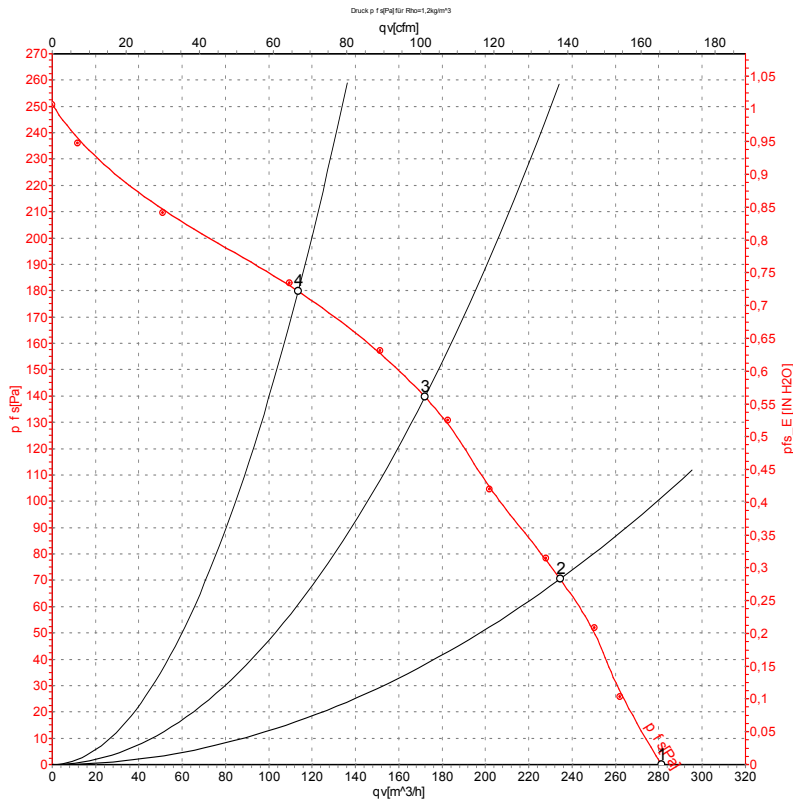

Measurement: LU-53692-1

Air performance measured according to ISO 5801 installation category A. For detailed information on the measurement setup, contact ebm-papst. Intake sound level: Sound power level according to ISO 13347 / sound pressure level measured at 1 m distance from fan axis. The values given are valid under the specified measuring conditions and may vary due to conditions of installation. For deviations from the standard configuration, the parameters have to be checked on the installed unit.

## Measured values

	U	f	n	P <sub>e</sub>	I	q <sub>V</sub>	P <sub>fs</sub>	q <sub>V</sub>	P <sub>fs</sub>
	V	Hz	min <sup>-1</sup>	W	A	m <sup>3</sup> /h	Pa	cfm	in. wg
1	230	60	3200	28	0.13	280	0	165	0.00
2	230	60	3130	29	0.13	235	70	140	0.28
3	230	60	3125	29	0.13	170	140	100	0.56
4	230	60	3165	29	0.13	115	180	65	0.72

U = Voltage · f = Frequency · n = Speed (rpm) · P<sub>e</sub> = Power consumption · I = Current draw · q<sub>V</sub> = Air flow · P<sub>fs</sub> = Pressure increase

