

backward-curved, single-intake

with support bracket

ASIA PACIFIC SHENGRUI LIMITED

Phone +00852 56261528

info@apacfan.com

www.apacfan.com

Nominal data

Type	K3G355-RT01-I3	
Motor	M3G084-GF	
Phase		1~
Nominal voltage	VAC	230
Nominal voltage range	VAC	200 .. 277
Frequency	Hz	50/60
Method of obtaining data		ml
Speed (rpm)	min ⁻¹	2100
Power consumption	W	750
Current draw	A	3.3
Min. ambient temperature	°C	-40
Max. ambient temperature	°C	55

ml = Max. load · me = Max. efficiency · fa = Free air · cs = Customer specification · ce = Customer equipment
Subject to change

Data according to Commission Regulation (EU) 327/2011 (EN 17166)

		Actual	Req. 2015			
01 Overall efficiency η_{es}	%	66	50.2	09 Power consumption P_{ed}	kW	0.75
02 Measurement category		A		09 Air flow q_v	m ³ /h	3205
03 Efficiency category		Static		09 Pressure increase p_{fs}	Pa	511
04 Efficiency grade N		77.8	62	10 Speed (rpm) n	min ⁻¹	2100
05 Variable speed drive		Yes		11 Specific ratio*		1.01

Data obtained at optimum efficiency level.

The ErP data is determined using a motor-impeller combination in a standardized measurement setup.

* Specific ratio = $1 + p_{fs} / 100\,000\text{ Pa}$

LU-150482



Technical description

Weight	15.1 kg
Size	355 mm
Motor size	84
Rotor surface	Painted black
Electronics housing material	Die-cast aluminum
Impeller material	PA plastic
Support plate material	Sheet steel, galvanized
Support bracket material	Steel, painted black
Inlet nozzle material	Sheet steel, galvanized
Number of blades	6
Direction of rotation	Clockwise, viewed toward rotor
Degree of protection	IP55
Insulation class	"F"
Moisture (F) / Environmental (H) protection class	H1
Ambient temperature note	Occasional start-up at temperatures between -40°C and -25°C is permitted. For continuous operation at ambient temperatures below -25°C (such as refrigeration applications), use must be made of a fan design with special low-temperature bearings.
Max. permitted ambient temp. for motor (transport/storage)	+80 °C
Min. permitted ambient temp. for motor (transport/storage)	-40 °C
Installation position	Shaft horizontal or rotor on bottom; rotor on top on request
Condensation drainage holes	On rotor side
Mode	S1
Motor bearing	Ball bearing
Technical features	<ul style="list-style-type: none"> - Output 10 VDC, max. 10 mA - Operation and alarm display - Alarm relay - Integrated PID controller - Power limiter - Motor current limitation - PFC, active - RS-485 MODBUS-RTU - Soft start - Control input 0-10 VDC / PWM - Control interface with SELV potential safely disconnected from the mains - Thermal overload protection for electronics/motor - Line undervoltage / phase failure detection
EMC immunity to interference	According to EN 61000-6-2 (industrial environment)
EMC circuit feedback	According to EN 61000-3-2/3
EMC interference emission	According to EN 61000-6-3 (household environment)
Touch current according to IEC 60990 (measuring circuit Fig. 4, TN system)	<= 3.5 mA
Motor protection	Thermal overload protector (TOP) internally connected
With cable	Variable
Protection class	I (with customer connection of protective earth)
Conformity with standards	EN 61800-5-1; EN 60335-1; CE

K3G355-RT01-I3

EC centrifugal module - RadiCal

backward-curved, single-intake

with support bracket

Approval

UL 1004-7 + 60730-1; EAC; CSA C22.2 No. 77 + CAN/CSA-E60730-1



Product drawing

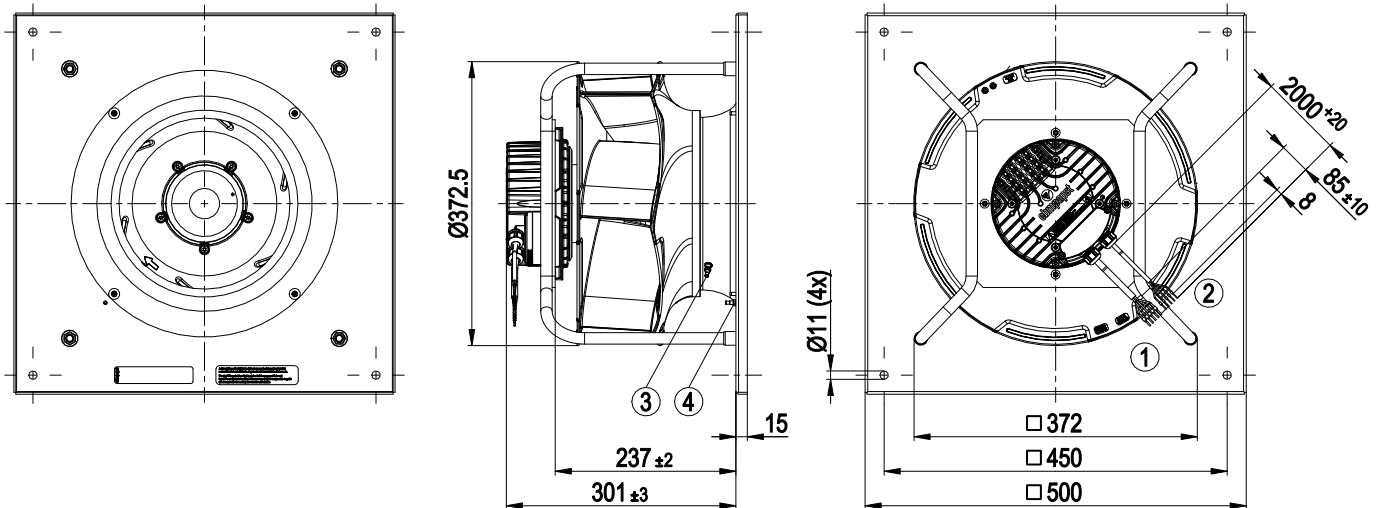

1	Cable PVC AWG18 5x wire-end ferrule
2	Cable PVC AWG22 5x wire-end ferrule
3	Inlet ring with pressure tap (k-factor: 128)
4	Flange plate with pressure tap

EC centrifugal module - RadiCal

backward-curved, single-intake
with support bracket

Connection diagram

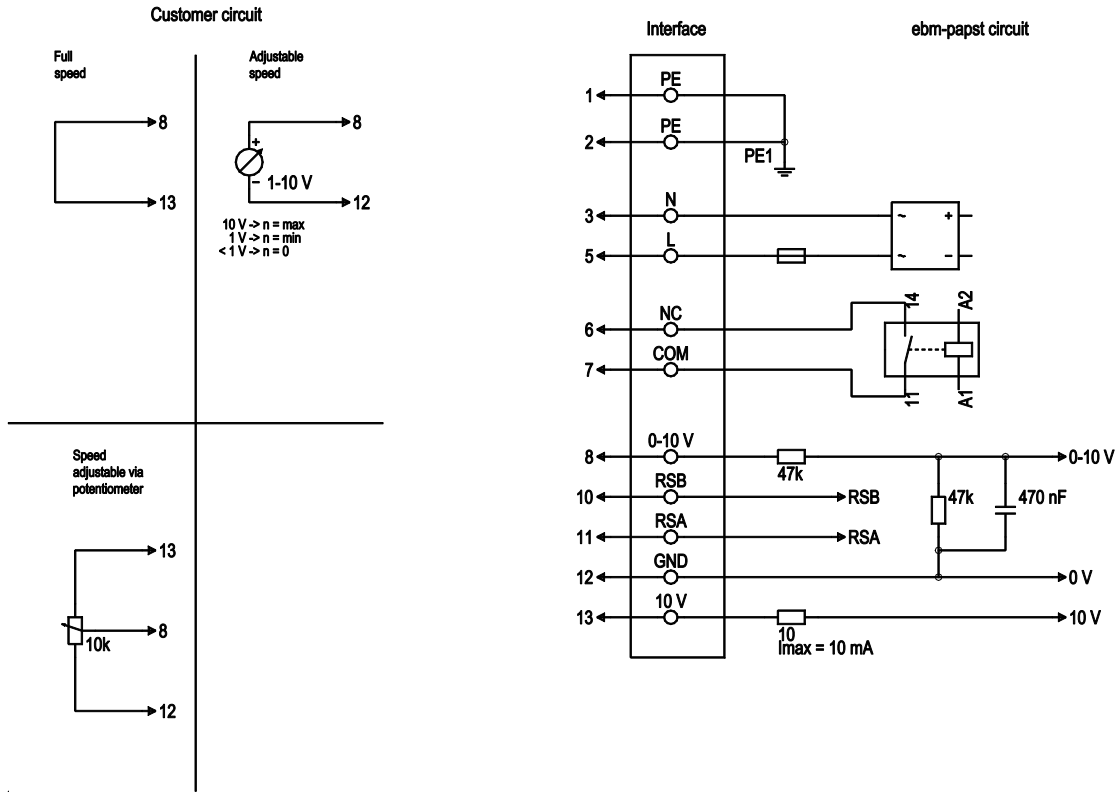

No.	Conn.	Designation	Color	Function/assignment
1	1, 2	PE	green/yellow	Protective earth
1	3	N	blue	Power supply, neutral conductor, 50/60 Hz
1	5	L	black	Power supply, phase, 50/60 Hz
1	6	NC	white 1	Status relay, floating status contact; break for failure, contact rating 250 VAC / 2A (AC1) / min. 10 mA, basic insulation on supply side and reinforced insulation on control interface side
1	7	COM	white 2	Status relay, floating status contact; common connection, contact rating 250 VAC / 2A (AC1) / min. 10 mA, basic insulation on supply side and reinforced insulation on control interface side
2	8	0-10V	yellow	Analog input (set value); 0-10 V; Ri = 100 kΩ; adjustable curve
2	10	RSB	brown	RS485 interface for MODBUS, RSB
2	11	RSA	white	RS485 interface for MODBUS, RSA
2	12	GND	blue	Reference ground for control interface, SELV
2	13	+10V	red	Fixed voltage output 10 VDC, +10 V ±3%; max. 10 mA; short-circuit-proof; power supply for external devices (e.g. pot)



Curves: Air performance 50 Hz

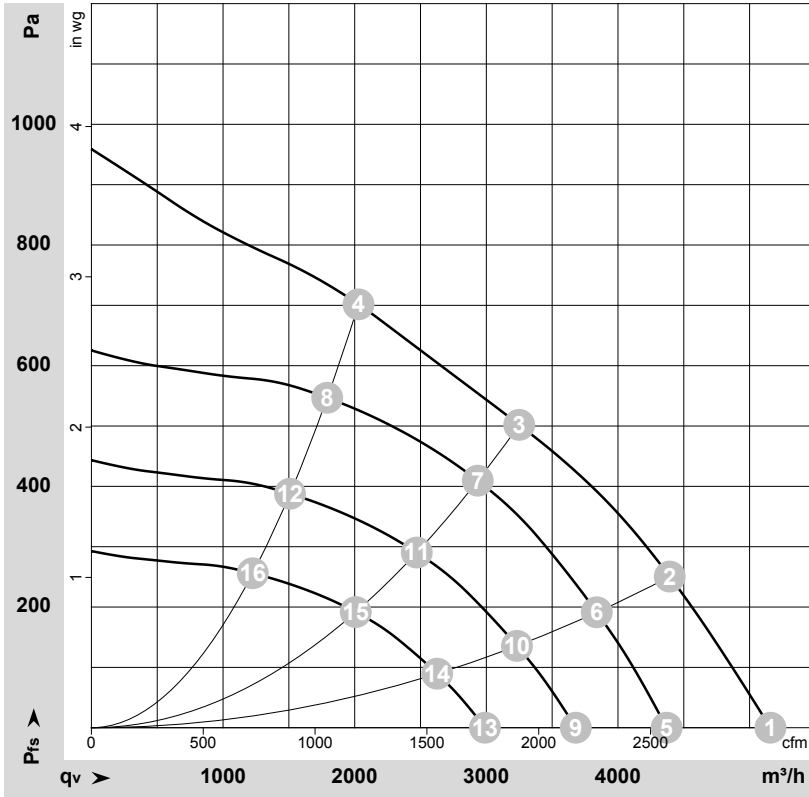

$\rho = 1.15 \text{ kg/m}^3 \pm 2 \%$

Measurement: LU-150482-1

Air performance measured according to ISO 5801 installation category A. For detailed information on the measurement setup, contact ebmpapst. Intake sound level: Sound power level according to ISO 13347 / sound pressure level measured at 1 m distance from fan axis. The values given are valid under the specified measuring conditions and may vary due to conditions of installation. For deviations from the standard configuration, the parameters have to be checked on the installed unit.

Measured values

	U	f	n	P _{ed}	I	LpA _{in}	LwA _{in}	q _v	P _{fs}	q _v	P _{fs}
	V	Hz	min ⁻¹	W	A	dB(A)	dB(A)	m ³ /h	Pa	cfm	in. wg
1	230	50	2245	627	2.76	80	87	5160	0	3035	0.00
2	230	50	2175	750	3.30	75	82	4395	250	2585	1.00
3	230	50	2100	750	3.30	67	74	3250	500	1915	2.01
4	230	50	2155	750	3.30	68	76	2030	700	1195	2.81
5	230	50	1900	381	1.68	75	82	4370	0	2570	0.00
6	230	50	1900	502	2.20	72	79	3840	193	2260	0.77
7	230	50	1900	558	2.45	64	71	2935	410	1725	1.65
8	230	50	1900	518	2.28	65	73	1790	547	1055	2.20
9	230	50	1600	227	1.00	71	78	3680	0	2165	0.00
10	230	50	1600	300	1.32	67	74	3235	137	1905	0.55
11	230	50	1600	333	1.46	60	67	2470	291	1455	1.17
12	230	50	1600	309	1.36	61	69	1510	388	890	1.56
13	230	50	1300	122	0.54	66	73	2990	0	1760	0.00
14	230	50	1300	161	0.71	62	69	2625	90	1545	0.36
15	230	50	1300	179	0.79	55	62	2010	192	1180	0.77
16	230	50	1300	166	0.73	56	63	1225	256	720	1.03

U = Voltage · f = Frequency · n = Speed (rpm) · P_{ed} = Power consumption · I = Current draw · LpA_{in} = Sound pressure level intake side · LwA_{in} = Sound power level intake side
q_v = Air flow · P_{fs} = Pressure increase

