

G1G133-DK23-28

EC centrifugal fan

forward-curved, single-intake
with housing (without flange)

ASIA PACIFIC SHENGRUI LIMITED

Phone +00852 56261528

info@apacfan.com

www.apacfan.com

Nominal data

Type	G1G133-DK23-28	
Motor	M1G055-BI	
Phase		1~
Nominal voltage	VAC	230
Frequency	Hz	50/60
Method of obtaining data		ml
Speed (rpm)	min ⁻¹	2400
Power consumption	W	35
Current draw	A	0.28
Min. back pressure	Pa	190
Min. back pressure	in. wg	0.76
Min. ambient temperature	°C	-20
Max. ambient temperature	°C	55

ml = Max. load · me = Max. efficiency · fa = Free air · cs = Customer specification · ce = Customer equipment
Subject to change

EC centrifugal fan

forward-curved, single-intake
with housing (without flange)

Technical description

Size	133 mm
Motor size	55
Rotor surface	Thick-film passivated
Impeller material	Sheet steel, galvanized
Housing material	Sheet steel, galvanized
Direction of rotation	Clockwise, viewed toward rotor
Degree of protection	IP54
Insulation class	"B"
Moisture (F) / Environmental (H) protection class	H1
Max. permitted ambient temp. for motor (transport/storage)	+ 80 °C
Min. permitted ambient temp. for motor (transport/storage)	- 40 °C
Installation position	Any
Condensation drainage holes	None, open rotor
Mode	S1
Motor bearing	Ball bearing
Technical features	<ul style="list-style-type: none"> - Speed setting input (230 V) - ESM+ expandable with plug-in module - Soft start - Thermal overload protection for motor
EMC immunity to interference	According to EN 61000-6-2 (industrial environment)
EMC circuit feedback	According to EN 61000-3-2/3
EMC interference emission	According to EN 61000-6-3 (household environment)
Touch current according to IEC 60990 (measuring circuit Fig. 4, TN system)	<= 0.25 mA
Electrical hookup	Connector with cable
Motor protection	Thermal switch auto reset, internally connected
With cable	Lateral
Protection class assignment	<p>I; If a protective earth is connected by the customer</p> <p>This component for installation may have several local protection classes. This information relates to this component's basic design.</p> <p>The final protection class is based on the component's intended installation and connection.</p>
Safety class of the permissible refrigerants according to EN378 / ISO5149-1	A3/B3
Maximum surface temperature	225 °C
Conformity with standards	EN 60034-1; EN 60204-1; EN 60335-1; EN 60335-2-24; EN 60335-2-89; CE
Comment on CE	Ecodesign Directive 2009/125/EC + Fan Directive (EC) No. 327/2011 does not apply, as power consumption <125W.
Approval	CSA C22.2 No. 77; UL 1004-3

EC centrifugal fan

forward-curved, single-intake
with housing (without flange)

Product drawing

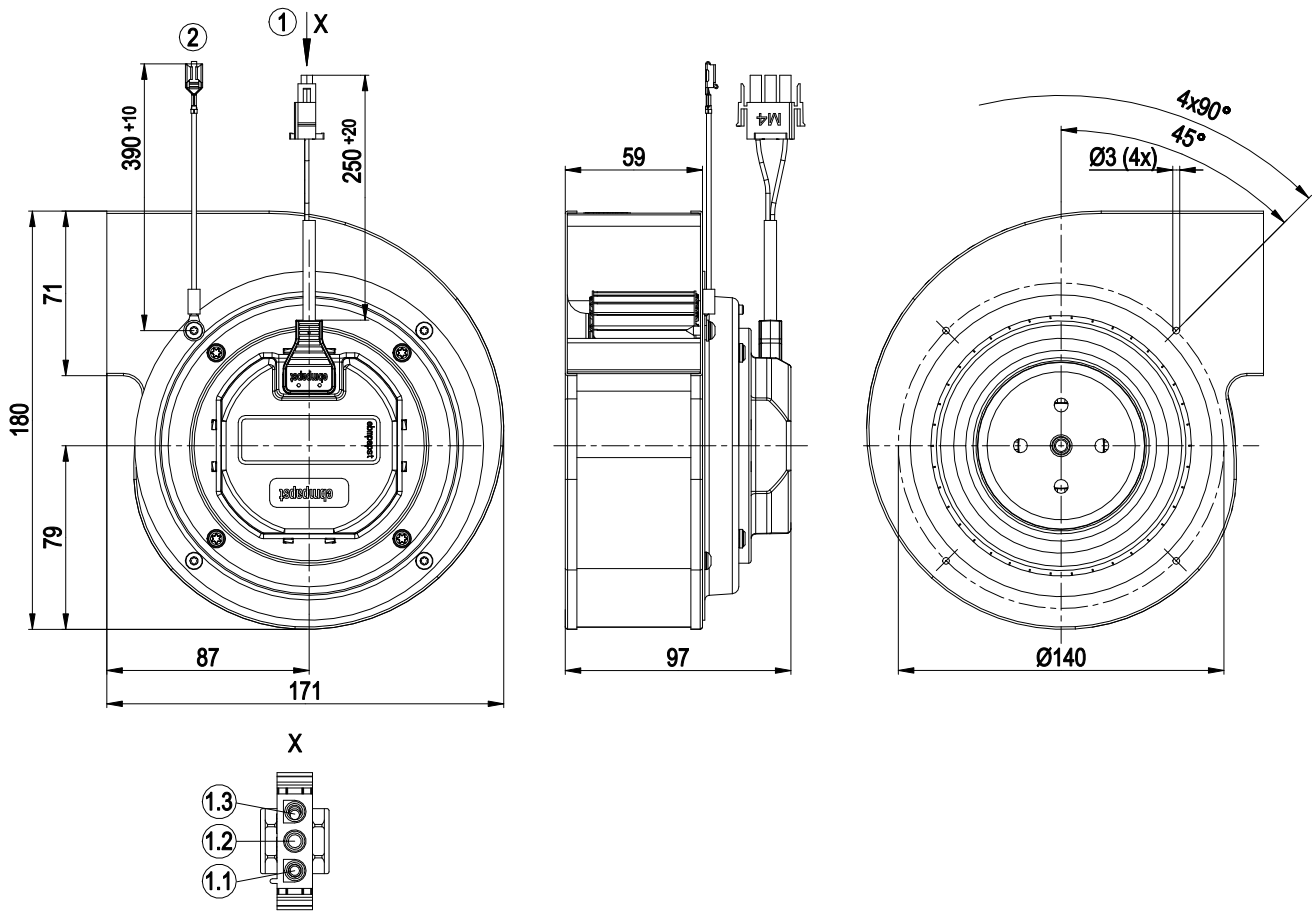

1	Cable PVC AWG20 3-pole connector housing TE 2178473-3, 2x plug pin TE 926885-1
1.1	L
1.2	not used
1.3	N
2	Cable PVC AWG20 1x flat push-on receptacle 6.3x0.8 (PE)

Connection diagram

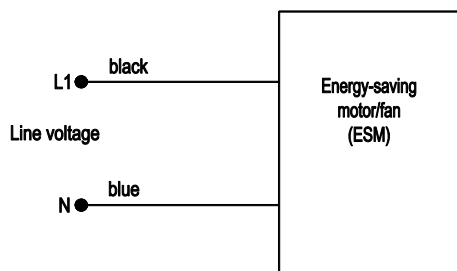

EC centrifugal fan

forward-curved, single-intake
with housing (without flange)

Curves: Air performance 50 Hz

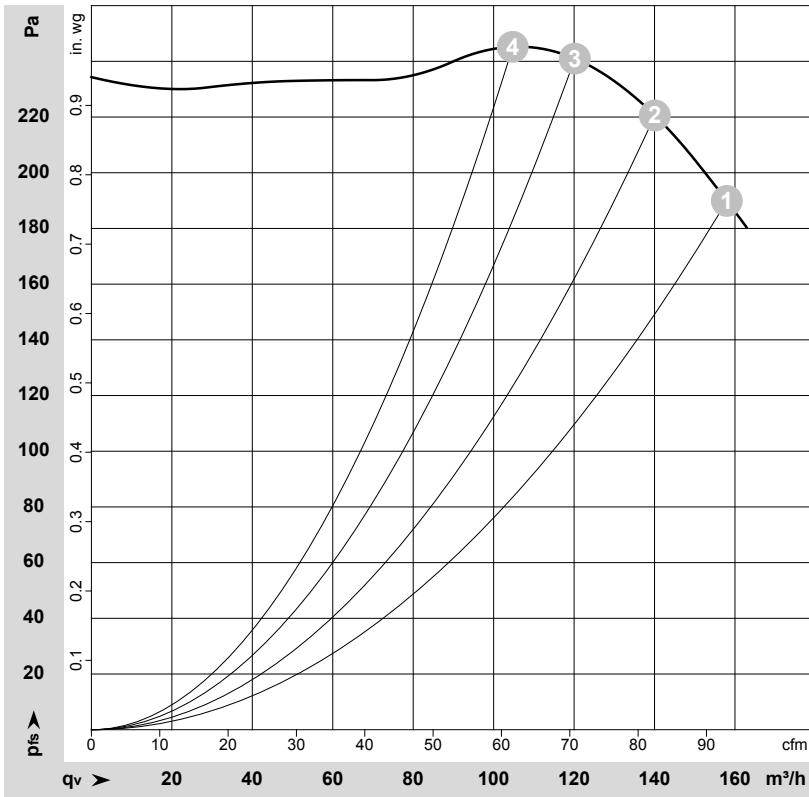

$\rho = 1.15 \text{ kg/m}^3 \pm 2 \%$

Measurement: LU-208677-1
Date: 2020-09-18

Air performance measured according to ISO 5801 installation category A. For detailed information on the measurement setup, contact ebm-papst. Intake sound level: Sound power level according to ISO 13347 / sound pressure level measured at 1 m distance from fan axis. The values given are valid under the specified measuring conditions and may vary due to conditions of installation. For deviations from the standard configuration, the parameters have to be checked on the installed unit.

Measured values

	Wired	U	f	n	P _{ed}	I	q _v	p _{fs}	q _v	p _{fs}
		V	Hz	min ⁻¹	W	A	m ³ /h	Pa	cfm	in. wg
1	1~	230	50	2400	35	0.28	160	190	95	0.76
2	1~	230	50	2400	30	0.24	140	220	80	0.88
3	1~	230	50	2400	25	0.21	120	240	70	0.96
4	1~	230	50	2400	22	0.19	105	245	60	0.98

Wired = Wiring · U = Voltage · f = Frequency · n = Speed (rpm) · P_{ed} = Power consumption · I = Current draw · q_v = Air flow · p_{fs} = Pressure increase