

R1G175-RB33-10

# EC centrifugal fan

backward-curved, single-intake

## ASIA PACIFIC SHENGRUI LIMITED

Phone +00852 56261528

info@apacfan.com

www.apacfan.com

### Nominal data

Type	R1G175-RB33-10	
Motor	M1G055-BI	
Nominal voltage	VDC	48
Nominal voltage range	VDC	36 .. 60
Method of obtaining data		fa
Speed (rpm)	min <sup>-1</sup>	3950
Power consumption	W	75
Current draw	A	1.85
Min. ambient temperature	°C	-25
Max. ambient temperature	°C	70

ml = Max. load · me = Max. efficiency · fa = Free air · cs = Customer specification · ce = Customer equipment  
Subject to change



## Technical description

<b>Weight</b>	0.94 kg
<b>Fan size</b>	175 mm
<b>Rotor surface</b>	Painted black
<b>Electronics housing material</b>	Die-cast aluminum, painted black
<b>Impeller material</b>	PA66 plastic, sheet-metal plate painted black
<b>Number of blades</b>	7
<b>Balancing grade according to DIN ISO 1940-1</b>	G 6.3
<b>Direction of rotation</b>	Clockwise, viewed toward rotor
<b>Degree of protection</b>	IP24; Electronics IP 54
<b>Insulation class</b>	"B"
<b>Moisture (F) / Environmental (H) protection class</b>	H2+
<b>Max. permitted ambient temp. for motor (transport/storage)</b>	+ 80 °C
<b>Min. permitted ambient temp. for motor (transport/storage)</b>	- 40 °C
<b>Installation position</b>	Shaft horizontal or rotor on bottom; rotor on top on request
<b>Condensation drainage holes</b>	None
<b>Cooling hole/opening</b>	On rotor side
<b>Mode</b>	S1
<b>Motor bearing</b>	Ball bearing
<b>Technical features</b>	<ul style="list-style-type: none"> <li>- Tach output</li> <li>- Cable break detection with control line</li> <li>- Motor current limitation</li> <li>- Soft start</li> <li>- PWM control input</li> </ul>
<b>Electrical hookup</b>	With plug
<b>Motor protection</b>	Reverse polarity and locked-rotor protection
<b>With cable</b>	Variable
<b>Approval</b>	UL 507; VDE

## Product drawing

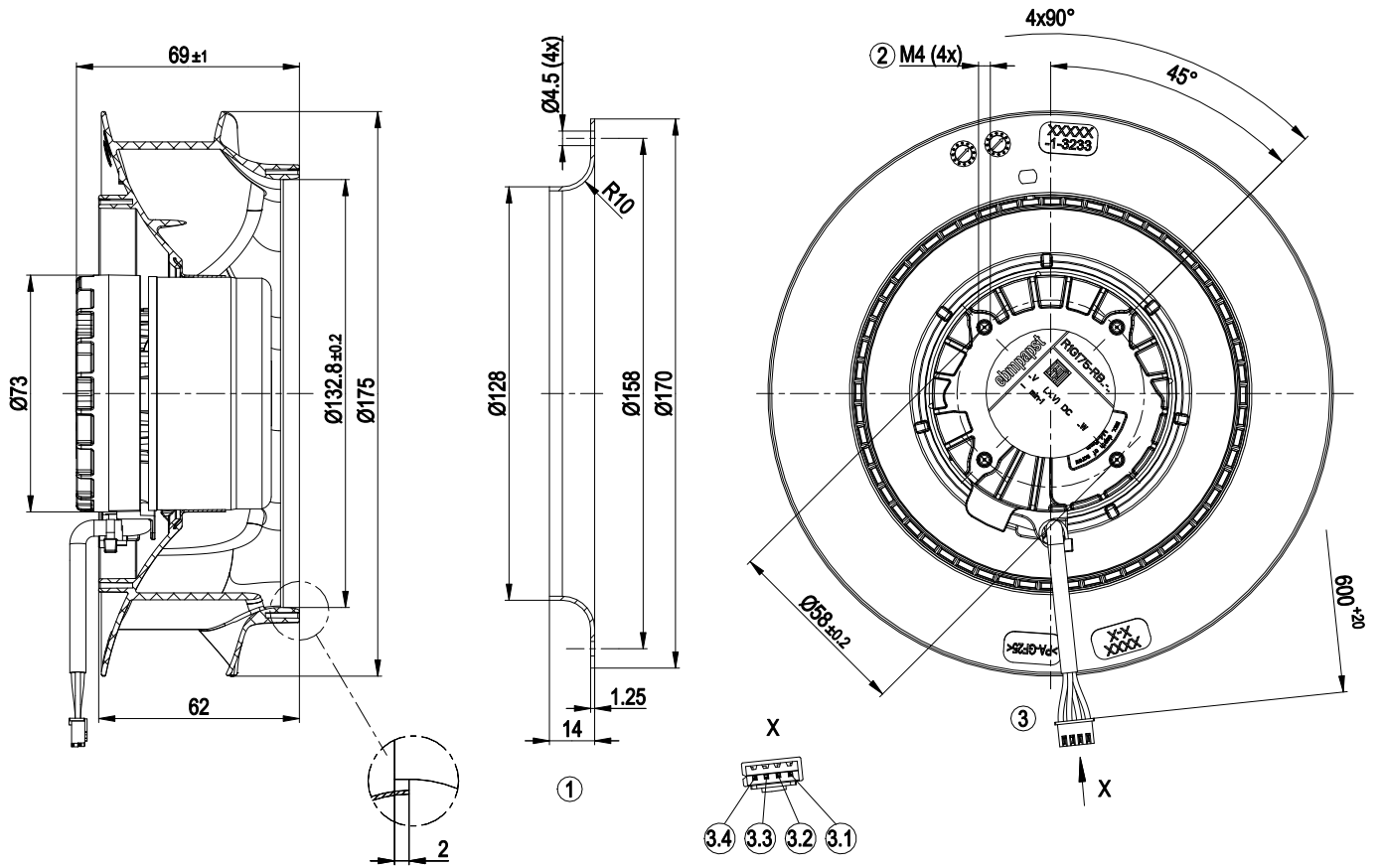

1	Accessory part: inlet ring 09576-2-4013 not included in scope of delivery
2	Max. clearance for screw 6 mm
3	Cable PVC AWG20, 4-pole connector housing JST XHP-04, 4x crimped socket JST SXH-001T-P0.6
3.1	UN +48 VDC (red)
3.2	PWM (black)
3.3	Tach (white)
3.4	GND (blue)

# EC centrifugal fan

backward-curved, single-intake

## Connection diagram

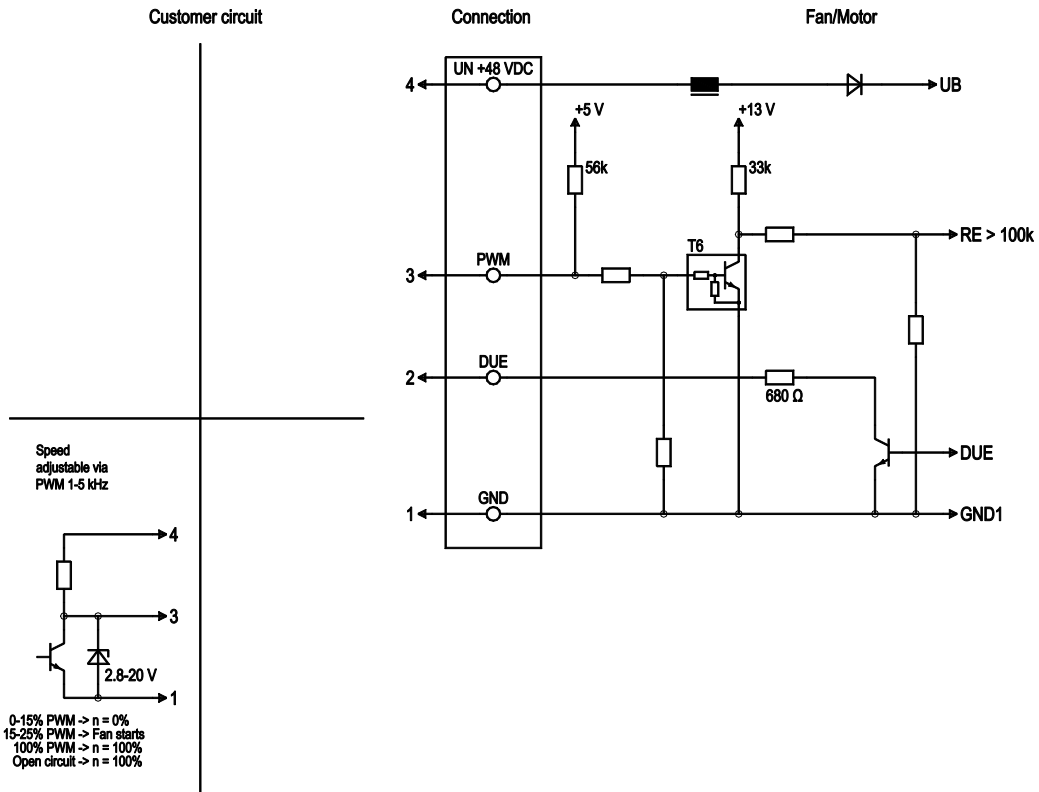

No.	Conn.	Designation	Color	Function/assignment
	1	GND	blue	Reference ground
	2	DUE	white	Tach output, 2 pulses per revolution, Isink max = 10 mA
	3	PWM	black	Control input PWM, 1-5 kHz, 2.8-20 V
	4	UN +48 VDC	red	Power supply 48 VDC, see nameplate for voltage range, maximum ripple 3.5%



## Curves: Air performance

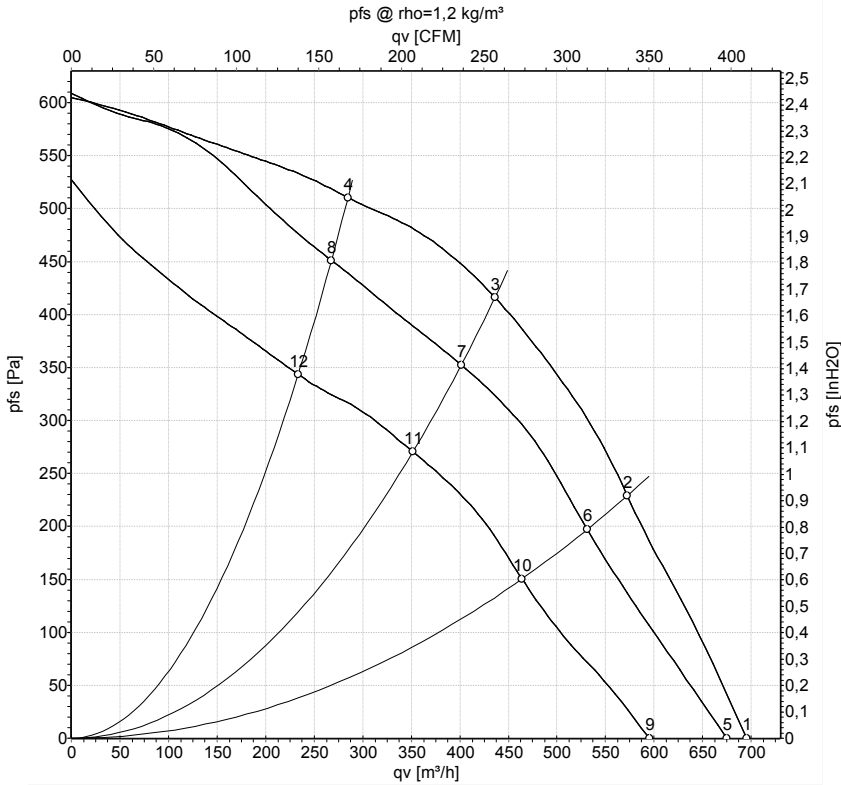

Measurement: LU-162002-1  
 Measurement: LU-161951-1  
 Measurement: LU-161999-1

Air performance measured according to ISO 5801 installation category A. For detailed information on the measurement setup, contact ebmpapst. Intake sound level: Sound power level according to ISO 13347 / sound pressure level measured at 1 m distance from fan axis. The values given are valid under the specified measuring conditions and may vary due to conditions of installation. For deviations from the standard configuration, the parameters have to be checked on the installed unit.

## Measured values

	U	n	P <sub>ed</sub>	I	q <sub>v</sub>	p <sub>fs</sub>	q <sub>v</sub>	p <sub>fs</sub>
	V	min <sup>-1</sup>	W	A	m <sup>3</sup> /h	Pa	cfm	inH <sub>2</sub> O
1	60	4005	83	2.00	695	0	410	0.00
2	60	4010	98	2.28	570	229	335	0.92
3	60	4005	104	2.38	435	417	255	1.67
4	60	4010	96	2.24	285	510	170	2.05
5	48	3950	75	1.85	675	0	395	0.00
6	48	3735	78	2.00	530	200	315	0.80
7	48	3700	79	2.03	400	350	235	1.41
8	48	3765	78	1.98	270	450	160	1.81
9	36	3425	49	1.52	595	0	350	0.00
10	36	3265	52	1.63	465	150	275	0.60
11	36	3240	53	1.65	350	270	205	1.08
12	36	3300	52	1.61	235	343	140	1.38

U = Power supply · n = Speed (rpm) · P<sub>ed</sub> = Power consumption · I = Current draw · q<sub>v</sub> = Air flow · p<sub>fs</sub> = Pressure increase

