

R1G225-RA15-10

EC centrifugal fan - RadiCal®

backward curved, single inlet

ASIA PACIFIC SHENGRUI LIMITED

Phone +00852 56261528

info@apacfan.com

www.apacfan.com

Nominal data

Type	R1G225-RA15-10	
Motor	M1G074-CF	
Nominal voltage	VDC	48
Nominal voltage range	VDC	36 .. 60
Type of data definition		fa
Speed	min ⁻¹	2700
Power input	W	115
Current draw	A	2.7
Min. ambient temperature	°C	-25
Max. ambient temperature	°C	+70
Starting current	A	4

ml = max. load · me = max. efficiency · fa = running at free air · cs = customer specs · cu = customer unit
Subject to alterations



Technical features

Mass	2 kg
Size	225 mm
Surface of rotor	Coated in black
Material of impeller	PA plastic
Number of blades	7
Direction of rotation	Clockwise, seen on rotor
Type of protection	IP 44; Depending on installation and position
Insulation class	"B"
Humidity class	F4-2
Max. permissible ambient motor temp. (transp./ storage)	+80 °C
Min. permissible ambient motor temp. (transp./storage)	-40 °C
Mounting position	Any
Condensate discharge holes	None
Operation mode	S1
Motor bearing	Ball bearing
Technical features	<ul style="list-style-type: none"> - Tach output - Motor current limit - Soft start - PWM control input
Motor protection	Reverse polarity and locked-rotor protection
Cable exit	Variable
Product conforming to standard	EN 60950-1
Approval	UL 507; CCC; VDE; CSA C22.2 Nr.113

Product drawing

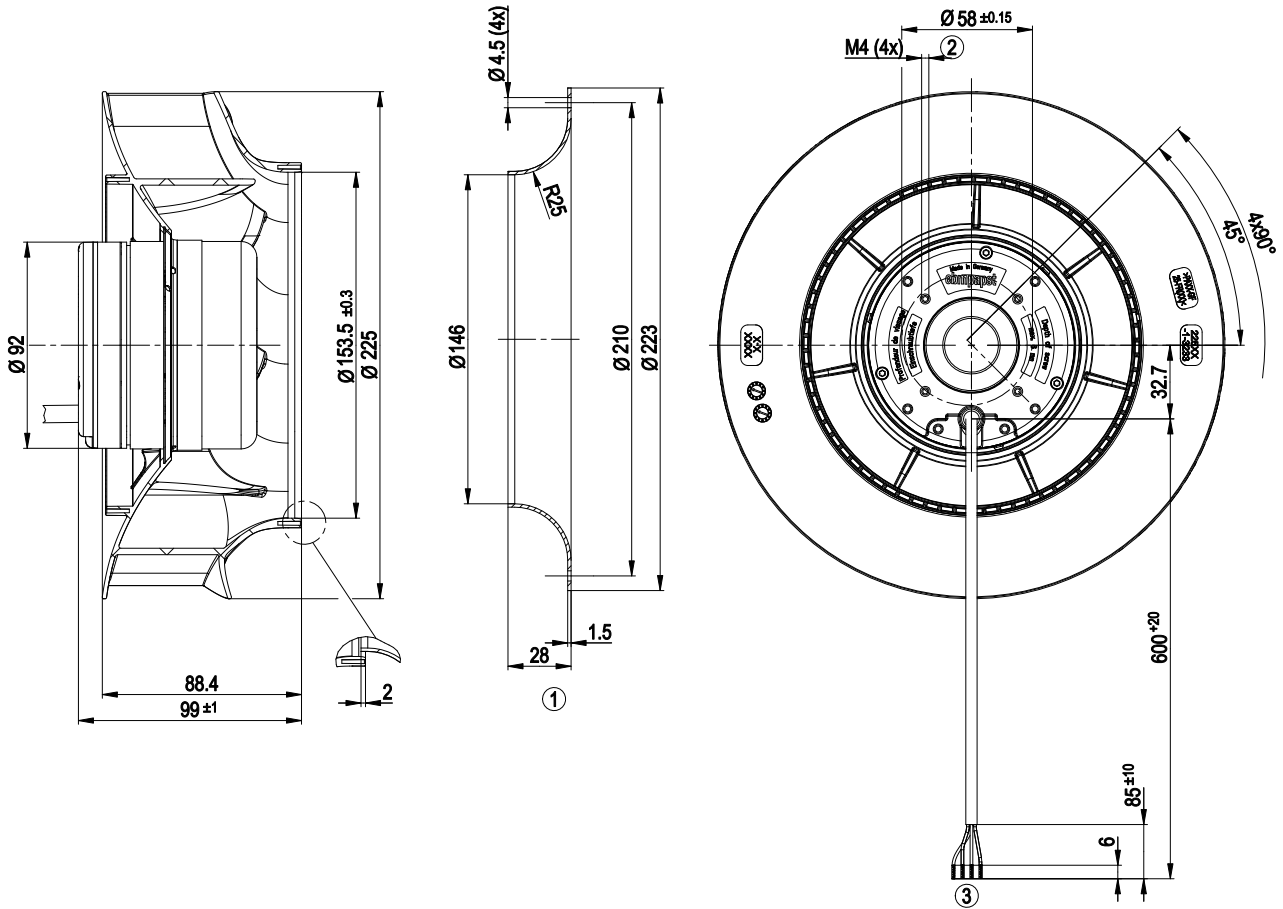

1	Accessory part: Inlet nozzle 96358-2-4013, not included in the standard scope of delivery
2	Depth of screw max. 6 mm
3	Connection line PVC AWG18, 4 x brass lead tips crimped

Connection screen

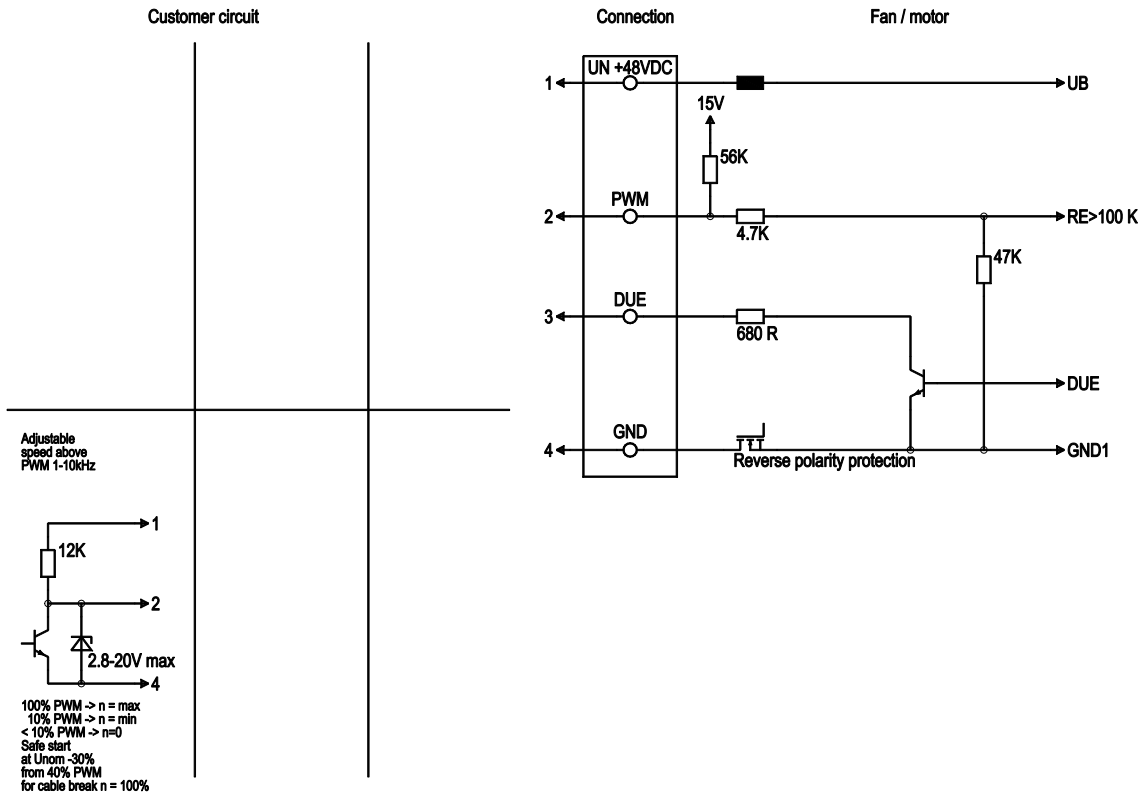

Line	No.	Signal	Colour	Function / assignment
1	1	Un +48 VDC	red	Power supply 48 VDC, residual ripple 3.5 %
1	2	PWM	yellow	PWM level 2.8V-20V / cable break detection
1	3	Tach	white	Speed monitoring output, open Col. 2 pulses per revolution, Isink max = 10 mA
1	4	GND	blue	Reference mass

Charts: Air flow

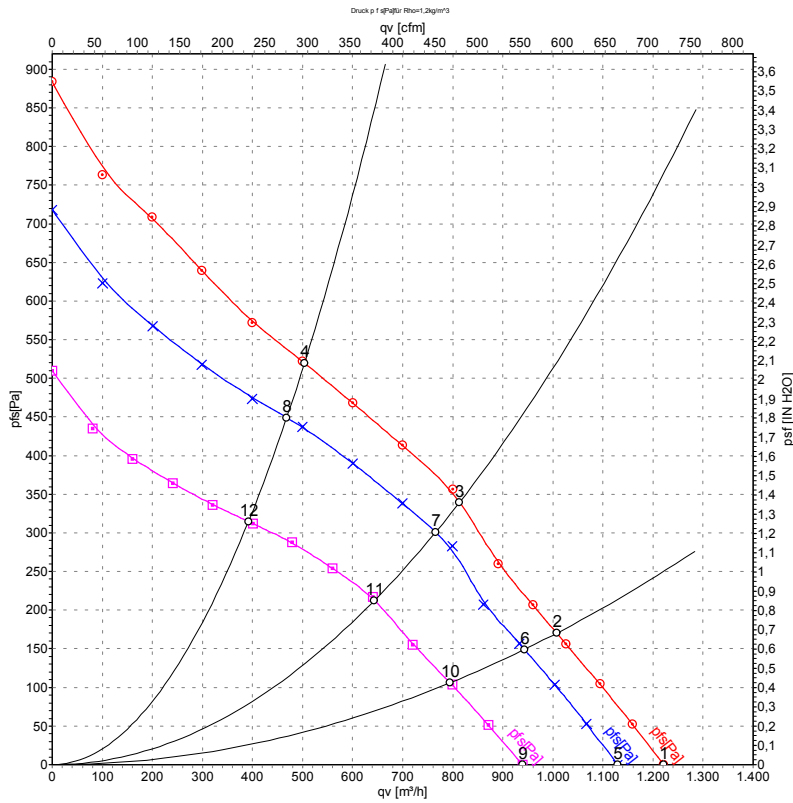

Measurement: LU-132584
 Measurement: LU-132581
 Measurement: LU-132583

Air performance measured as per ISO 5801 Installation category A. For detailed information on the measuring set-up, please contact ebm-papst. Suction-side noise levels: L_{WA} measured as per ISO 13347 / L_{pA} measured with 1m distance to fan axis. The values given are valid under the measuring conditions mentioned above and may vary according to the actual installation situation. With any deviation from the standard set-up, the specific values have to be checked and reviewed with the unit installed.

Measured values

	U	n	P _{ed}	I	qv	p _{fs}
	V	min ⁻¹	W	A	m ³ /h	Pa
1	57	2980	150	3.05	1220	0
2	57	2840	153	3.16	1010	170
3	57	2855	152	3.14	815	343
4	57	2955	150	3.06	505	520
5	48	2700	115	2.70	1130	0
6	48	2670	123	2.90	945	150
7	48	2685	123	2.89	765	300
8	48	2750	120	2.81	470	450
9	36	2310	70	2.19	940	0
10	36	2245	75	2.34	795	106
11	36	2260	74	2.30	645	215
12	36	2300	71	2.21	390	315

U = Supply voltage · n = Speed · P_{ed} = Power input · I = Current draw · qv = Air flow · p_{fs} = Pressure increase

