

## ASIA PACIFIC SHENGRUI LIMITED

Phone +00852 56261528

info@apacfan.com

www.apacfan.com

## Nominal data

Type	K3G630-FB32-03	
Motor	M3G150-IF	
Phase		3~
Nominal voltage	VAC	400
Nominal voltage range	VAC	380 .. 480
Frequency	Hz	50/60
Method of obtaining data		ml
Status		prelim.
Speed (rpm)	min <sup>-1</sup>	1420
Power consumption	W	3700
Current draw	A	5.7
Min. ambient temperature	°C	-40
Max. ambient temperature	°C	45

ml = Max. load · me = Max. efficiency · fa = Free air · cs = Customer specification · ce = Customer equipment  
Subject to change

Occasional start-up at temperatures between -40 °C and -25 °C is permitted. For continuous operation at ambient temperatures below -25 °C (such as refrigeration applications), a fan design with special low-temperature bearings must be used.

## Data according to Commission Regulation (EU) 327/2011

		Actual	Req. 2015			
01 Overall efficiency $\eta_{es}$	%	71.4	57.4	09 Power consumption $P_{ed}$	kW	3.66
02 Measurement category		A		09 Air flow $q_v$	m <sup>3</sup> /h	12685
03 Efficiency category		Static		09 Pressure increase $p_{fs}$	Pa	711
04 Efficiency grade N		76	62	10 Speed (rpm) n	min <sup>-1</sup>	1420
05 Variable speed drive		Yes		11 Specific ratio <sup>*</sup>		1.01

Data obtained at optimum efficiency level.

<sup>\*</sup> Specific ratio =  $1 + p_{fs} / 100\,000\text{ Pa}$

LU-194121

The efficiency values displayed for achieving conformity with the Ecodesign Regulation EU 327/2011 has been reached with defined air duct components (e.g. inlet rings). The dimensions must be requested from ebm-papst. If other air conduction geometries are used on the installation side, the ebm-papst evaluation loses its validity/the conformity must be confirmed again. The product does not fall within the scope of Regulation (EU) 2019/1781 due to the exception specified in Article 2 (2a) (motors completely integrated into a product).

## Technical description

<b>Weight</b>	51.4 kg
<b>Size</b>	630 mm
<b>Motor size</b>	150
<b>Rotor surface</b>	Painted black
<b>Electronics housing material</b>	Die-cast aluminum
<b>Impeller material</b>	PP plastic
<b>Support plate material</b>	Sheet steel, galvanized
<b>Support bracket material</b>	Steel, painted black
<b>Inlet nozzle material</b>	Sheet steel, galvanized
<b>Number of blades</b>	6
<b>Direction of rotation</b>	Clockwise, viewed toward rotor
<b>Degree of protection</b>	IP55
<b>Insulation class</b>	"F"
<b>Moisture (F) / Environmental (H) protection class</b>	H1
<b>Ambient temperature note</b>	Occasional start-up at temperatures between -40°C and -25°C is permitted. For continuous operation at ambient temperatures below -25°C (such as refrigeration applications), use must be made of a fan design with special low-temperature bearings.
<b>Max. permitted ambient temp. for motor (transport/storage)</b>	+80 °C
<b>Min. permitted ambient temp. for motor (transport/storage)</b>	-40 °C
<b>Installation position</b>	See legend on product drawing
<b>Condensation drainage holes</b>	On rotor side
<b>Mode</b>	S1
<b>Motor bearing</b>	Ball bearing
<b>Technical features</b>	<ul style="list-style-type: none"> <li>- Operation and alarm display with LED</li> <li>- External 15-50 VDC input (parameterization)</li> <li>- Alarm relay</li> <li>- Integrated PI controller</li> <li>- Configurable inputs/outputs (I/O)</li> <li>- MODBUS V6.3</li> <li>- Motor current limitation</li> <li>- RS-485 MODBUS-RTU</li> <li>- Soft start</li> <li>- Voltage output 3.3-24 VDC, Pmax = 800 mW</li> <li>- Control interface with SELV potential safely disconnected from the mains</li> <li>- Thermal overload protection for electronics/motor</li> <li>- Line undervoltage / phase failure detection</li> </ul>
<b>EMC immunity to interference</b>	According to EN 61000-6-2 (industrial environment)
<b>EMC interference emission</b>	According to EN 61000-6-3 (household environment), except EN 61000-3-2 for professionally used equipment with a total rated power greater than 1 kW
<b>Touch current according to IEC 60990 (measuring circuit Fig. 4, TN system)</b>	<= 3.5 mA
<b>Electrical hookup</b>	Terminal box

# EC centrifugal module - RadiCal

backward-curved, single-intake

with support bracket

<b>Protection class assignment</b>	I; If a protective earth is connected by the customer This component for installation may have several local protection classes. This information relates to this component's basic design. The final protection class is based on the component's intended installation and connection.
<b>Conformity with standards</b>	EN 61800-5-1; CE
<b>Approval</b>	CSA C22.2 No. 77 + CAN/CSA-E60730-1; EAC; UL 1004-7 + 60730-1



# EC centrifugal module - RadiCal

backward-curved, single-intake

with support bracket

## Product drawing

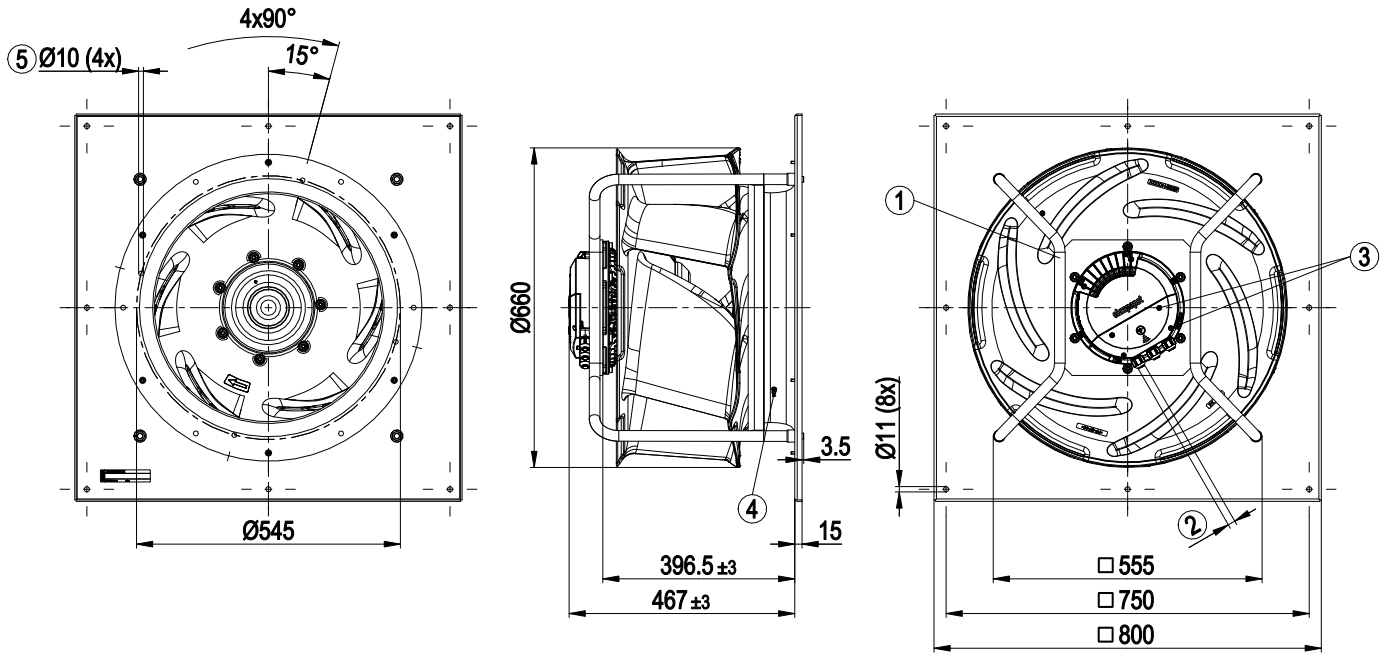

1	Installed position: shaft horizontal (install support struts only vertically as illustrated) or rotor on bottom
2	Cable diameter min. 4 mm, max. 10 mm, tightening torque $4 \pm 0.6$ Nm (The tightening torque is designed for PVC cables. If the cable materials are different, the tightening torque may have to be adjusted)
3	Tightening torque $1.5 \pm 0.2$ Nm
4	Inlet ring with pressure tap (k-factor: 535)
5	Attachment holes for FlowGrid 00630-2-2957 (not included in scope of delivery)

# EC centrifugal module - RadiCal

backward-curved, single-intake  
with support bracket

## Connection diagram

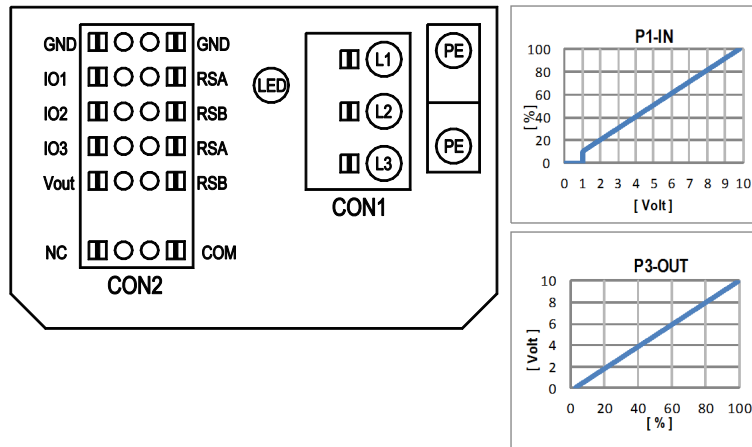

No.	Conn.	Designation	Function/assignment
	CON1	L1, L2, L3	Power supply, phase, see nameplate for voltage range
	PE	PE	Protective earth
	CON2	RSA	RS485 interface for MODBUS, RSA; SELV
	CON2	RSB	RS485 interface for MODBUS, RSB; SELV
	CON2	GND	Reference ground for control interface, SELV
	CON2	IO1	Function parameterizable (see "Optional interface functions" table) Factory setting: Digital input - high active, function: Disable input, SELV - inactive: Pin open or applied voltage < 1.5 VDC - active: applied voltage 3.5-50 VDC Reset function: Triggering of error reset on change of state from "enabled" to "disabled"
	CON2	IO2	Function parameterizable (see "Optional interface functions" table) Factory setting: Analog input 0-10 V / PWM, Ri=100 kΩ, function: Set value Characteristic curve parameterizable (see input characteristic curve P1-IN), SELV
	CON2	IO3	Function parameterizable (see "Optional interface functions" table) Factory setting: Analog output 0-10 V, max. 5 mA, function: Fan modulation level Characteristic curve parameterizable (see output characteristic curve P3-OUT), SELV
	CON2	Vout	Voltage output 3.3-24 VDC ±5%, Pmax=800 mW, voltage parameterizable Factory setting: 10 VDC short-circuit-proof, supply for external devices, SELV alternatively: 15-50 VDC input for parameterization via MODBUS without line voltage
	CON2	COM	Status relay, floating status contact, common connection, contact rating 250 VAC / 2 A (AC1) / min. 10 mA, reinforced insulation on supply side and on control interface side
	CON2	NC	Status relay, floating status contact, break for failure
		LED	green: status = good, ready for operation orange: status = warning red: status = failure
		P1-IN	Input characteristic curve
		P3-OUT	Output characteristic curve

## Terminal/plug assignment

CON2	configurable IO mode	electrical specification	configurable IO functions: normal / inverse	MODBUS Register for IO mode configuration	D101 [..]	D147 [..]	D104 [..]	D12E [..]	D148 [..]	D16C [..]	D16A [..]	(selected directly via IO mode)	(selected directly via IO mode)	D130 [0]	D130 [1]	D130 [2]	D130 [5]	D00C [1]	D130 [4]	
IO1	<ul style="list-style-type: none"> <li>configurable option</li> </ul>	not active: pin open or applied voltage < 1,5VDC RI = 100k, characteristic curve parameterizable, $f_{PWM} = 1k..10kHz$ , SELV	configurable IO functions: normal / inverse	D158 [0]																
IO2		not active: pin open or applied voltage < 1,5VDC																		
IO3	<ul style="list-style-type: none"> <li>configurable option</li> </ul>	not active: pin open or applied voltage < 1,5VDC not active: pin open or applied voltage 3,5-50VDC PWM = 40Hz - 10kHz, characteristics parameterizable active: pin open or applied voltage 3,5-50VDC																		
		40Hz - 10kHz, characteristics parameterizable active: applied voltage 3,5-50VDC not active: pin open or applied voltage < 1,5VDC, SELV		D15A [8]																
RSA	RS485 bus connection,	MODBUS RTU, specification V6.3, SELV																		
Yout	alternatively: Input auxiliary power supply for parameterization via RS485/MODBUS RTU without line voltage	supply for external devices, SELV		D16E [..]																



## Curves: Air performance 50 Hz

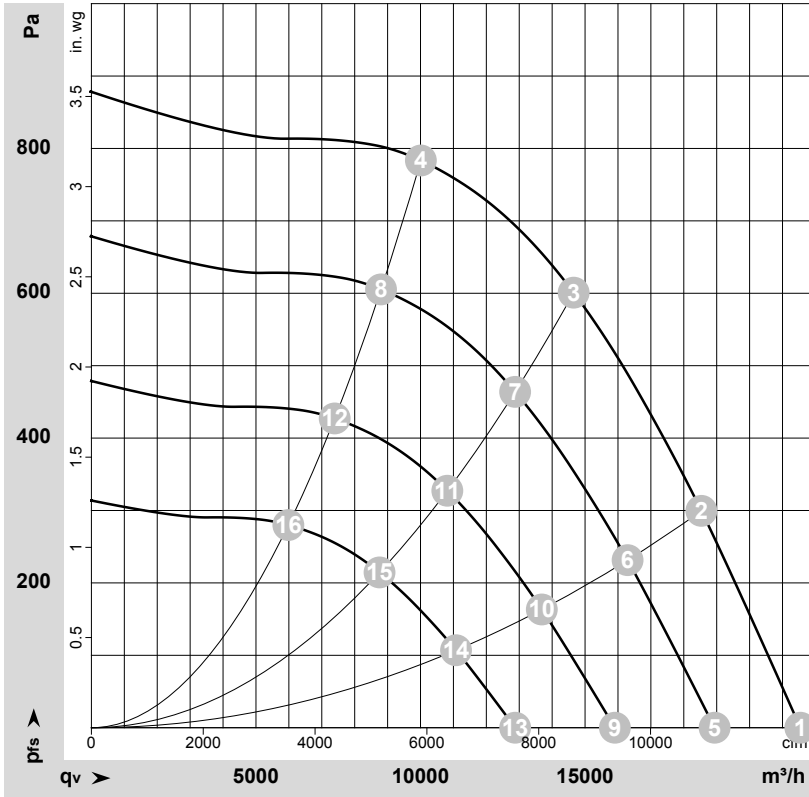

$\rho = 1.15 \text{ kg/m}^3 \pm 2 \%$

Measurement: LU-194121-1

Air performance measured according to ISO 5801 installation category A. For detailed information on the measurement setup, contact ebm-papst. Intake sound level: Sound power level according to ISO 13347 / sound pressure level measured at 1 m distance from fan axis. The values given are valid under the specified measuring conditions and may vary due to conditions of installation. For deviations from the standard configuration, the parameters have to be checked on the installed unit.

## Measured values

	Wired	U	f	n	P <sub>ed</sub>	I	LpA <sub>in</sub>	LwA <sub>in</sub>	LwA <sub>out</sub>	q <sub>v</sub>	p <sub>fs</sub>	q <sub>v</sub>	p <sub>fs</sub>
		V	Hz	min <sup>-1</sup>	W	A	dB(A)	dB(A)	dB(A)	m <sup>3</sup> /h	Pa	cfm	in. wg
1	3~	400	50	1420	2234	3.47	81	89	92	21540	0	12680	0.00
2	3~	400	50	1420	3118	4.78	80	86	89	18535	300	10910	1.20
3	3~	400	50	1420	3700	5.70	73	81	85	14655	600	8625	2.41
4	3~	400	50	1420	3520	5.38	73	81	85	10010	780	5890	3.13
5	3~	400	50	1250	1517	2.36	78	86	89	18935	0	11145	0.00
6	3~	400	50	1250	2118	3.25	77	83	85	16295	232	9590	0.93
7	3~	400	50	1250	2514	3.84	70	78	82	12875	465	7580	1.87
8	3~	400	50	1250	2391	3.65	70	78	82	8800	609	5180	2.44
9	3~	400	50	1050	899	1.40	74	82	84	15905	0	9365	0.00
10	3~	400	50	1050	1255	1.92	73	78	81	13685	164	8055	0.66
11	3~	400	50	1050	1490	2.27	65	73	77	10815	328	6365	1.32
12	3~	400	50	1050	1417	2.16	65	73	77	7390	430	4350	1.73
13	3~	400	50	850	477	0.74	68	76	79	12875	0	7580	0.00
14	3~	400	50	850	666	1.02	67	73	76	11080	107	6520	0.43
15	3~	400	50	850	791	1.21	60	68	72	8755	215	5155	0.86
16	3~	400	50	850	752	1.15	60	68	72	5985	282	3520	1.13

Wired = Wiring · U = Voltage · f = Frequency · n = Speed (rpm) · P<sub>ed</sub> = Power consumption · I = Current draw · LpA<sub>in</sub> = Sound pressure level intake side · LwA<sub>in</sub> = Sound power level intake side  
 LwA<sub>out</sub> = Sound power level outlet side · q<sub>v</sub> = Air flow · p<sub>fs</sub> = Pressure increase

