

ASIA PACIFIC SHENGRUI LIMITED

Phone +00852 56261528

info@apacfan.com

www.apacfan.com

Nominal data

| | | |
|--------------------------|-------------------|------------|
| Type | K3G400-HB41-01 | |
| Motor | M3G150-IF | |
| Phase | | 3~ |
| Nominal voltage | VAC | 400 |
| Nominal voltage range | VAC | 380 .. 480 |
| Frequency | Hz | 50/60 |
| Method of obtaining data | | ml |
| Speed (rpm) | min ⁻¹ | 3700 |
| Power consumption | W | 6000 |
| Current draw | A | 9.1 |
| Min. ambient temperature | °C | -40 |
| Max. ambient temperature | °C | 40 |

ml = Max. load · me = Max. efficiency · fa = Free air · cs = Customer specification · ce = Customer equipment
Subject to change

Data according to Commission Regulation (EU) 327/2011 (prEN 17166)

| | | Actual | Req. 2015 | | | |
|-----------------------------------|---|--------|-----------|--------------------------------|-------------------|------|
| 01 Overall efficiency η_{es} | % | 62 | 59.6 | 09 Power consumption P_{ed} | kW | 5.9 |
| 02 Measurement category | | A | | 09 Air flow q_v | m ³ /h | 6810 |
| 03 Efficiency category | | Static | | 09 Pressure increase p_{fs} | Pa | 1881 |
| 04 Efficiency grade N | | 64.4 | 62 | 10 Speed (rpm) n | min ⁻¹ | 3710 |
| 05 Variable speed drive | | Yes | | 11 Specific ratio [*] | | 1.02 |

Data obtained at optimum efficiency level.

^{*} Specific ratio = $1 + p_g / 100\,000\text{ Pa}$

LU-193984

The efficiency values displayed for achieving conformity with the Ecodesign Regulation EU 327/2011 has been reached with defined air duct components (e.g. inlet rings). The dimensions must be requested from ebmpapst. If other air conduction geometries are used on the installation side, the ebmpapst evaluation loses its validity/the conformity must be confirmed again. The product does not fall within the scope of Regulation (EU) 2019/1781 due to the exception specified in Article 2 (2a) (motors completely integrated into a product).

Technical description

| | |
|---|---|
| Weight | 41.6 kg |
| Size | 400 mm |
| Motor size | 150 |
| Rotor surface | Painted black |
| Electronics housing material | Die-cast aluminum |
| Impeller material | Sheet aluminum |
| Support plate material | Sheet steel, galvanized |
| Support bracket material | Steel, painted black |
| Inlet nozzle material | Sheet steel, galvanized |
| Number of blades | 5 |
| Direction of rotation | Clockwise, viewed toward rotor |
| Degree of protection | IP55 |
| Insulation class | "F" |
| Moisture (F) / Environmental (H) protection class | H1 |
| Ambient temperature note | Occasional start-up at temperatures between -40°C and -25°C is permitted. For continuous operation at ambient temperatures below -25°C (such as refrigeration applications), use must be made of a fan design with special low-temperature bearings. |
| Max. permitted ambient temp. for motor (transport/storage) | +80 °C |
| Min. permitted ambient temp. for motor (transport/storage) | -40 °C |
| Installation position | See product drawing |
| Condensation drainage holes | On rotor side |
| Mode | S1 |
| Motor bearing | Ball bearing |
| Technical features | <ul style="list-style-type: none"> - Output 10 VDC, max. 10 mA - Output for slave 0-10 V - External 24 V input (parameter setting) - External release input - Alarm relay - Integrated PID controller - Power limiter - Motor current limitation - PFC, passive - RS-485 MODBUS-RTU - Soft start - Control input 0-10 VDC - Control interface with SELV potential safely disconnected from the mains - Thermal overload protection for electronics/motor - Line undervoltage / phase failure detection |
| EMC immunity to interference | According to EN 61000-6-2 (industrial environment) |
| EMC interference emission | According to EN 61000-6-4 (industrial environment) |
| Touch current according to IEC 60990 (measuring circuit Fig. 4, TN system) | <= 3.5 mA |
| Electrical hookup | Terminal box |
| Motor protection | Reverse polarity and locked-rotor protection |
| Protection class | I (with customer connection of protective earth) |

K3G400-HB41-01

EC centrifugal module - RadiPac

backward-curved, single-intake

with support bracket

| | |
|----------------------------------|---|
| Conformity with standards | EN 61800-5-1; CE; UKCA |
| Approval | CSA C22.2 No. 77 + CAN/CSA-E60730-1; EAC; UL 1004-7 + 60730-1 |



EC centrifugal module - RadiPac

backward-curved, single-intake
with support bracket

Product drawing

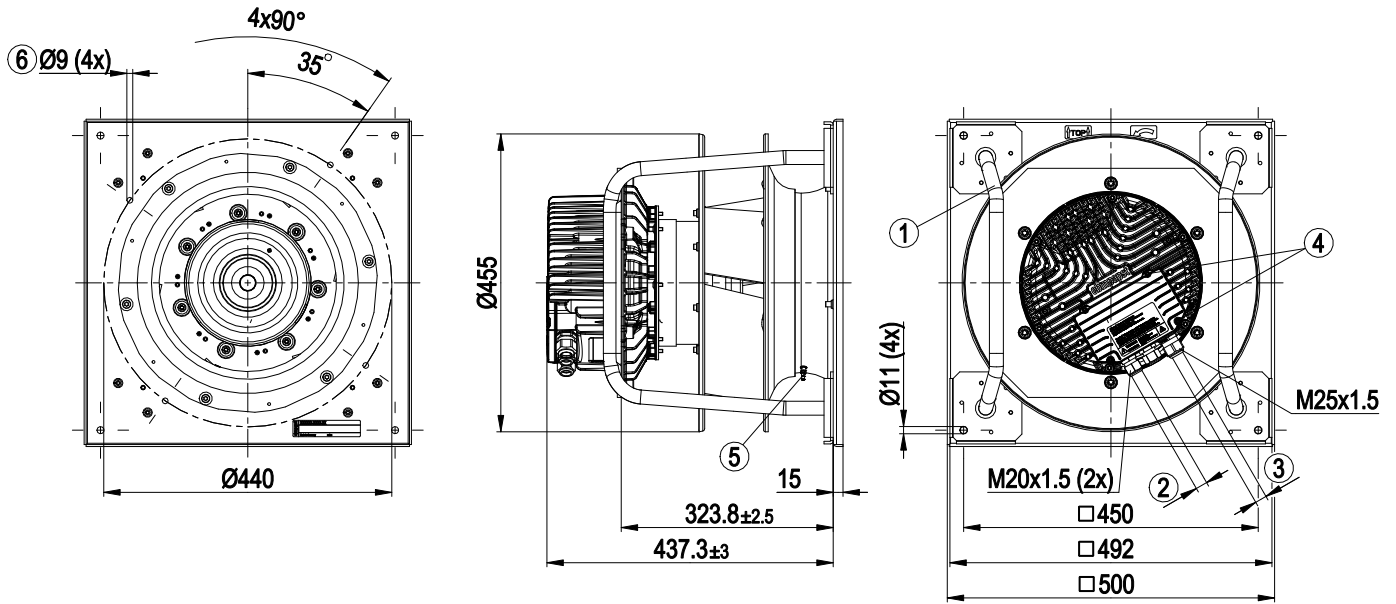

| | |
|---|--|
| 1 | Installed position: shaft horizontal (install support struts only vertically as illustrated) or rotor on bottom; rotor on top on request |
| 2 | Cable diameter min. 4 mm, max. 10 mm, tightening torque 4 ± 0.6 Nm |
| 3 | Cable diameter min. 9 mm, max. 16 mm, tightening torque 6 ± 0.9 Nm |
| 4 | Tightening torque 3.5 ± 0.5 Nm |
| 5 | Inlet ring with pressure tap (k-factor: 188) |
| 6 | Mounting holes for FlowGrid |

Connection diagram

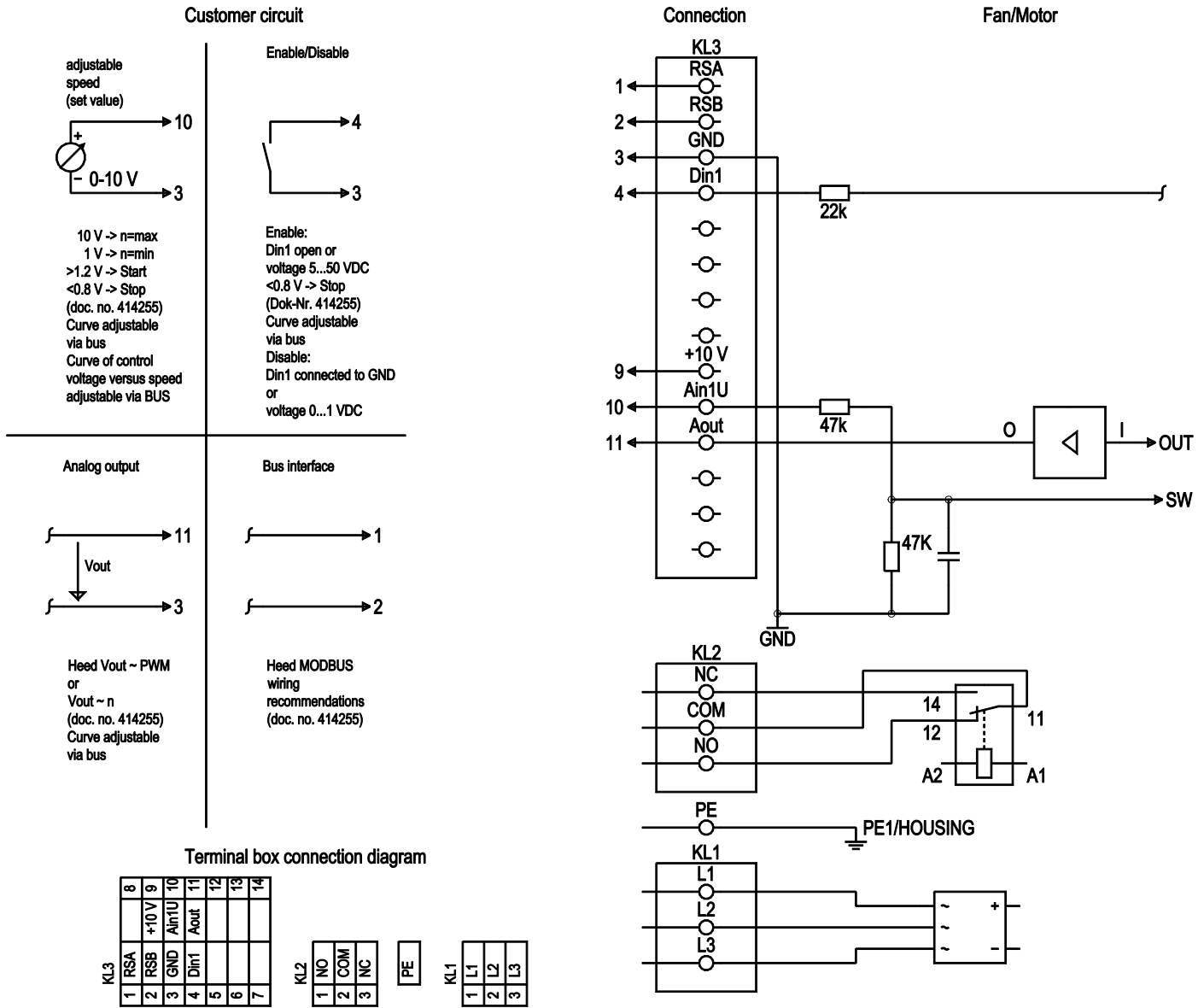

| No. | Conn. | Designation | Function/assignment |
|------|---------|-------------|--|
| KL 1 | 1, 2, 3 | L1, L2, L3 | Power supply, phase, see nameplate for voltage range |
| PE | PE | PE | Protective earth |
| KL2 | 1 | NO | Status relay, floating status contact, option 1: make for failure, option 2: make for error for run monitor |
| KL2 | 2 | COM | Status relay, floating status contact, common connection, contact rating 250 VAC / 2 A (AC1) / min. 10 mA; basic insulation on supply side and reinforced insulation on control interface side |
| KL2 | 3 | NC | Status relay, floating status contact, option 1: break for failure, option 2: break for error message for run monitor |
| KL 3 | 1 | RSA | RS485 interface for MODBUS, RSA; SELV |
| KL 3 | 2 | RSB | RS485 interface for MODBUS, RSB; SELV |
| KL 3 | 3 | GND | Reference ground for control interface; SELV |

EC centrifugal module - RadiPac

backward-curved, single-intake

with support bracket

| No. | Conn. | Designation | Function/assignment |
|------|-------|-------------------|--|
| KL 3 | 4 | Din1 | Digital input 1: enable electronics, enable: pin open or applied voltage 5-50 VDC disable: bridge to GND or applied voltage < 1 VDC reset function: triggers software reset after a level change to < 1 VDC; SELV |
| KL 3 | - | - | - |
| KL 3 | - | - | - |
| KL3 | - | - | - |
| KL3 | - | - | - |
| KL 3 | 9 | 10 V / max. 10 mA | Voltage output, power supply for external devices (e.g. potentiometers), SELV |
| KL 3 | 10 | Ain1 U | Analog input 1, set value: 0-10 V, Ri = 100 kΩ, adjustable curve; SELV |
| KL 3 | 11 | Aout | Analog output 0-10 VDC, max. 5 mA, output of current motor modulation level / motor speed adjustable curve; SELV |
| KL 3 | - | - | - |
| KL 3 | - | - | - |
| KL 3 | - | - | - |



Curves: Air performance 50 Hz

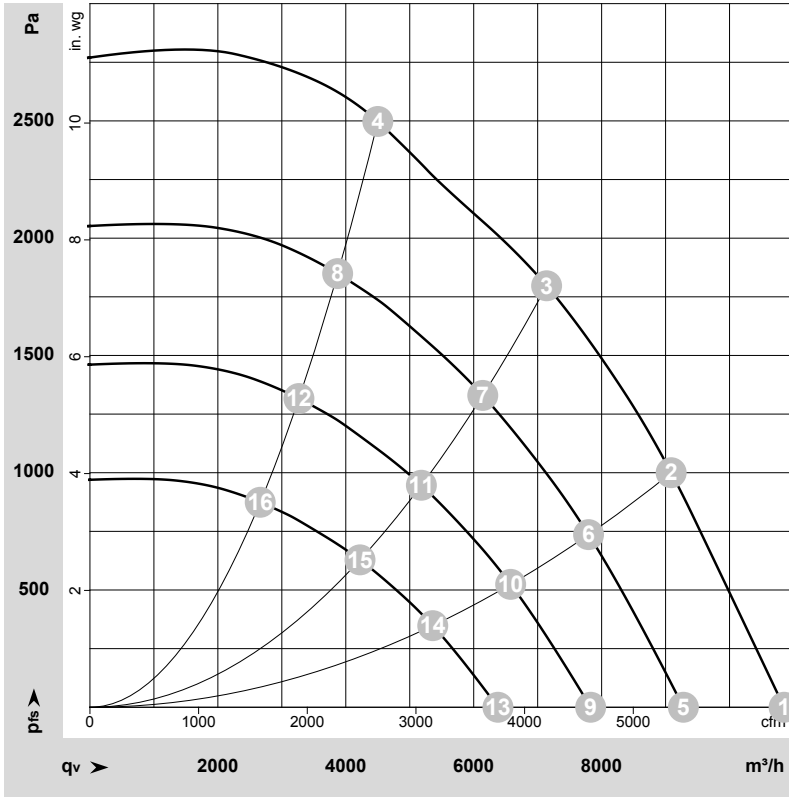

$\rho = 1.15 \text{ kg/m}^3 \pm 2 \%$

Measurement: LU-206043-1

Air performance measured according to ISO 5801 installation category A. For detailed information on the measurement setup, contact ebmpapst. Intake sound level: Sound power level according to ISO 13347 / sound pressure level measured at 1 m distance from fan axis. The values given are valid under the specified measuring conditions and may vary due to conditions of installation. For deviations from the standard configuration, the parameters have to be checked on the installed unit.

Measured values

| | Wired | U | f | n | P _{ed} | I | LpA _{in} | LwA _{in} | LwA _{out} | q _v | p _{fs} | q _v | p _{fs} |
|----|-------|-----|----|-------------------|-----------------|------|-------------------|-------------------|--------------------|-------------------|-----------------|----------------|-----------------|
| | | V | Hz | min ⁻¹ | W | A | dB(A) | dB(A) | dB(A) | m ³ /h | Pa | cfm | in. wg |
| 1 | 3~ | 400 | 50 | 3700 | 3562 | 5.52 | 94 | 102 | 107 | 10855 | 0 | 6390 | 0.00 |
| 2 | 3~ | 400 | 50 | 3700 | 5232 | 7.99 | 88 | 96 | 103 | 9085 | 1000 | 5350 | 4.01 |
| 3 | 3~ | 400 | 50 | 3700 | 6000 | 9.10 | 87 | 94 | 102 | 7140 | 1800 | 4200 | 7.23 |
| 4 | 3~ | 400 | 50 | 3700 | 6000 | 9.10 | 90 | 98 | 103 | 4500 | 2500 | 2650 | 10.04 |
| 5 | 3~ | 400 | 50 | 3200 | 2226 | 3.45 | 90 | 98 | 103 | 9280 | 0 | 5460 | 0.00 |
| 6 | 3~ | 400 | 50 | 3200 | 3300 | 5.04 | 84 | 92 | 99 | 7795 | 742 | 4590 | 2.98 |
| 7 | 3~ | 400 | 50 | 3200 | 3945 | 6.01 | 83 | 90 | 98 | 6140 | 1331 | 3615 | 5.34 |
| 8 | 3~ | 400 | 50 | 3200 | 3933 | 6.00 | 87 | 94 | 99 | 3875 | 1850 | 2280 | 7.43 |
| 9 | 3~ | 400 | 50 | 2700 | 1337 | 2.07 | 86 | 93 | 99 | 7830 | 0 | 4610 | 0.00 |
| 10 | 3~ | 400 | 50 | 2700 | 1982 | 3.03 | 80 | 88 | 95 | 6580 | 528 | 3870 | 2.12 |
| 11 | 3~ | 400 | 50 | 2700 | 2370 | 3.61 | 78 | 86 | 94 | 5180 | 948 | 3050 | 3.81 |
| 12 | 3~ | 400 | 50 | 2700 | 2362 | 3.60 | 82 | 90 | 95 | 3270 | 1317 | 1925 | 5.29 |
| 13 | 3~ | 400 | 50 | 2200 | 723 | 1.12 | 81 | 88 | 94 | 6380 | 0 | 3755 | 0.00 |
| 14 | 3~ | 400 | 50 | 2200 | 1072 | 1.64 | 75 | 83 | 90 | 5360 | 351 | 3155 | 1.41 |
| 15 | 3~ | 400 | 50 | 2200 | 1282 | 1.95 | 73 | 81 | 89 | 4220 | 629 | 2485 | 2.53 |
| 16 | 3~ | 400 | 50 | 2200 | 1278 | 1.95 | 77 | 85 | 90 | 2665 | 874 | 1565 | 3.51 |

Wired = Wiring · U = Voltage · f = Frequency · n = Speed (rpm) · P_{ed} = Power consumption · I = Current draw · LpA_{in} = Sound pressure level intake side · LwA_{in} = Sound power level intake side · LwA_{out} = Sound power level outlet side · q_v = Air flow · p_{fs} = Pressure increase

