

backward curved, single inlet

with support bracket

## ASIA PACIFIC SHENGRUI LIMITED

Phone +00852 56261528

info@apacfan.com

www.apacfan.com

## Nominal data

Type	K3G310-PH58-02	
Motor	M3G112-GA	
Phase		3~
Nominal voltage	VAC	400
Nominal voltage range	VAC	380 .. 480
Frequency	Hz	50/60
Type of data definition		ml
Speed (rpm)	min <sup>-1</sup>	4000
Power input	W	2950
Current draw	A	4.6
Min. ambient temperature	°C	-25
Max. ambient temperature	°C	40

ml = Max. load · me = Max. efficiency · fa = Running at free air · cs = Customer specs · cu = Customer unit  
Subject to alterations

## Data according to ErP directive

		Actual	Request 2015
01 Overall efficiency $\eta_{es}$	%	66.1	56.4
02 Measurement category		A	
03 Efficiency category		Static	
04 Efficiency grade N		71.7	62
05 Variable speed drive		Yes	

Data definition with optimum efficiency.

The ErP data is determined using a motor-impeller combination in a standardised measurement configuration.

09 Power input $P_{ed}$	kW	2.93
09 Air flow $q_v$	m <sup>3</sup> /h	4505
09 Pressure increase $p_{fs}$	Pa	1479
10 Speed (rpm) $n$	min <sup>-1</sup>	4045
11 Specific ratio*		1.02

\* Specific ratio =  $1 + p_{fs} / 100\,000\text{ Pa}$

LU-176710



### Technical features

<b>Mass</b>	18 kg
<b>Size</b>	310 mm
<b>Surface of rotor</b>	Coated in black
<b>Material of electronics housing</b>	Die-cast aluminium
<b>Material of impeller</b>	Aluminium sheet
<b>Material of mounting plate</b>	Sheet steel, galvanised
<b>Material of support bracket</b>	Steel, coated in black
<b>Material of inlet nozzle</b>	Sheet steel, galvanised
<b>Number of blades</b>	5
<b>Direction of rotation</b>	Clockwise, seen on rotor
<b>Type of protection</b>	IP 54
<b>Insulation class</b>	"B"
<b>Humidity (F)/environmental protection class (H)</b>	H1
<b>Max. permissible ambient motor temp. (transp./ storage)</b>	+80 °C
<b>Min. permissible ambient motor temp. (transp./storage)</b>	-40 °C
<b>Mounting position</b>	Refer to product drawing
<b>Condensate discharge holes</b>	Rotor-side
<b>Operation mode</b>	S1
<b>Motor bearing</b>	Ball bearing
<b>Technical features</b>	<ul style="list-style-type: none"> <li>- Output 10 VDC, max. 10 mA</li> <li>- Output 20 VDC, max. 50 mA</li> <li>- Output for slave 0-10 V</li> <li>- Operation and alarm display</li> <li>- Input for sensor 0-10 V or 4-20 mA</li> <li>- External 24 V input (programming)</li> <li>- External release input</li> <li>- Alarm relay</li> <li>- Integrated PID controller</li> <li>- Output limit</li> <li>- Motor current limit</li> <li>- PFC, passive</li> <li>- RS485 MODBUS RTU</li> <li>- Soft start</li> <li>- Control input 0-10 VDC / PWM</li> <li>- Control interface with SELV potential safely disconnected from the mains</li> <li>- Over-temperature protected electronics / motor</li> <li>- Line undervoltage / phase failure detection</li> </ul>
<b>Touch current acc. IEC 60990 (measuring network Fig. 4, TN system)</b>	<= 3.5 mA
<b>Electrical leads</b>	Via terminal box
<b>Motor protection</b>	Thermal overload protector (TOP) wired internally
<b>Protection class</b>	I (if protective earth is connected by customer)
<b>Product conforming to standard</b>	EN 61800-5-1; CE
<b>Approval</b>	C22.2 Nr.77 + CAN/CSA-E60730-1; UL 1004-7 + 60730; EAC

# EC centrifugal module - RadiPac

backward curved, single inlet  
with support bracket

## Product drawing

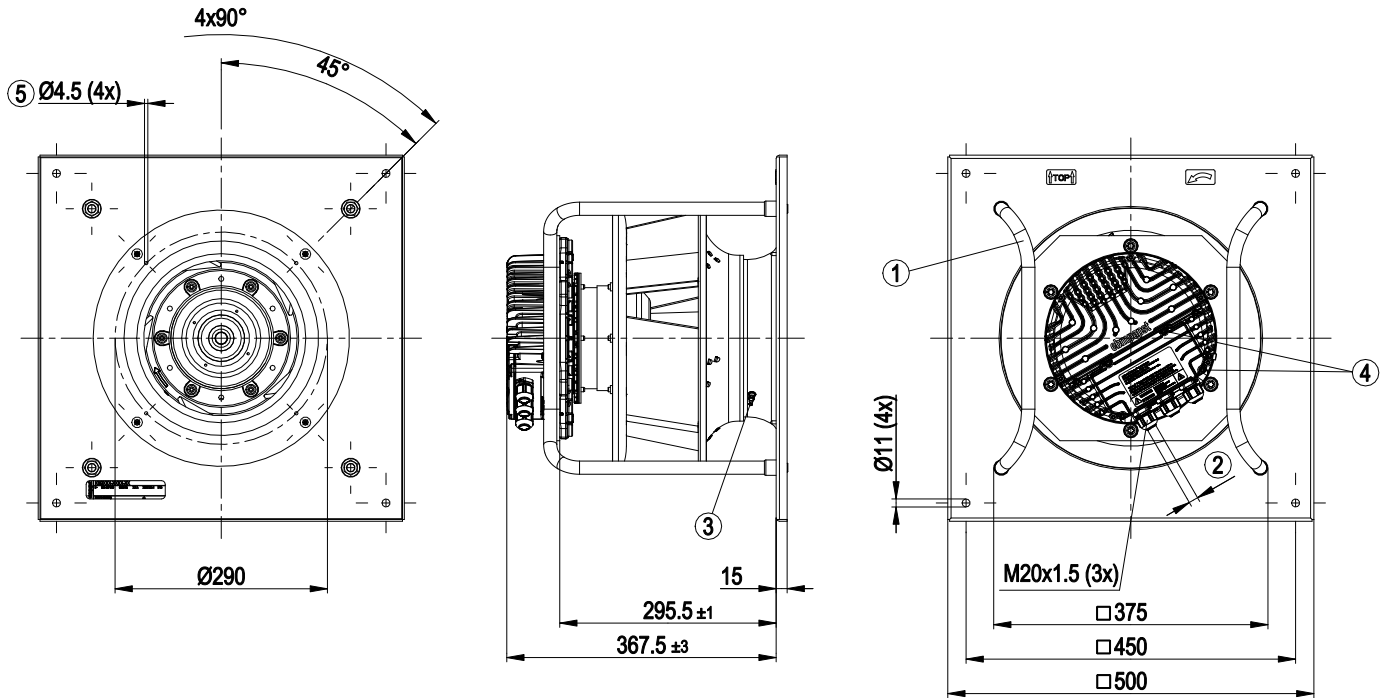

1	Installation position: Shaft horizontal (install the support struts only vertically as shown in the illustration!) or rotor on bottom; rotor on top on request
2	Cable diameter min. 4 mm, max. 10 mm, tightening torque 4±0.6 Nm
3	Inlet nozzle with pressure tap (k-factor: 116)
4	Tightening torque 3.5±0.5 Nm
5	Mounting holes for FlowGrid

# EC centrifugal module - RadiPac

backward curved, single inlet

with support bracket

## Connection screen

	8	Din 2
	9	Din 3
	10	GND
	11	Ain 2 U
	12	+ 20 V
	13	Ain 2 I
	14	Aout
1	RSA	
2	RSB	
3	GND	
4	Ain 1 U	
5	+ 10 V	
6	Ain 1 I	
7	Din 1	

KL 3

1	NO
2	COM
3	NC

KL 2

PE
----

PE

1	L1
2	L2
3	L3

KL 1

No.	Conn.	Designation	Function / assignment
KL 1	1	L1	Mains supply connection, supply voltage 3~380-480 VAC; 50/60 Hz
KL 1	2	L2	Mains supply connection, supply voltage 3~380-480 VAC; 50/60 Hz
KL 1	3	L3	Mains supply connection, supply voltage 3~380-480 VAC; 50/60 Hz
PE		PE	Earth connection, PE connection
KL 2	1	NO	Status relay, floating status contact; normally open; close with error
KL2	2	COM	Status relay; floating status contact; changeover contact; common connection; contact rating 250 VAC / max. 2 A (AC1) / min. 10 mA
KL2	3	NC	Status relay, floating status contact; break with error
KL 3	1	RSA	Bus connection RS-485, RSA, MODBUS RTU; SELV
KL 3	2	RSB	Bus connection RS-485, RSB, MODBUS RTU; SELV
KL 3	3 / 10	GND	Signal ground for control interface; SELV
KL 3	4	Ain1 U	Analogue input 1, set value: 0-10 V, Ri = 100 kΩ, parametrisable curve, only usable as alternative to input Ain1; SELV
KL 3	5	+ 10 V	Fixed voltage output 10 VDC, +10 V ±3%, max. 10 mA, short-circuit-proof, power supply for external devices (e.g. potentiometer), SELV
KL 3	6	Ain1 I	Analogue input 1, set value: 4-20 mA; Ri = 100 Ω, parametrisable curve, only usable as alternative to input Ain1 U; SELV
KL 3	7	Din1	Digital input 1: enabling of electronics, enabling: open pin or applied voltage 5-50 VDC disabling: bridge to GND or applied voltage <1 VDC reset function: triggers software reset after a level change to <1 VDC; SELV
KL 3	8	Din2	Digital input 2: parameter set switch 1/2, according to EEPROM setting, the valid/used parameter set can be selected via bus or via digital input DIN2. Parameter set 1: open pin or applied voltage 5-50 VDC Parameter set 2: bridge to GND or applied voltage <1 VDC; SELV
KL 3	9	Din3	Digital input 3: controller function of integrated controller, according to EEPROM setting, the controller function of the integrated controller is normally/inversely selectable per bus or per digital input normal: open pin or applied voltage 5-50 VDC inverse: bridge to GND or applied voltage <1 VDC; SELV
KL 3	11	Ain2 U	Analogue input 2, actual value: 0-10 V, Ri = 100 kΩ, parametrisable curve, only usable as alternative to input Ain2; SELV
KL 3	12	+ 20 V	Fixed voltage output 20 VDC, +20 V ±25/-10%, max. 50 mA, short-circuit-proof, power supply for external devices (e.g. sensors); SELV



# EC centrifugal module - RadiPac

backward curved, single inlet

with support bracket

No.	Conn.	Designation	Function / assignment
KL 3	13	Ain2 I	Analogue input 2, actual value: 4-20 mA, Ri = 100 $\Omega$ , parametrisable curve, only usable as alternative to input Ain2 U; SELV
KL 3	14	Aout	Analogue output 0-10 VDC, max. 5 mA, output of the current motor level control coefficient / motor speed parametrisable curve; SELV



## Charts: Air flow 50 Hz

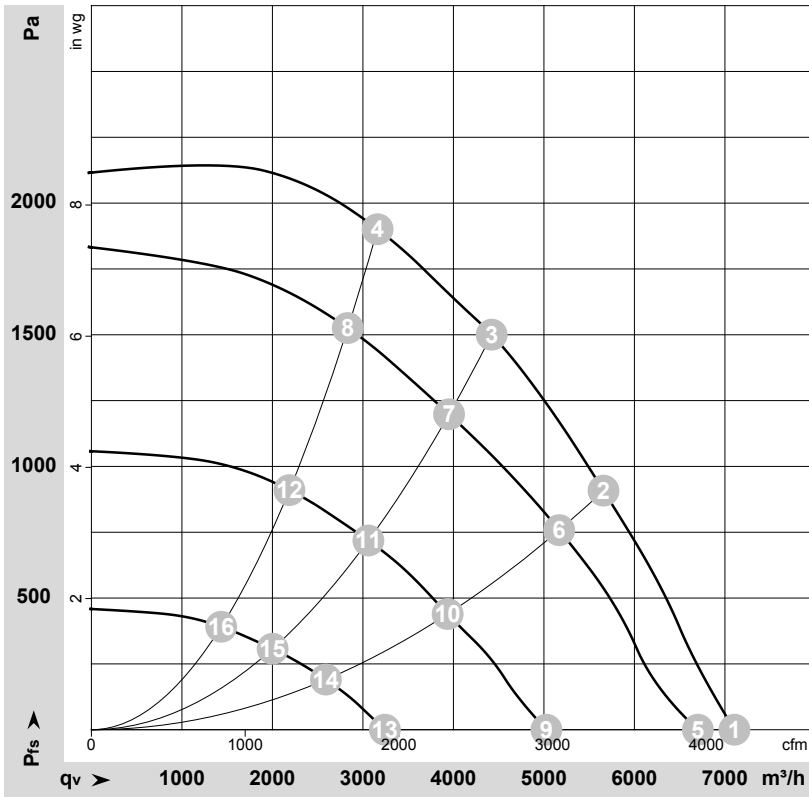

$\rho = 1.177 \text{ kg/m}^3 \pm 2 \%$

Measurement: LU-176710-1

Air performance measured as per ISO 5801 Installation category A. For detailed information on the measuring set-up, please contact ebmpapst. Suction-side noise levels: LwA measured as per ISO 13347 / LpA measured with 1m distance to fan axis. The values given are valid under the measuring conditions mentioned above and may vary according to the actual installation situation. With any deviation from the standard set-up, the specific values have to be checked and reviewed with the unit installed.

## Measured values

	U	f	n	P <sub>ed</sub>	I	LpA <sub>in</sub>	LwA <sub>in</sub>	LwA <sub>out</sub>	q <sub>v</sub>	P <sub>fs</sub>	q <sub>v</sub>	P <sub>fs</sub>
	V	Hz	min <sup>-1</sup>	W	A	dB(A)	dB(A)	dB(A)	m <sup>3</sup> /h	Pa	cfm	inH <sub>2</sub> O
1	400	50	4000	1707	2.66	95	102	102	7105	0	4180	0.00
2	400	50	4000	2611	4.03	85	92	95	5660	900	3330	3.61
3	400	50	4000	2943	4.53	82	89	93	4425	1500	2605	6.02
4	400	50	4000	2950	4.60	84	92	94	3160	1900	1860	7.63
5	400	50	3795	1414	2.22	94	100	100	6700	0	3945	0.00
6	400	50	3655	1998	3.09	83	89	92	5170	762	3040	3.06
7	400	50	3585	2078	3.21	79	86	91	3950	1198	2325	4.81
8	400	50	3610	2103	3.24	79	88	91	2835	1529	1665	6.14
9	400	50	2865	671	1.18	84	92	94	5025	0	2960	0.00
10	400	50	2810	957	1.57	75	82	86	3935	438	2315	1.76
11	400	50	2795	1019	1.66	72	80	84	3060	719	1800	2.89
12	400	50	2790	1028	1.67	73	80	85	2190	912	1290	3.66
13	400	50	1880	244	0.52	72	82	82	3245	0	1910	0.00
14	400	50	1840	320	0.65	63	72	76	2590	191	1525	0.77
15	400	50	1830	340	0.68	62	70	75	2000	308	1180	1.24
16	400	50	1830	343	0.68	63	70	75	1435	392	845	1.57

U = Supply voltage · f = Frequency · n = Speed (rpm) · P<sub>ed</sub> = Power input · I = Current draw · LpA<sub>in</sub> = Sound pressure level inlet side · LwA<sub>in</sub> = Sound power level inlet side · LwA<sub>out</sub> = Sound power level outlet side  
 q<sub>v</sub> = Air flow · p<sub>fs</sub> = Pressure increase

