

AC axial fan

sickled blades (S series), single inlet

Wall ring with guard grille

ASIA PACIFIC SHENGRUI LIMITED

Phone +00852 56261528

info@apacfan.com

www.apacfan.com



Nominal data

Type	W4D400-DP12-41				
Motor	M4D074-EI				
Phase		3~	3~	3~	3~
Nominal voltage	VAC	380	400	400	480
Connection		Y	Y	Y	Y
Frequency	Hz	50	50	60	60
Type of data definition		fa	fa	fa	fa
Valid for approval / standard		CE	CE	CE	CE
Speed	min ⁻¹	1430	1450	1690	1640
Power input	W	145	135	185	250
Current draw	A	0.48	0.44	0.39	0.6
Max. back pressure	Pa	130	150	120	130
Min. ambient temperature	°C	-25	-25	-25	-25
Max. ambient temperature	°C	60	60	60	55
Starting current	A	1.7	1.7	1.7	

ml = Max. load · me = Max. efficiency · fa = Running at free air · cs = Customer specs · cu = Customer unit

Subject to alterations

Data according to ErP directive

Installation category	A
Efficiency category	Static
Variable speed drive	No
Specific ratio*	1.00

* Specific ratio = $1 + p_{fs} / 100\,000\text{ Pa}$

		Actual	Request 2013	Request 2015
Overall efficiency η_{es}	%	32.7	25.1	29.1
Efficiency grade N		43.6	36	40
Power input P_e	kW	0.19		
Air flow q_v	m ³ /h	2595		
Pressure increase p_{fs}	Pa	91		
Speed n	min ⁻¹	1415		

Data definition with optimum efficiency.

LU-27622

The ErP data is determined using a motor-impeller combination in a standardised measurement configuration.



AC axial fan

sickled blades (S series), single inlet

Wall ring with guard grille

Technical features

Mass	9.4 kg
Size	400 mm
Surface of rotor	Coated in black
Material of blades	Sheet steel, coated in black
Material of wall ring	Sheet steel, galvanised and coated in black plastic (RAL 9005)
Material of guard grille	Steel, coated in black plastic (RAL9005)
Number of blades	5
Direction of air flow	"V"
Direction of rotation	Counter-clockwise, seen on rotor
Type of protection	IP 44; Depending on installation and position as per EN 60034-5
Insulation class	"F"
Humidity class	F2-2
Max. permissible ambient motor temp. (transp./ storage)	+ 80 °C
Min. permissible ambient motor temp. (transp./storage)	- 40 °C
Mounting position	Shaft horizontal or rotor on bottom; rotor on top on request
Condensate discharge holes	Rotor-side
Operation mode	S1
Motor bearing	Ball bearing
Touch current acc. IEC 60990 (measuring network Fig. 4, TN system)	< 0.75 mA
Motor protection	Thermal overload protector (TOP) wired internally
Cable exit	Variable
Protection class	I (if protective earth is connected by customer)
Product conforming to standard	CE
Approval	CSA C22.2 Nr.100; UL 1004-1

AC axial fan

sickled blades (S series), single inlet

Wall ring with guard grille

Product drawing

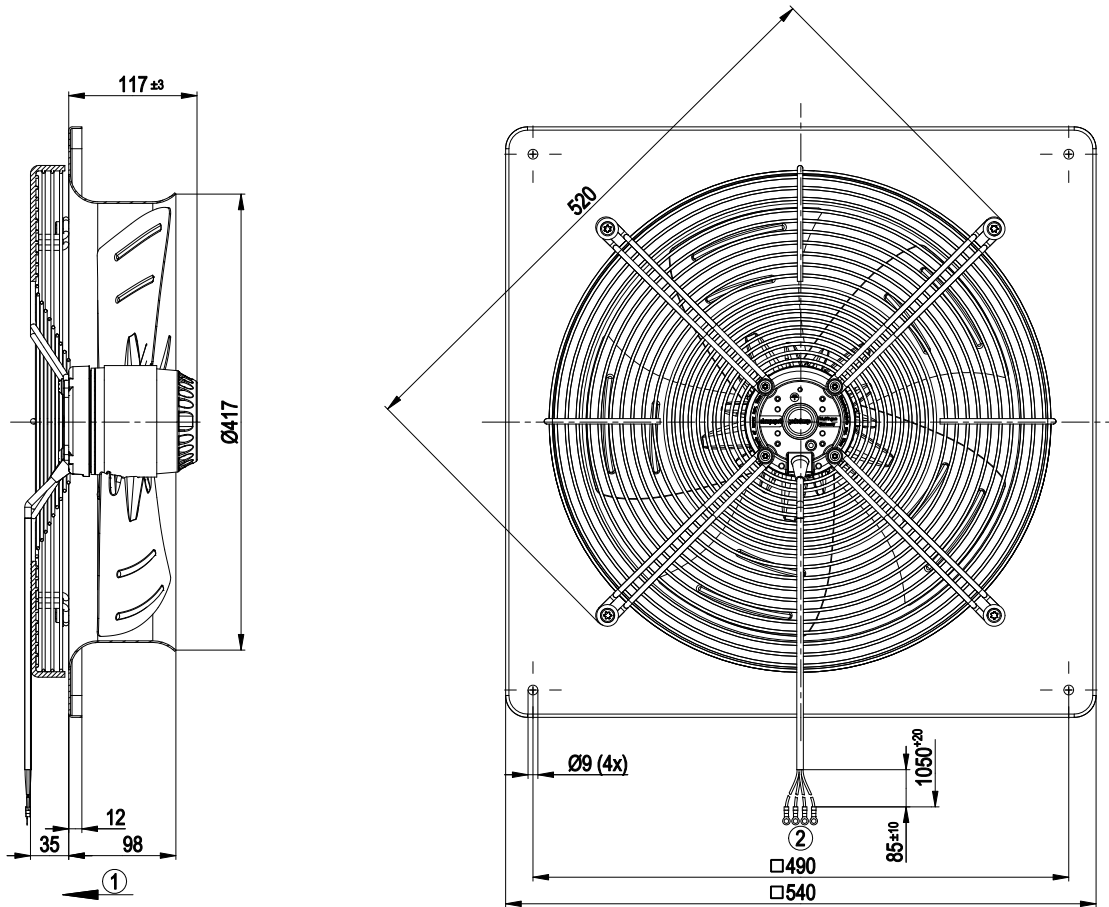

- | | |
|---|---|
| 1 | Direction of air flow "V" |
| 2 | Connection line PFA AWG18, 1x lead tip crimped, connection line PFA AWG20, 3x lead tips crimped |

AC axial fan

sickled blades (S series), single inlet

Wall ring with guard grille

Connection screen

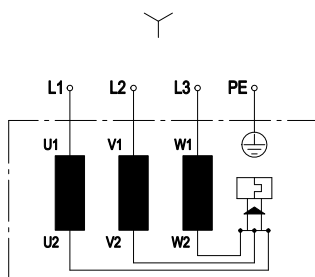

Change direction of rotation by reversing two phases

	Three-phase motor	Y	Star connection	L1	= U1 = black
L2	= V1 = blue	L3	= W1 = brown	PE	green / yellow

AC axial fan

sickled blades (S series), single inlet

Wall ring with guard grille

Charts: Air flow 50 Hz

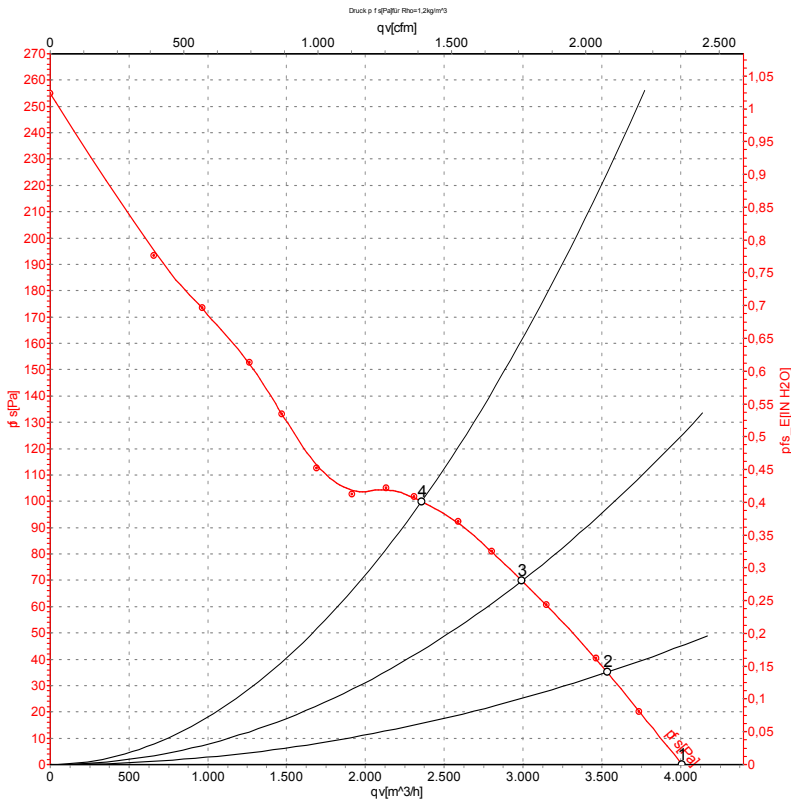

Air performance measured as per ISO 5801 Installation category A. For detailed information on the measuring set-up, please contact ebm-papst. Suction-side noise levels: LwA measured as per ISO 13347 / LpA measured with 1m distance to fan axis. The values given are valid under the measuring conditions mentioned above and may vary according to the actual installation situation. With any deviation from the standard set-up, the specific values have to be checked and reviewed with the unit installed.

Measured values

	Conn.	U	f	n	Pe	I	LpA _{in}	LwA _{in}	qv	p _{fs}
		V	Hz	min ⁻¹	W	A	dB(A)	dB(A)	m ³ /h	Pa
1	Y	400	50	1450	135	0.44	65	74	4000	0
2	Y	400	50	1435	161	0.47	65	73	3535	35
3	Y	400	50	1420	182	0.49	65	72	2995	70
4	Y	400	50	1410	203	0.50	67	74	2355	100

Conn. = Connection · U = Supply voltage · f = Frequency · n = Speed · Pe = Power input · I = Current draw · LpA_{in} = Sound pressure level inlet side · LwA_{in} = Sound power level inlet side
 qv = Air flow · p_{fs} = Pressure increase



AC axial fan

sickled blades (S series), single inlet

Wall ring with guard grille

Charts: Air flow 60 Hz

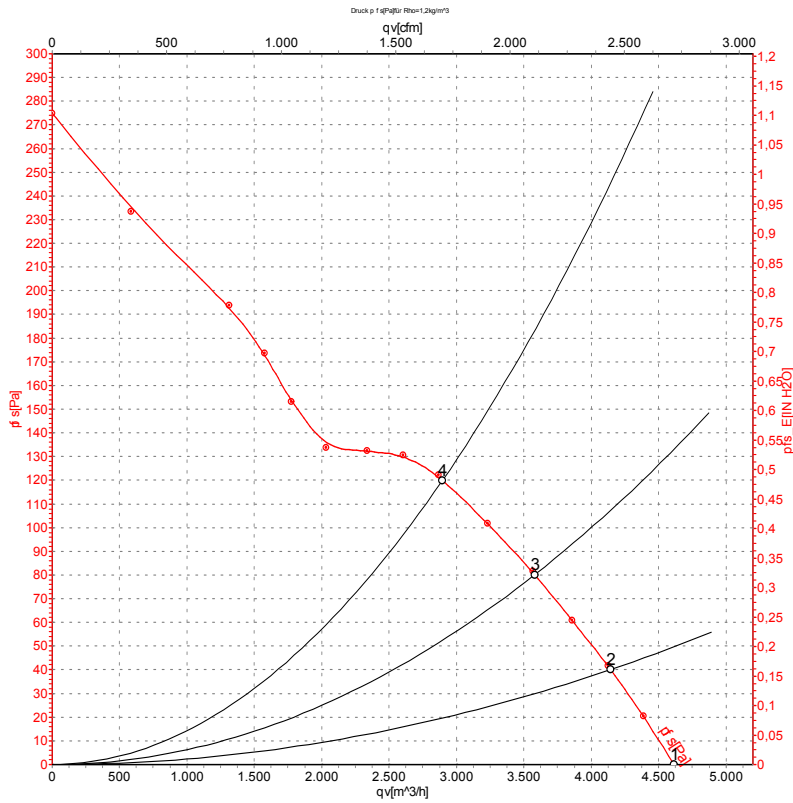

Air performance measured as per ISO 5801 Installation category A. For detailed information on the measuring set-up, please contact ebmpapst. Suction-side noise levels: L_{wA} measured as per ISO 13347 / L_{pA} measured with 1m distance to fan axis. The values given are valid under the measuring conditions mentioned above and may vary according to the actual installation situation. With any deviation from the standard set-up, the specific values have to be checked and reviewed with the unit installed.

Measured values

	Conn.	U	f	n	P_e	I	$L_{pA_{in}}$	$L_{wA_{in}}$	q_v	p_{fs}
		V	Hz	min^{-1}	W	A	dB(A)	dB(A)	m^3/h	Pa
1	Y	400	60	1690	185	0.39	69	76	4615	0
2	Y	400	60	1660	223	0.45	70	76	4145	40
3	Y	400	60	1635	256	0.49	69	76	3580	80
4	Y	400	60	1605	290	0.54	70	76	2895	120

Conn. = Connection · U = Supply voltage · f = Frequency · n = Speed · P_e = Power input · I = Current draw · $L_{pA_{in}}$ = Sound pressure level inlet side · $L_{wA_{in}}$ = Sound power level inlet side
 q_v = Air flow · p_{fs} = Pressure increase

