

## ASIA PACIFIC SHENGRUI LIMITED

Phone +00852 56261528

info@apacfan.com

www.apacfan.com

## Nominal data

Type	W2E250-HL08-07			
Motor	M2E068-CF			
Phase		1~	1~	1~
Nominal voltage	VAC	115	115	115
Frequency	Hz	50	60	60
Type of data definition		fa	fa	fa
Valid for approval / standard		CE	CE	UL 2111
Speed	min <sup>-1</sup>	2500	2650	2650
Power input	W	120	165	175
Current draw	A	1.05	1.45	1.47
Motor capacitor	μF	12	12	12
Capacitor voltage	VDB	220	220	220
Max. back pressure	Pa	130	90	90
Min. ambient temperature	°C	-25	-25	-25
Max. ambient temperature	°C	50	30	30
Starting current	A	1.82	1.8	1.8

ml = max. load · me = max. efficiency · fa = running at free air · cs = customer specs · cu = customer unit  
Subject to alterations



### Technical features

<b>Mass</b>	2.78 kg
<b>Size</b>	250 mm
<b>Surface of rotor</b>	Coated in black
<b>Material of blades</b>	Sheet steel, coated in black
<b>Material of wall ring</b>	Die-cast aluminium
<b>Number of blades</b>	7
<b>Direction of air flow</b>	"V"
<b>Direction of rotation</b>	Counter-clockwise, seen on rotor
<b>Type of protection</b>	IP 44
<b>Insulation class</b>	"B"
<b>Humidity class</b>	F1-2
<b>Max. permissible ambient motor temp. (transp./ storage)</b>	+ 80 °C
<b>Min. permissible ambient motor temp. (transp./storage)</b>	- 40 °C
<b>Mounting position</b>	Any
<b>Condensate discharge holes</b>	None
<b>Operation mode</b>	S1
<b>Motor bearing</b>	Ball bearing
<b>Touch current acc. IEC 60990 (measuring network Fig. 4, TN system)</b>	< 0.75 mA
<b>Electrical leads</b>	Via terminal strips, integrated capacitor connected via terminal strips
<b>Motor protection</b>	Thermal overload protector (TOP) wired internally
<b>Cable exit</b>	Variable
<b>Protection class</b>	I (if protective earth is connected by customer)
<b>Product conforming to standard</b>	EN 60335-1; CE
<b>Approval</b>	UL 2111; CSA C22.2 Nr.77

## Product drawing

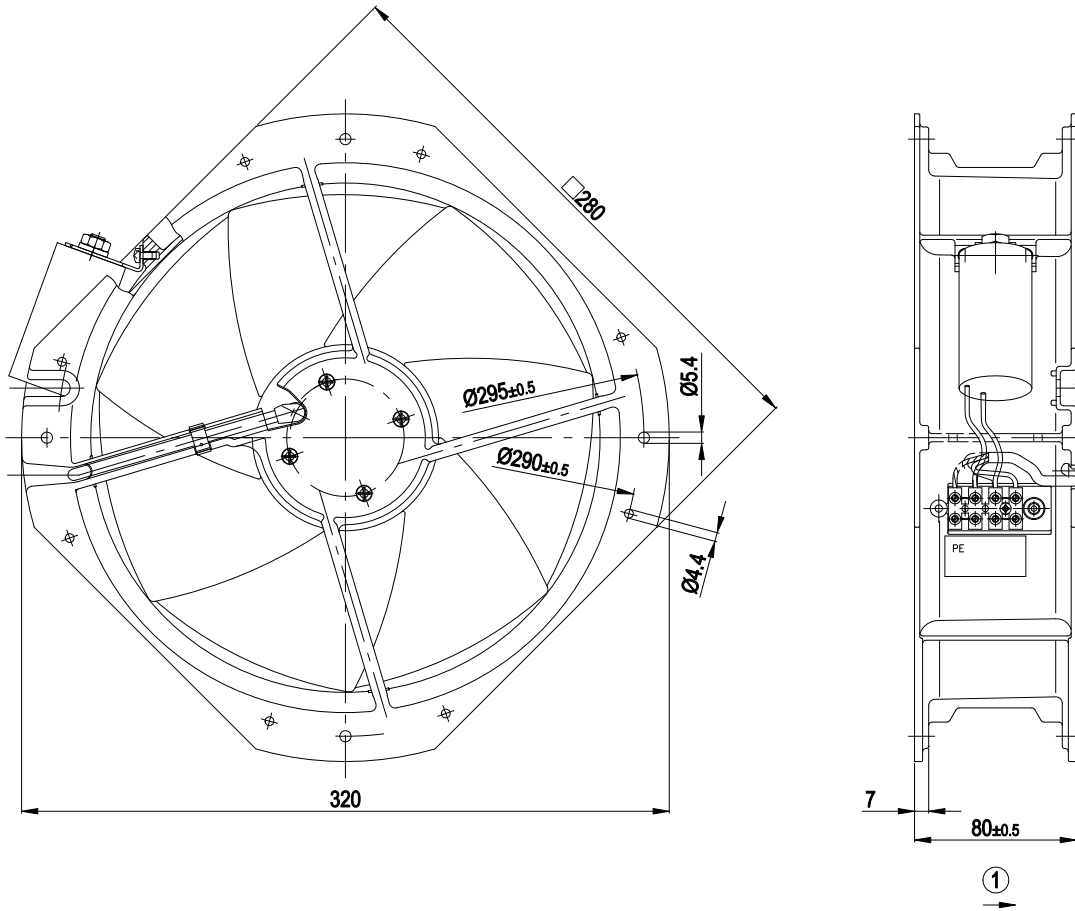

1 Direction of air flow "V"

## Connection screen

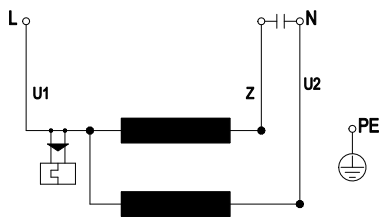

U1	blue	Z	brown	U2	black
PE	green/yellow				

## Charts: Air flow 50 Hz

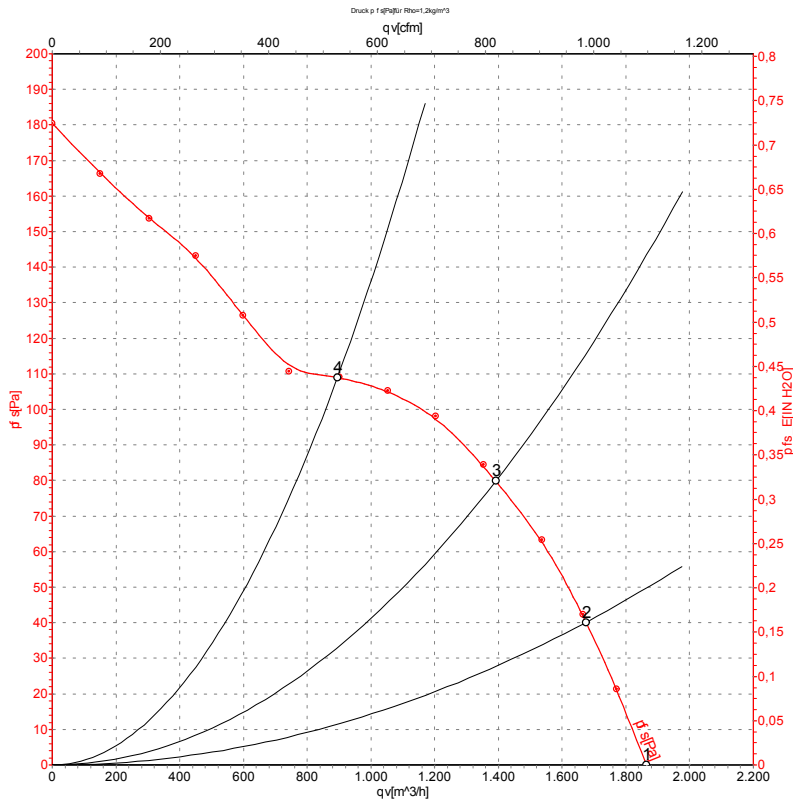

Measurement: LU-63607

Air performance measured as per ISO 5801 Installation category A. For detailed information on the measuring set-up, please contact ebm-papst. Suction-side noise levels: LwA measured as per ISO 13347 / LpA measured with 1m distance to fan axis. The values given are valid under the measuring conditions mentioned above and may vary according to the actual installation situation. With any deviation from the standard set-up, the specific values have to be checked and reviewed with the unit installed.

## Measured values

	U	f	n	P <sub>e</sub>	I	qv	P <sub>fs</sub>
	V	Hz	min <sup>-1</sup>	W	A	m <sup>3</sup> /h	Pa
1	115	50	2500	120	1.05	1865	0
2	115	50	2445	128	1.12	1675	40
3	115	50	2355	138	1.20	1390	80
4	115	50	2265	147	1.27	895	110

U = Supply voltage · f = Frequency · n = Speed · P<sub>e</sub> = Power input · I = Current draw · qv = Air flow · P<sub>fs</sub> = Pressure increase



## Charts: Air flow 60 Hz

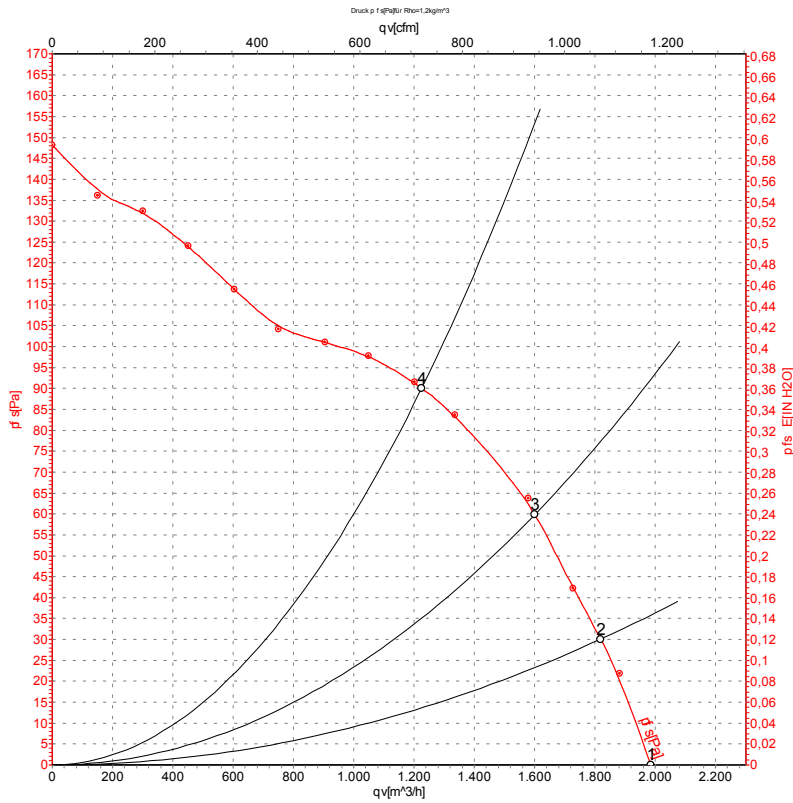

Measurement: LU-63606

Air performance measured as per ISO 5801 Installation category A. For detailed information on the measuring set-up, please contact ebmpapst. Suction-side noise levels: L<sub>wA</sub> measured as per ISO 13347 / L<sub>pA</sub> measured with 1m distance to fan axis. The values given are valid under the measuring conditions mentioned above and may vary according to the actual installation situation. With any deviation from the standard set-up, the specific values have to be checked and reviewed with the unit installed.

## Measured values

	U	f	n	P <sub>e</sub>	I	qv	P <sub>fs</sub>
	V	Hz	min <sup>-1</sup>	W	A	m³/h	Pa
1	115	60	2650	165	1.45	1985	0
2	115	60	2560	174	1.51	1820	30
3	115	60	2440	178	1.55	1600	60
4	115	60	2275	183	1.59	1225	90

U = Supply voltage · f = Frequency · n = Speed · P<sub>e</sub> = Power input · I = Current draw · qv = Air flow · P<sub>fs</sub> = Pressure increase

