

S4D500-AD03-01

# AC axial fan

sickled blades (S series)  
with guard grille for short nozzle

## ASIA PACIFIC SHENGRUI LIMITED

Phone +00852 56261528

info@apacfan.com

www.apacfan.com

### Nominal data

Type	S4D500-AD03-01				
Motor	M4D110-GF				
Phase		3~	3~	3~	3~
Nominal voltage	VAC	400	400	480	480
Connection		$\Delta$	Y	$\Delta$	Y
Frequency	Hz	50	50	60	60
Type of data definition		ml	ml	ml	ml
Valid for approval / standard		CE	CE	CE	CE
Speed	min <sup>-1</sup>	1325	1035	1570	1170
Power input	W	820	550	1220	770
Current draw	A	1.59	0.95	1.86	1.13
Max. back pressure	Pa	160	100	150	84
Min. ambient temperature	°C	-40	-40	-40	-40
Max. ambient temperature	°C	80	80	50	50
Starting current	A	6.5	2	7.5	2.2

ml = max. load · me = max. efficiency · fa = running at free air · cs = customer specs · cu = customer unit  
Subject to alterations

### Data according to ErP directive

Installation category	A
Efficiency category	Static
Variable speed drive	No
Specific ratio*	1.00

\* Specific ratio =  $1 + p_{fs} / 100\,000\text{ Pa}$

	Actual	Request 2013	Request 2015
Overall efficiency $\eta_{es}$	31.3	29	33
Efficiency grade N	38.3	36	40
Power input $P_e$	kW	0.77	
Air flow $q_v$	m <sup>3</sup> /h	6045	
Pressure increase $p_{fs}$	Pa	144	
Speed n	min <sup>-1</sup>	1335	

Data established at point of optimum efficiency



ebmpapst

S4D500-AD03-01

# AC axial fan

sickled blades (S series)  
with guard grille for short nozzle

## Technical features

Mass	13.4 kg
Size	500 mm
Surface of rotor	Cast in aluminium
Material of terminal box	PP plastic
Material of blades	Aluminium sheet
Material of guard grille	Steel, coated in black plastic (RAL9005)
Number of blades	5
Blade angle	0
Direction of air flow	"V"
Direction of rotation	Counter-clockwise, seen on rotor
Type of protection	IP 54
Insulation class	"F"
Humidity class	F3-1
Max. permissible ambient motor temp. (transp./ storage)	+ 80 °C
Min. permissible ambient motor temp. (transp./storage)	- 40 °C
Mounting position	Shaft horizontal or rotor on bottom; rotor on top on request
Condensate discharge holes	Rotor-side
Operation mode	S1
Motor bearing	Ball bearing
Touch current acc. IEC 60990 (measuring network Fig. 4, TN system)	<= 3.5 mA
Electrical leads	Via terminal box
Motor protection	Thermal overload protector (TOP) brought out
Cable exit	Axial
Protection class	I (if protective earth is connected by customer)
Product conforming to standard	EN 61800-5-1; CE
Approval	GOST; VDE; CCC



S4D500-AD03-01

# AC axial fan

sickled blades (S series)

with guard grille for short nozzle

## Product drawing

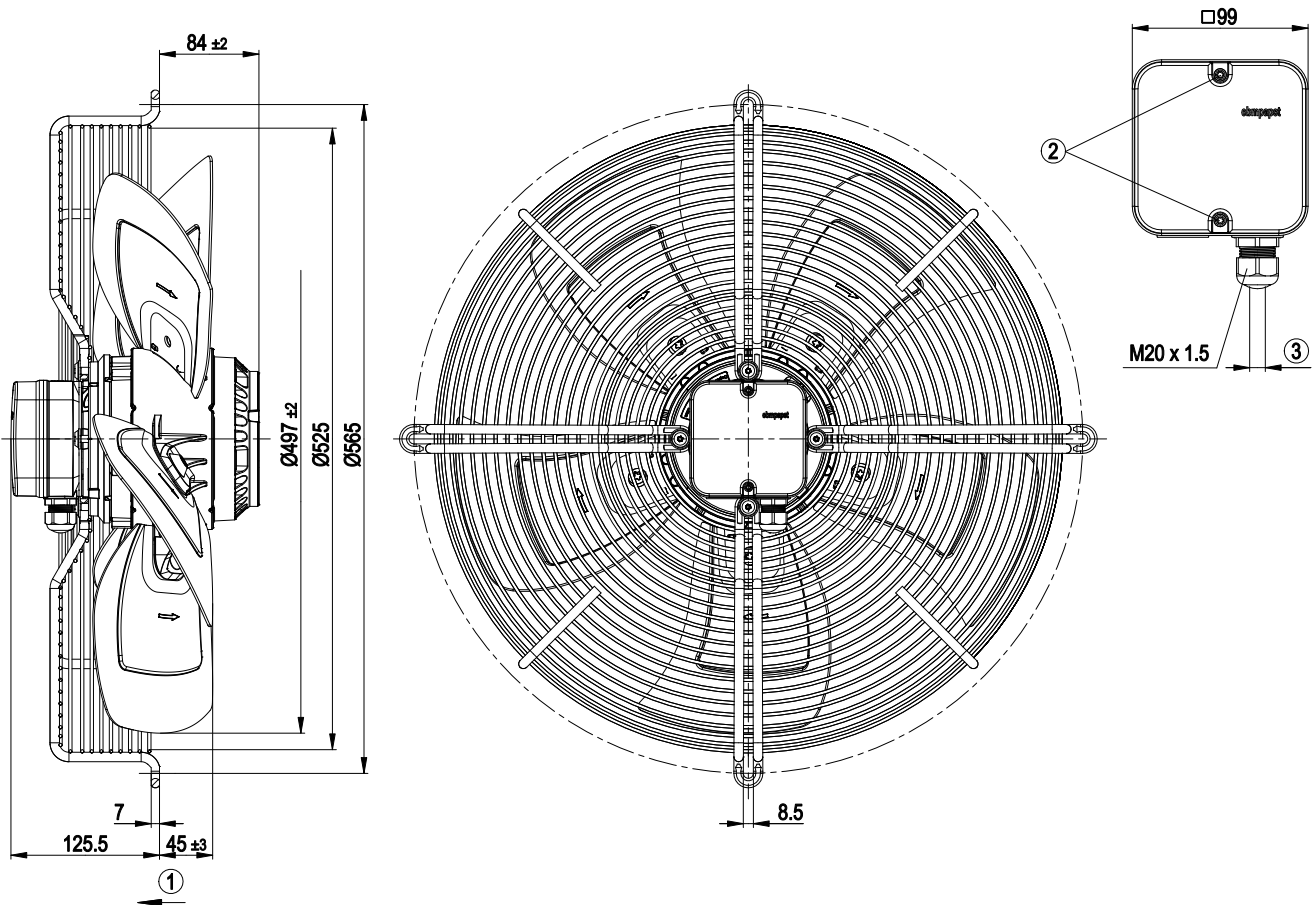

- |   |  |
|---|--|
| 1 | Direction of air flow "V"  |
| 2 | Tightening torque 1.5±0.2 Nm                                       |
| 3 | Cable diameter: min. 6 mm, max. 12 mm; tightening torque: 2±0.3 Nm |



# AC axial fan

sickled blades (S series)  
with guard grille for short nozzle

## Connection screen

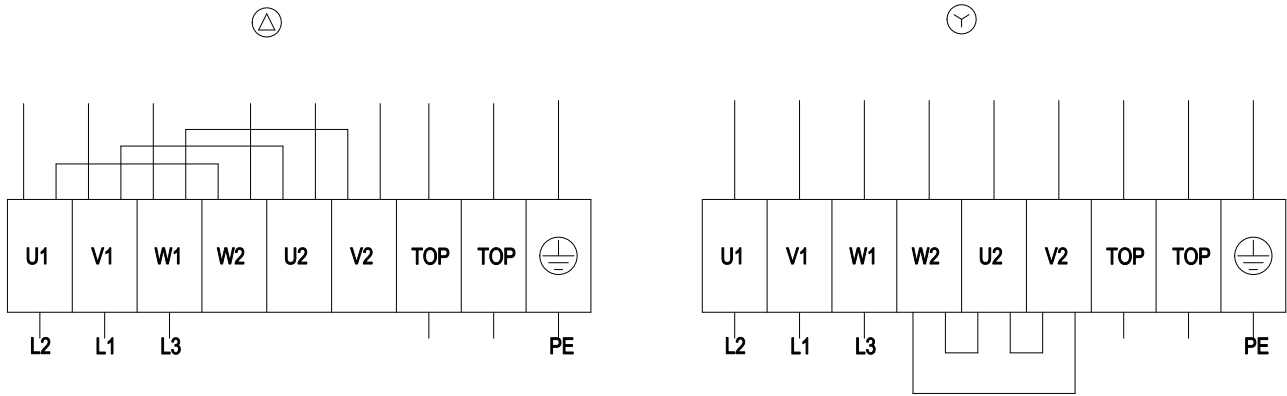

Δ	Delta connection	Y	Star connection	L1	= V1 = blue
L2	= U1 = black	L3	= W1 = brown	W2	yellow
U2	green	V2	white	TOP	2 x grey
PE	green/yellow				

# AC axial fan

sickled blades (S series)  
with guard grille for short nozzle

## Charts: Air flow 50 Hz Δ

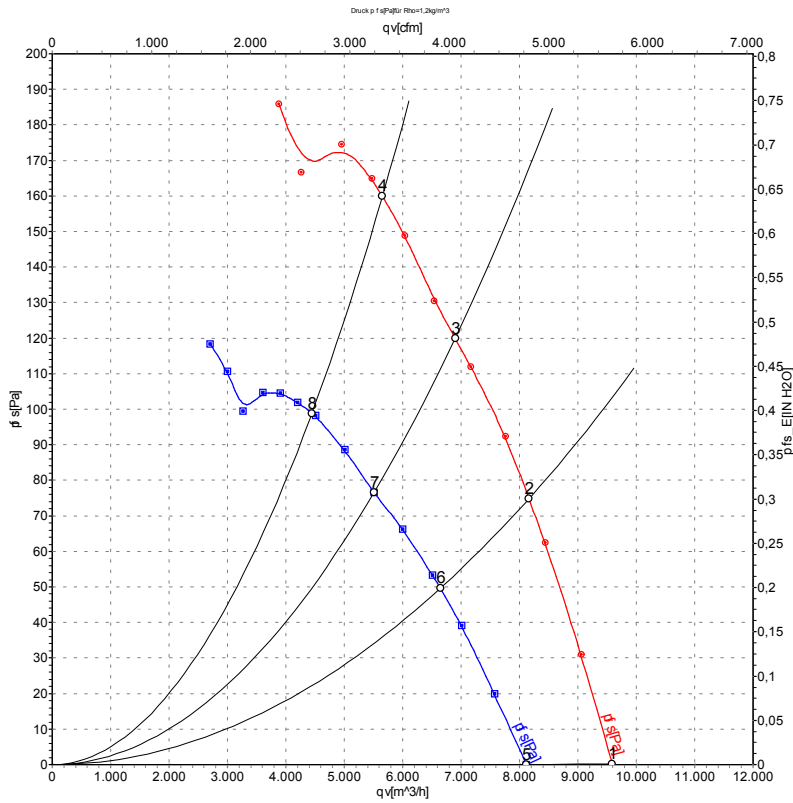

Measurement: LU-100710  
Measurement: LU-100714

Air performance measured as per ISO 5801 Installation category A. For detailed information on the measuring set-up, please contact ebm-papst. Suction-side noise levels: L<sub>wA</sub> measured as per ISO 13347 / L<sub>pA</sub> measured with 1m distance to fan axis. The values given are valid under the measuring conditions mentioned above and may vary according to the actual installation situation. With any deviation from the standard set-up, the specific values have to be checked and reviewed with the unit installed.

## Measured values

	Conn.	U	f	n	P <sub>e</sub>	I	L <sub>pA<sub>in</sub></sub>	L <sub>wA<sub>in</sub></sub>	qv	p <sub>fs</sub>
		V	Hz	min <sup>-1</sup>	W	A	dB(A)	dB(A)	m <sup>3</sup> /h	Pa
1	Δ	400	50	1380	620	1.30	71	77	9590	0
2	Δ	400	50	1360	700	1.38	71	77	8160	75
3	Δ	400	50	1345	749	1.44	71	78	6900	120
4	Δ	400	50	1325	820	1.59	73	80	5655	160
5	Y	400	50	1160	455	0.77	73	80	8120	0
6	Y	400	50	1105	498	0.84	73	80	6645	50
7	Y	400	50	1075	519	0.87	73	80	5515	76
8	Y	400	50	1035	550	0.95	73	80	4445	100

Conn. = Connection · U = Supply voltage · f = Frequency · n = Speed · P<sub>e</sub> = Power input · I = Current draw · L<sub>pA<sub>in</sub></sub> = Sound pressure level inlet side · L<sub>wA<sub>in</sub></sub> = Sound power level inlet side  
qv = Air flow · p<sub>fs</sub> = Pressure increase



# AC axial fan

sickled blades (S series)  
with guard grille for short nozzle

## Charts: Air flow 60 Hz Δ

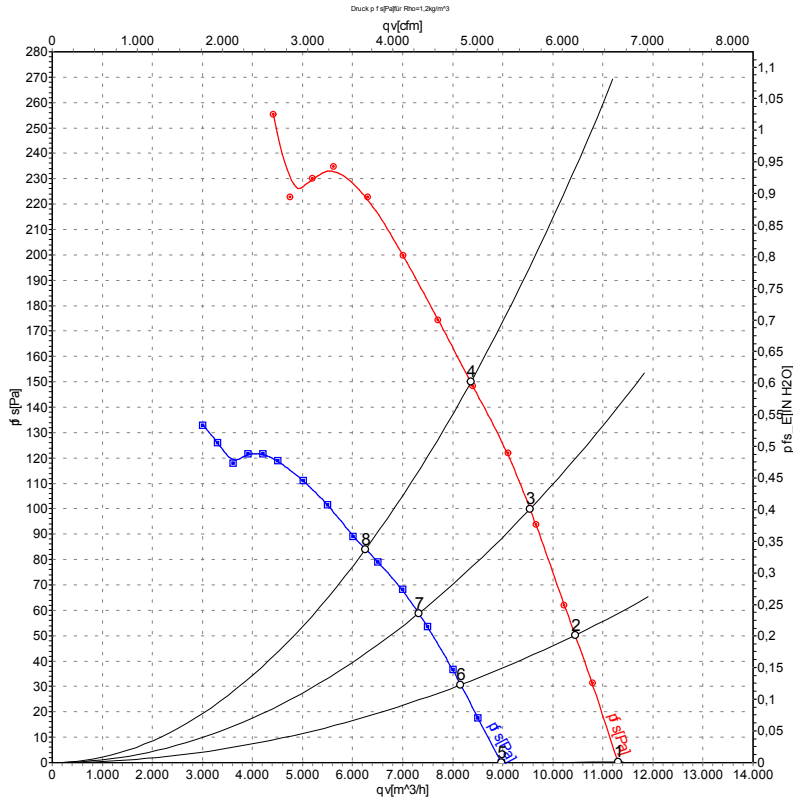

Measurement: LU-100711  
Measurement: LU-100715

Air performance measured as per ISO 5801 Installation category A. For detailed information on the measuring set-up, please contact ebm-papst. Suction-side noise levels: LwA measured as per ISO 13347 / LpA measured with 1m distance to fan axis. The values given are valid under the measuring conditions mentioned above and may vary according to the actual installation situation. With any deviation from the standard set-up, the specific values have to be checked and reviewed with the unit installed.

## Measured values

	Conn.	U	f	n	P <sub>e</sub>	I	LpA <sub>in</sub>	LwA <sub>in</sub>	qv	p <sub>fs</sub>
		V	Hz	min <sup>-1</sup>	W	A	dB(A)	dB(A)	m <sup>3</sup> /h	Pa
1	Δ	480	60	1620	1000	1.55	74	80	11300	0
2	Δ	480	60	1605	1069	1.63	74	80	10440	50
3	Δ	480	60	1590	1138	1.70	74	80	9545	100
4	Δ	480	60	1570	1220	1.86	75	81	8360	150
5	Y	480	60	1280	695	0.98	75	81	8970	0
6	Y	480	60	1250	723	1.02	75	81	8160	31
7	Y	480	60	1210	748	1.06	75	81	7320	59
8	Y	480	60	1170	770	1.13	75	81	6260	84

Conn. = Connection · U = Supply voltage · f = Frequency · n = Speed · P<sub>e</sub> = Power input · I = Current draw · LpA<sub>in</sub> = Sound pressure level inlet side · LwA<sub>in</sub> = Sound power level inlet side  
qv = Air flow · p<sub>fs</sub> = Pressure increase

