

5314 /2TD HHP

## DC axial compact fan



### ASIA PACIFIC SHENGRUI LIMITED

Phone +00852 56261528

info@apacshengrui.com

www.apacfan.com

### Nominal data

Type	5314 /2TD HHP	
Nominal voltage	VDC	24
Nominal voltage range	VDC	16 .. 36
Speed (rpm)	min <sup>-1</sup>	7000
Power consumption	W	67
Min. ambient temperature	°C	-20
Max. ambient temperature	°C	70
Air flow	m <sup>3</sup> /h	490
Sound power level	B	8.1
Sound pressure level	dB(A)	75

ml = Max. load · me = Max. efficiency · fa = Free air · cs = Customer specification · ce = Customer equipment  
Subject to change



**Technical description**

<b>General description</b>	Power consumption when wide open; these values may be considerably higher at the operating point.
<b>Impeller material</b>	Glass-fiber reinforced PA plastic
<b>Weight</b>	0.900 kg
<b>Dimensions</b>	140 x 140 x 51 mm
<b>Housing material</b>	Die-cast aluminum
<b>Airflow direction</b>	Intake over struts
<b>Direction of rotation</b>	Counterclockwise, viewed toward rotor
<b>Storage</b>	Ball bearing
<b>Service life L10 at 40 °C</b>	62500 h
<b>Service life L10 at maximum temperature</b>	30000 h
<b>Cable</b>	With leads AWG 20 and AWG 22, TR 64
<b>Motor protection</b>	Protection against reverse polarity and blocked rotor.

Product drawing

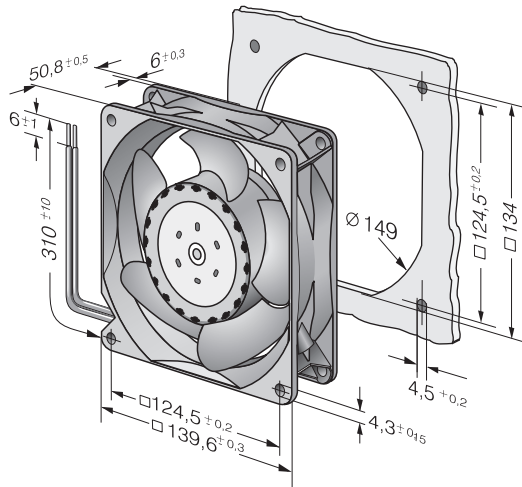

## Curves: Air performance

