



The engineer's choice

ebmpapst

9906

INDEX

1	General	3
2	Mechanics	3
2.1	GENERAL	3
2.2	CONNECTIONS	4
3	Operating Data	5
3.1	ELECTRICAL OPERATING DATA	5
3.2	OPERATING DATA - ELECTRICAL INTERFACE -OUTPUT	6
3.3	ELECTRICAL FEATURES	6
3.4	AERODYNAMIC	6
3.5	SOUND DATA	7
4	Environment	8
4.1	GENERAL	8
4.2	CLIMATIC REQUIREMENTS*)	8
5	Safety	9
5.1	ELECTRICAL SAFETY	9
5.2	APPROVAL TESTS	9
6	Reliability	9
6.1	GENERAL	9

1 General

Fan type	Fan
Rotational direction looking at rotor	counterclockwise
Airflow direction	Air outlet over struts
Bearing system	Ball bearing
Mounting position	any
Balancing grade	40,0

2 Mechanics**2.1 General**

Width	119,0 mm	
Height	119,0 mm	
Depth	25,0 mm	
Diameter	0,0 mm	
Weight	0,320 kg	
Housing material	Metal	
Impeller material	Plastic	
Max. torque when mounted across both mounting flanges	wire outlet corner: 110 Ncm remaining corners: 380 Ncm	
Screw size	ISO 4762 - M4 degreased, without an additional brace and without washer	

2.2 Connections

Electrical connection	Plug	
Plug	see drawing	
Contact	see drawing	

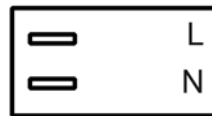

3 Operating Data

3.1 Electrical Operating Data

Measurement conditions: Normal air density = 1,2 kg/m³; Temperature 23°C +/- 3°C; Motor axis horizontal; warm-up time before measuring 5 minutes (unless otherwise specified).
In the intake and outlet area should not be any solid obstruction within 0,5 m.

$\Delta p = 0$: corresp. to free air flow (see section 3.4)

I: corresp. to RMS line current

Features	Condition	Symbol	Values	
Frequency	$\Delta p = 0$	f	50 Hz	60 Hz
Nominal voltage	$\Delta p = 0$	U_N	115,0 V	115,0 V
Tolerance			+ 6,0 % - 10,0 %	+ 6,0 % - 10,0 %
Power consumption	$\Delta p = 0$	P	14,0 W	12,0 W
Tolerance			+ 5,0 % - 10,0 %	+ 5,0 % - 10,0 %
Speed	$\Delta p = 0$	n	2.450 1/min	2.850 1/min
Tolerance			+/- 3,0 %	+/- 3,0 %

3.2 Operating Data - Electrical Interface -Output

Tacho type	None
------------	------

3.3 Electrical Features

Locked rotor protection	Impedance
Locked rotor current at U_n	

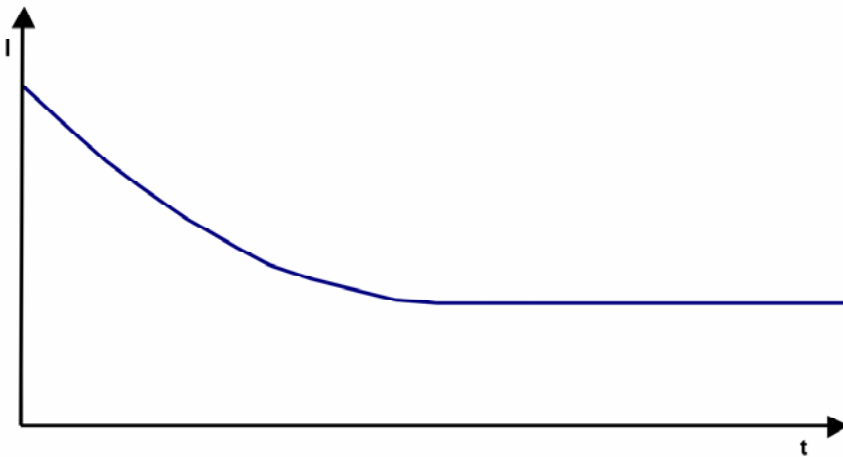

3.4 Aerodynamic

Measurement conditions: Measured with a double chamber intake rig acc. to DIN EN ISO 5801.
Normal air density = 1,2 kg/m³; Temperature 23°C +/- 3°C;
In the intake and outlet area should not be any solid obstruction within 0,5 m.

a.) Operation condition:

2.450 1/min at free air flow Frequency: 50 Hz

Max. free-air flow ($\Delta p = 0 / \dot{V} = \text{max.}$)	114,0 m ³ /h
Max. static pressure ($\Delta p = \text{max.} / \dot{V} = 0$)	48 Pa

b.) Operation condition:

2.850 1/min at free air flow Frequency: 60 Hz

Max. free-air flow ($\Delta p = 0 / \dot{V} = \text{max.}$)	130,0 m ³ /h
Max. static pressure ($\Delta p = \text{max.} / \dot{V} = 0$)	38 Pa

3.5 Sound Data

Measurement conditions: Sound pressure level: 1 Meter distance between microphone and the air intake.
 Sound power level: Acc. to DIN 45635 part 38 (ISO 10302)
 Measured in a semianchoic chamber with a background noise level of $L_p(A) < 5 \text{ dB(A)}$
 For further measurement conditions see section 3.4

a.) Operation condition:

2.450 1/min at free air flow

Frequency: 50 Hz

Optimal operating point	84,0 m ³ /h @ 17 Pa	
Sound power level at the optimal operating point	5,0 bel(A)	
Sound pressure level at free air flow, measured in rubber bands	38,0 dB(A)	

b.) Operation condition:

2.850 1/min at free air flow

Frequency: 60 Hz

Optimal operating point	84,0 m ³ /h @ 22 Pa	
Sound power level at the optimal operating point	5,4 bel(A)	
Sound pressure level at free air flow, measured in rubber bands	42,0 dB(A)	

4 Environment

4.1 General

Min. permitted ambient temperature TU min.	-40 °C / 50 Hz -40 °C / 60 Hz	
Max. permitted ambient temperature TU max.	70 °C / 50 Hz 70 °C / 60 Hz	
Min. permitted storage temperature TL min.	-40 °C	
Max. permitted storage temperature TL max.	80 °C	

4.2 Climatic requirements*)

Humidity requirements	humid heat, constant; according to DIN EN 60068-2-78, 14 days	
Water exposure	None	
Radiation exposure	None	
Dust requirements	None	
Salt fog requirements	None	
Harmful gas requirements	None	

*) Permitted application area:

The product is intended for use in sheltered rooms with controlled temperature and controlled humidity. Directly exposure to water must be avoided.

Pollution degree 1 (according DIN EN 60664-1)

There is either no pollution or it occurs only dry, non-conductive pollution. The pollution has no negative impact.

5 Safety

5.1 Electrical Safety

Dielectric strength DIN EN 60950 (VDE 0805) and DIN EN 60335 (VDE 0700) A.) Type test Measuring conditions: After 48h of storage at 95% R.H. and 25°C. No arcing or breakdown is allowed! All connections together to ground.	1000 VAC / 1 Min.
B.) Routine test Measuring conditions: At indoor climate. No arcing or breakdown is allowed! All connections together to ground.	1500 VAC / 1 Sec.
Isolation resistance Measuring conditions: After 48h of storage at 95% R.H. and 25°C measured with U=500 VDC for 1 min.	RI > 50 MOhm
Air and leakage distances	2,0 mm / 1,1 mm
Protection class	I

5.2 Approval Tests

CE	Yes
UL	Yes / UL507, Electric Fans
VDE	Yes / Approval acc. to EN 60335 (VDE 0700) - Safety for household and similar electrical appliances
CSA	Yes / C22.2 No. 113 Fans and Ventilators
CCC	Yes / GB 12350 Safety Requirements for small Power Motors

The approval tests are observed to:

U approval max.: 115 V / f: 50 and 60 Hz @ TU approval max.: 70 °C

6 Reliability

6.1 General

Life expectancy L10 at TU = 40 °C	47.500 h / 50 Hz 52.500 h / 60 Hz	
Life expectancy L10 at TU max.	22.500 h / 50 Hz 25.000 h / 60 Hz	

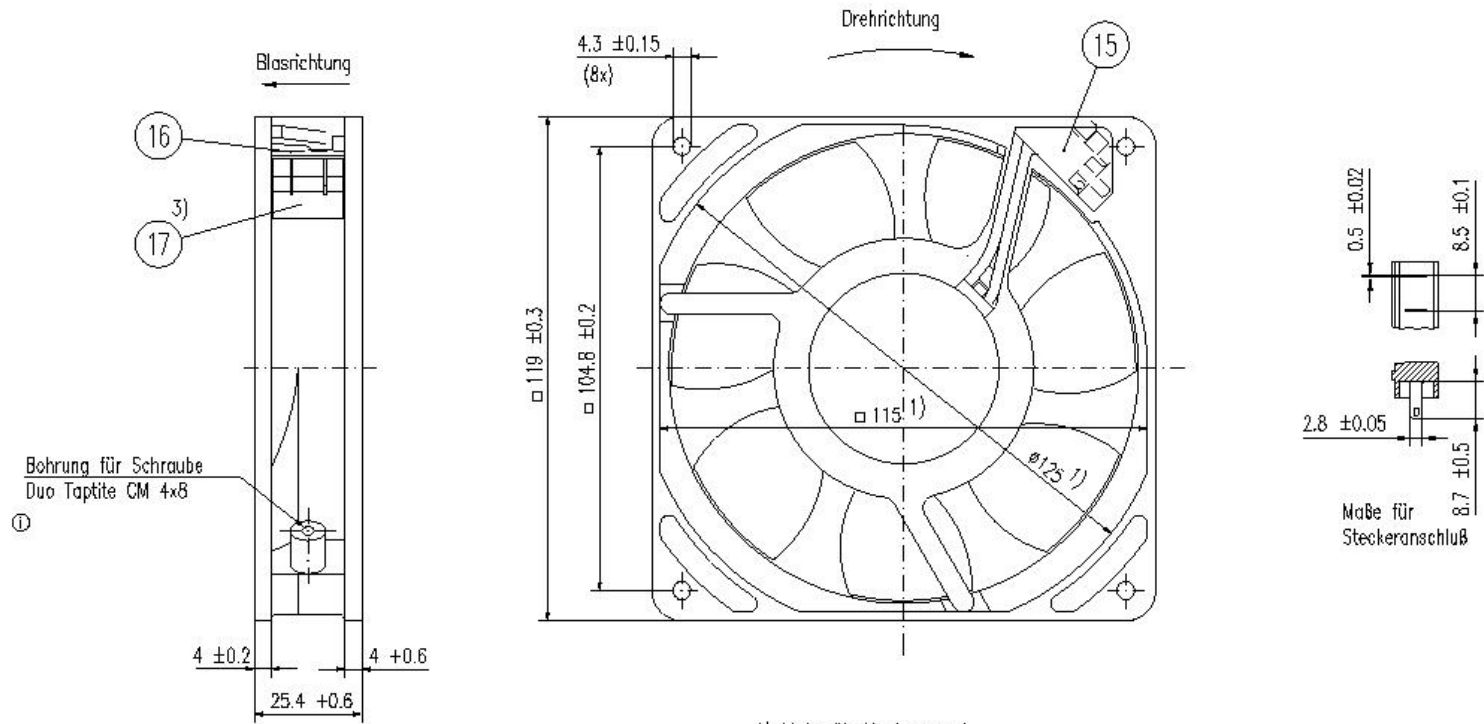

- 1) Maße für Montagewand
- 3) mit Pos. 23 geklebt

Axialspiel bei
 - Kugellagerung (K): 0 (mit Federausgleich)
 - Gleitlagerung (G): 0.1 – 0.6

Tolerierung: DIN 7167				Datum		Name		Artikel		Maßstab	
Allgemeintoleranzen: DIN ISO 2768-mK-E				Erstellt							
				Geprüft							
Index: Änd.-Nr.: Datum: Geändert von: Zur Verwendung in Verteiler freigegeben von:				PAPST PAPST-MOTOREN GmbH & Co KG D-78112 St. Georgen Germany				Zchg.-Nr.		Blatt	
								Ersf.Zchg:			