

Product Data Sheet 6318/2TDHP

ebmpapst

Die Wahl der Ingenieure



6318/2TDHP

INDEX

1	General	3
2	Mechanics	3
2.1	General	3
2.2	Connections	3
3	Operating Data	5
3.1	Operating Data - Electrical Interface - Input	5
3.2	Electrical Operating Data	7
3.3	Operating Data - Electrical Interface -Output	8
3.4	Electrical Features	9
3.5	Aerodynamic	12
3.6	Sound Data	13
4	Environment	13
4.1	General	13
4.2	Climatic requirements*)	13
5	Safety	14
5.1	Electrical Safety	14
5.2	Approval Tests	14
6	Reliability	14
6.1	General	14

1 General

Fan type	Axial fan	
Rotational direction looking at rotor	counterclockwise	
Airflow direction	Air outlet over struts	
Bearing system	Ball bearing	
Mounting position	any	

2 Mechanics**2.1 General**

Depth	51,0 mm	
Diameter	172,0 mm	
Weight	0,875 kg	
Housing material	Metal	
Impeller material	Plastic	
Max. torque when mounted across both mounting flanges	wire outlet corner: 600 Ncm remaining corners: 600 Ncm	
Screw size	ISO 4762 - M4 degreased, without an additional brace and without washer	

2.2 Connections

Electrical connection	Wires	
Length of lead wire	L = 365 mm	
Tolerance	+ - 10,0 mm	
Length of tube	S = 10 mm	
Tolerance	+ - 2,0 mm	
Wire gauge (AWG)	22	
Insulation diameter	1,7 mm	
Contact	see drawing	

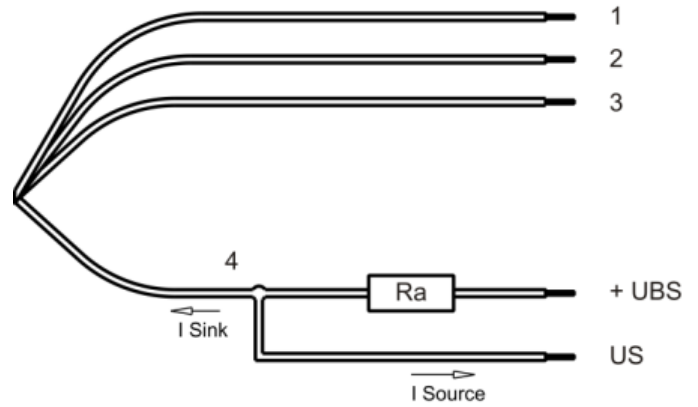

	Colour	Operation
Wire 1	red	+ UB
Wire 2	blue	- GND
Wire 3	violet	PWM
Wire 4	white	Tacho

The auxiliaries shown on the schematic diagram (which are required for the intended use) are not part of our delivery.

3 Operating Data

3.1 Operating Data - Electrical Interface - Input

Control input	PWM
---------------	-----

Features

PWM - Frequency	Typical: 2 kHz
Input frequency range	1 kHz - 20 kHz

Characteristics	<p>Drehzahl / speed [1/min]</p> <p>PWM [%]</p>
Schematics	<p>Lüfter / Fan</p> <p>Kunde / Customer</p> <p>+ UB</p> <p>+ Interne Ref. / + Internal ref.</p> <p>Eingang / Input</p> <p>- GND</p>

The shown pull-up resistor to the internal reference voltage (+5V) has 4.7kOhm.

Speed control:

By puls width modulation (PWM) 0 ... 100%, f: 1...20 kHz
Open collector in relation to signal-ground.

Information to the curve:

0 % - 7% PWM:	0 1/min
7 % PWM:	1000 1/min (Fan on, coming from 0% PWM)
7 % - 10% PWM:	1000 1/min (corresponding to min. speed)
10 % - 90% PWM:	linear increasing curve
90 % - 100% PWM:	5500 1/min (corresponding to max. speed)
7 % - 5 % PWM:	linear decreasing curve (coming from 100% PWM)
5 % PWM:	800 1/min or 0 1/min (Fan off, coming from 100% PWM)

Transistor requirements:

Vce max. $\geq 12V$; Isink max. $\geq 5mA$
Vce sat. $\leq 0,15V$

3.2 Electrical Operating Data

Measurement conditions: Normal air density = 1,2 kg/m³; Temperature 23°C +/- 3°C; Motor axis horizontal; warm-up time before measuring 5 minutes (unless otherwise specified). In the intake and outlet area should not be any solid obstruction within 0,5 m.

$\Delta p = 0$: corresp. to free air flow (see section 3.5)
 I: corresp. to arithm. mean current value

Name	Condition
PWM 0001	PWM: 95 %; f: 2 kHz

Features	Condition	Symbol	Values		
Voltage range	$\Delta p = 0$	U	36,0 V		72,0 V
Nominal voltage	$\Delta p = 0$	U_N		48,0 V	
Power consumption	$\Delta p = 0$	P	28,3 W	38,5 W	39,5 W
Tolerance	PWM 0001		+/- 10,0 %	+/- 10,0 %	+/- 10,0 %
Current consumption	$\Delta p = 0$	I	785 mA	800 mA	550 mA
Tolerance	PWM 0001		+/- 10,0 %	+/- 10,0 %	+/- 10,0 %
Speed	$\Delta p = 0$	n	5.000 1/min	5.500 1/min	5.500 1/min
Tolerance	PWM 0001		+/- 7,5 %	+/- 5,0 %	+/- 5,0 %

100% PWM or broken lead wire (open control input)

Name	Condition
PWM 0002	PWM: 9 %; f: 2 kHz

Features	Condition	Symbol	Values		
Voltage range	$\Delta p = 0$	U	36,0 V		72,0 V
Nominal voltage	$\Delta p = 0$	U_N		48,0 V	
Power consumption	$\Delta p = 0$	P	1,6 W	1,9 W	2,6 W
Tolerance	PWM 0002		+/- 20,0 %	+/- 20,0 %	+/- 20,0 %
Current consumption	$\Delta p = 0$	I	45 mA	40 mA	35 mA
Tolerance	PWM 0002		+/- 20,0 %	+/- 20,0 %	+/- 20,0 %
Speed	$\Delta p = 0$	n	1.000 1/min	1.000 1/min	1.000 1/min
Tolerance	PWM 0002		+/- 10 %	+/- 10,0 %	+/- 10,0 %

3.3 Operating Data - Electrical Interface -Output

Tacho type	/2 (Open collector)
------------	---------------------

Signal-Ausgangsspannung / Signal output voltage

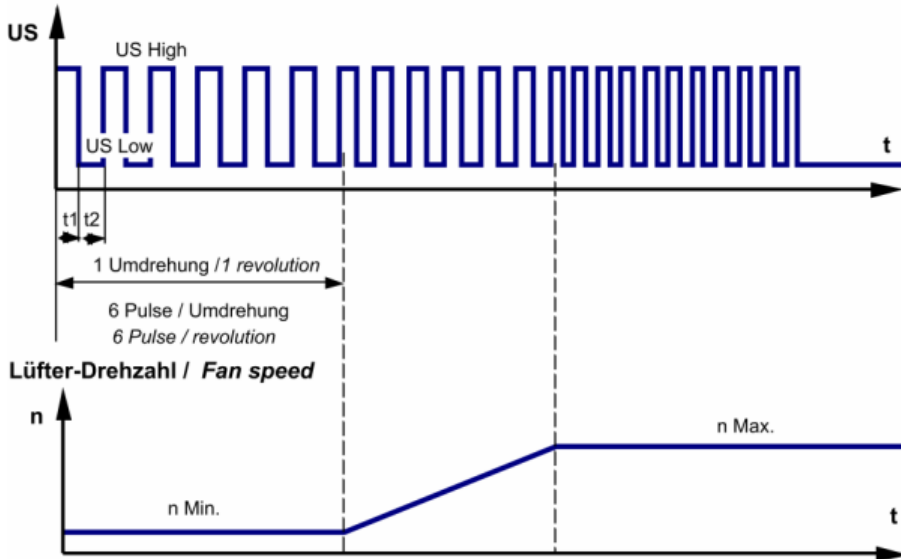

$$R_a = \frac{U_{BS} - U_{S\ Low}}{I_{Sink}}$$

Features	Note	Values
Tacho operating voltage (UBS)		<= 60,0 V
Tacho signal Low	I sink: 2 mA	<= 0,4 V
Tacho signal High	I source: 0 mA	60,0 V
Maximum sink current		<= 20 mA
External resistor	External resistor Ra from UBS to US required. All voltages measured to GND.	
Tacho frequency	(6 x n) / 60	
Tacho isolated from motor	No	
Slew rate		=> 0,5 V/us

Please note:

At zero speed the tacho signal is at a static HIGH. It will be also HIGH when the fan is still spinning, but the speed control signal is set to zero speed already.

The tacho signal is only activated after the start-up is completed.

Alarm type	None
------------	------

3.4 Electrical Features

Electronic function	Speed-Controlled	
Reversed polarity protection	P-CH FET	
Max. residual current at Un	IF ≤ 100 uA	
Locked rotor protection	Auto restart	
Locked rotor current at Un		
Clock signal t3/t4 at locked rotor	Typical: 2,5 s / 10,0 s	
	t4: 9,5 s... 10,5 s	

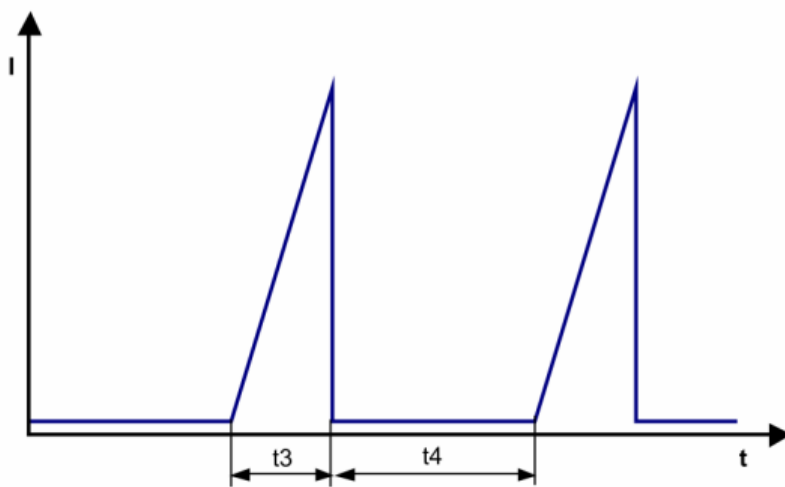

First locked rotor off time is reduced to 3 seconds.
 After 4 unsuccessful start up tries the fan will be turned off for 40 seconds. .

This fan has a startup delay of 2 seconds after applying supply voltage.

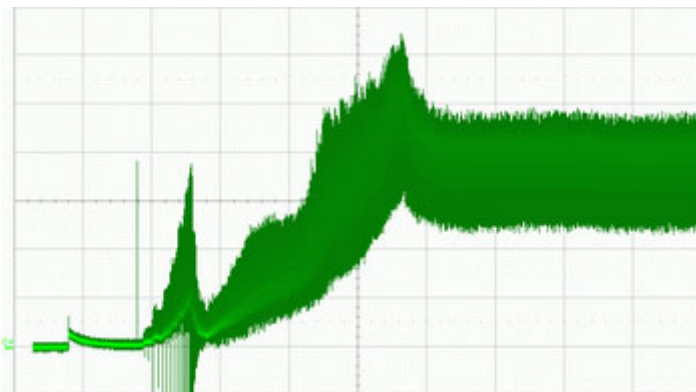

Start-up current @ 48 V (I = 200mA/div ; t = 2s/div)

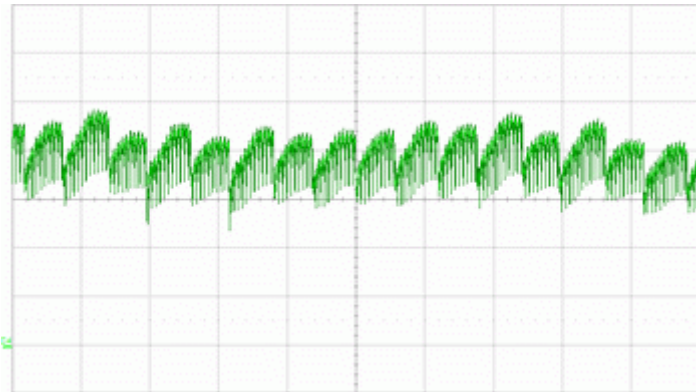

Running current @ 48 V (I = 200mA/div ; t = 1ms/div)

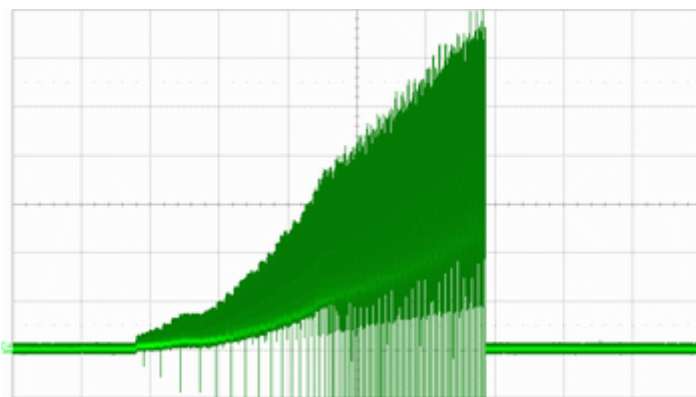

Locked rotor current @ 48 V (I = 200mA/div ; t = 500ms/div)

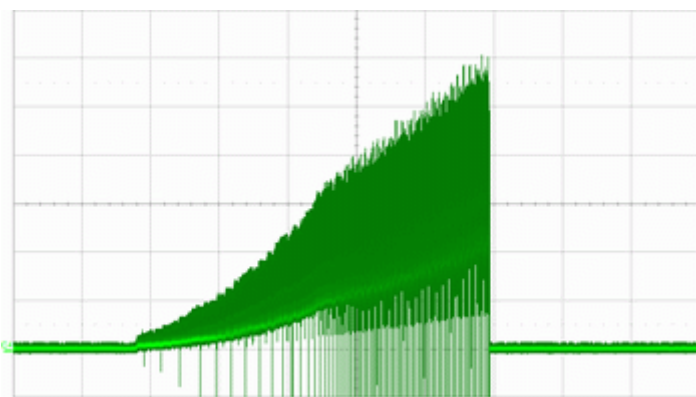

Locked rotor current @ 36 V (I = 200mA/div ; t = 500ms/div)

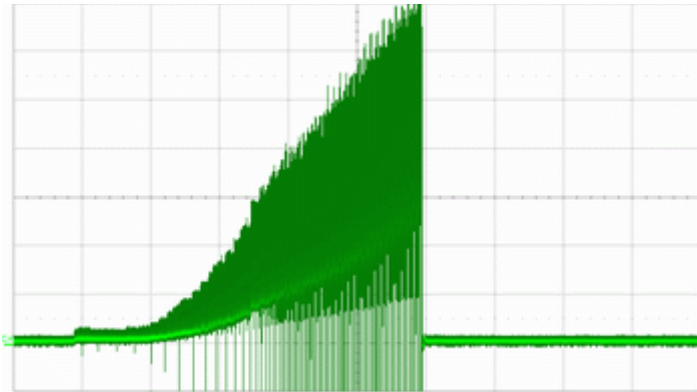

Locked rotor current @ 72 V (I = 200mA/div ; t = 500ms/div)

Internal Fuse:

Littelfuse Nano2 Fuse
Very Fast-Acting 451/453 Series
4A / 125V

3.5 Aerodynamic

Measurement conditions: Measured with a double chamber intake rig acc. to DIN EN ISO 5801.
 Normal air density = 1,2 kg/m³; Temperature 23°C +/- 3°C;
 In the intake and outlet area should not be any solid obstruction within 0,5 m.
 The information is only valid under the specified test conditions and may be changed by the installation conditions. If there are deviations from the standard test conditions, the characteristic values must be checked under the installed conditions.

a.) Operation condition:

5.500 1/min at free air flow	PWM 95 %; f: 2 kHz		
Max. free-air flow ($\Delta p = 0 / \dot{V} = \text{max.}$)		600,0 m ³ /h	
Max. static pressure ($\Delta p = \text{max.} / \dot{V} = 0$)		655 Pa	

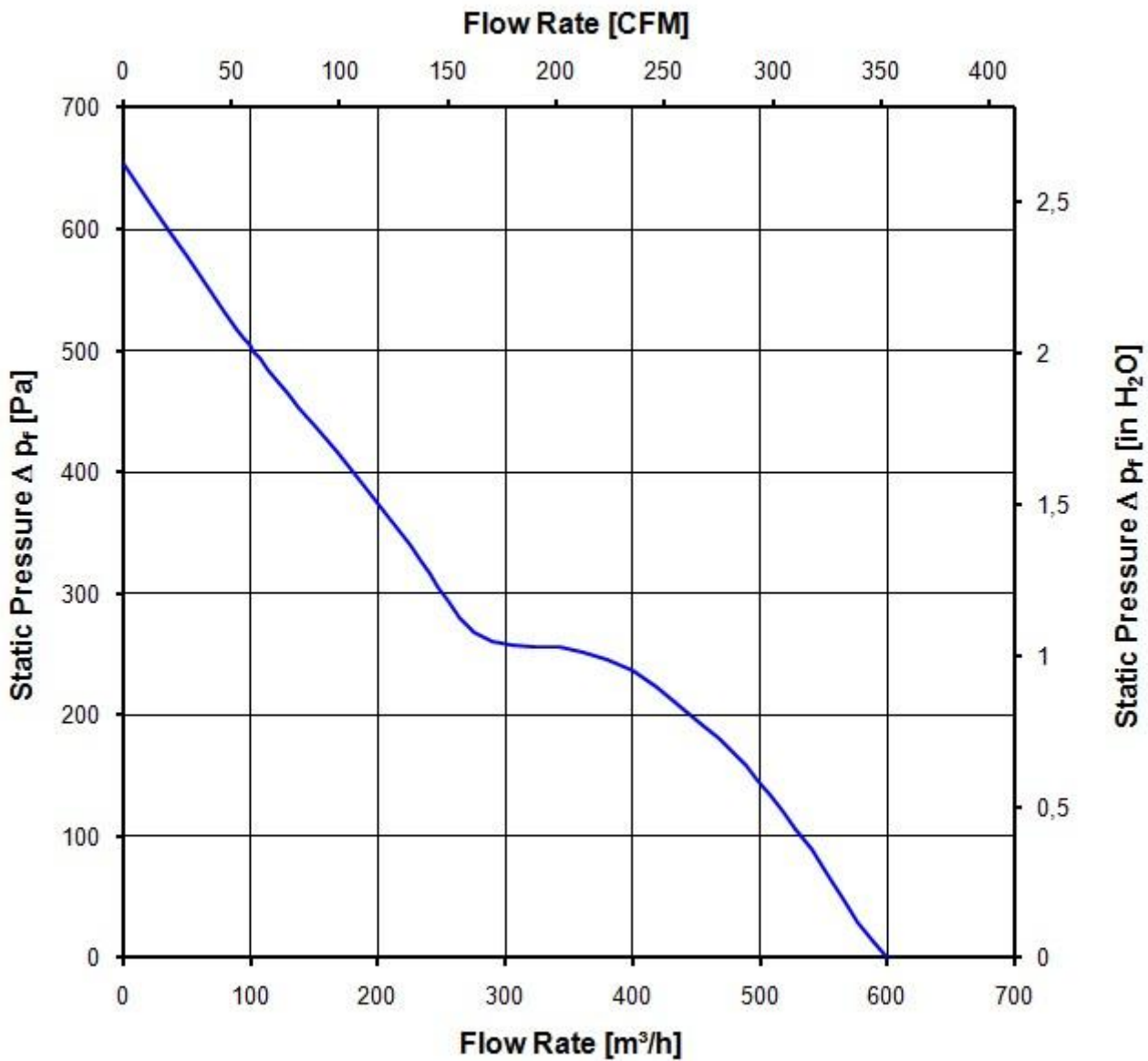

3.6 Sound Data

Measurement conditions: Sound pressure level: 1 Meter distance between microphone and the air intake.
 Sound power level: Acc. to DIN 45635 part 38 (ISO 10302)
 Measured in a semianchoic chamber with a background noise level of $L_p(A) < 5 \text{ dB(A)}$
 For further measurement conditions see section 3.5

a.) Operation condition:

5.500 1/min at free air flow	PWM 95 %; f: 2 kHz	PWM min.:	PWM max.:
------------------------------	--------------------	-----------	-----------

Optimal operating point	505,0 m3/h @ 123 Pa	
Sound power level at the optimal operating point	7,2 bel(A)	
Sound pressure level at free air flow, measured in rubber bands	63,0 dB(A)	

4 Environment

4.1 General

Min. permitted ambient temperature TU min.	-20 °C	
Max. permitted ambient temperature TU max.	75 °C	
Min. permitted storage temperature TL min.	-40 °C	
Max. permitted storage temperature TL max.	80 °C	

4.2 Climatic requirements *)

Humidity requirements	humid heat, constant; according to DIN EN 60068-2-78, 14 days	
Water exposure	None	
Dust requirements	None	
Salt fog requirements	None	

*) Permitted application area:

The product is intended for use in sheltered rooms with controlled temperature and controlled humidity. Directly exposure to water must be avoided.

Pollution degree 1 (according DIN EN 60664-1)

There is either no pollution or it occurs only dry, non-conductive pollution. The pollution has no negative impact.

5 Safety

5.1 Electrical Safety

Dielectric strength DIN EN 60950 (VDE 0805) and DIN EN 60335 (VDE 0700) A.) Type test Measuring conditions: After 48h of storage at 95% R.H. and 25°C. No arcing or breakdown is allowed! All connections together to ground. B.) Routine test Measuring conditions: At indoor climate. No arcing or breakdown is allowed! All connections together to ground.	1000 VAC / 1 Min. 1000 VAC / 1 Sec.	
Isolation resistance Measuring conditions: After 48h of storage at 95% R.H. and 25°C measured with U=500 VDC for 1 min.	RI > 10 MOhm	
clearance / creepage distance	1,0 mm / 1,5 mm	
Protection class	I	

5.2 Approval Tests

CE	EC Declaration of Conformity	Yes
EAC	Eurasian Conformity	Yes
UL	Underwriters Laboratories	Yes / UL audited by CSA according to UL507, Electric Fans
VDE	Association for Electrical, Electronic and Information Technologies	Yes / Approval acc. to EN 60950 (VDE 0805) - Information technology equipment
CSA	Canadian Standards Association	Yes / C22.2 No. 113 Fans and Ventilators
CCC	China Compulsory Certification	Yes / GB 12350 Safety Requirements for small Power Motors

The approval tests are observed to:

U approval max.: 72,0 V @ TU approval max.: 70,0 °C

6 Reliability

6.1 General

Life expectancy L10 at TU = 40 °C	75.000 h	
Life expectancy L10 at TU max.	30.000 h	
Life expectancy L10 IPC (40 °C)	127.500 h	

Kopie der Zeichnung und/oder Zeichnung ist ohne Verantwortung der ebmpapst AG.
 Kopie der Zeichnung und/oder Zeichnung ist ohne Verantwortung der ebmpapst AG.
 In the event of the need for a copy of the reproduction of technical drawings, please contact:

Maßstab nach DIN ISO 5454 (1:1)
 Maßstab nach DIN ISO 5454 (1:1)

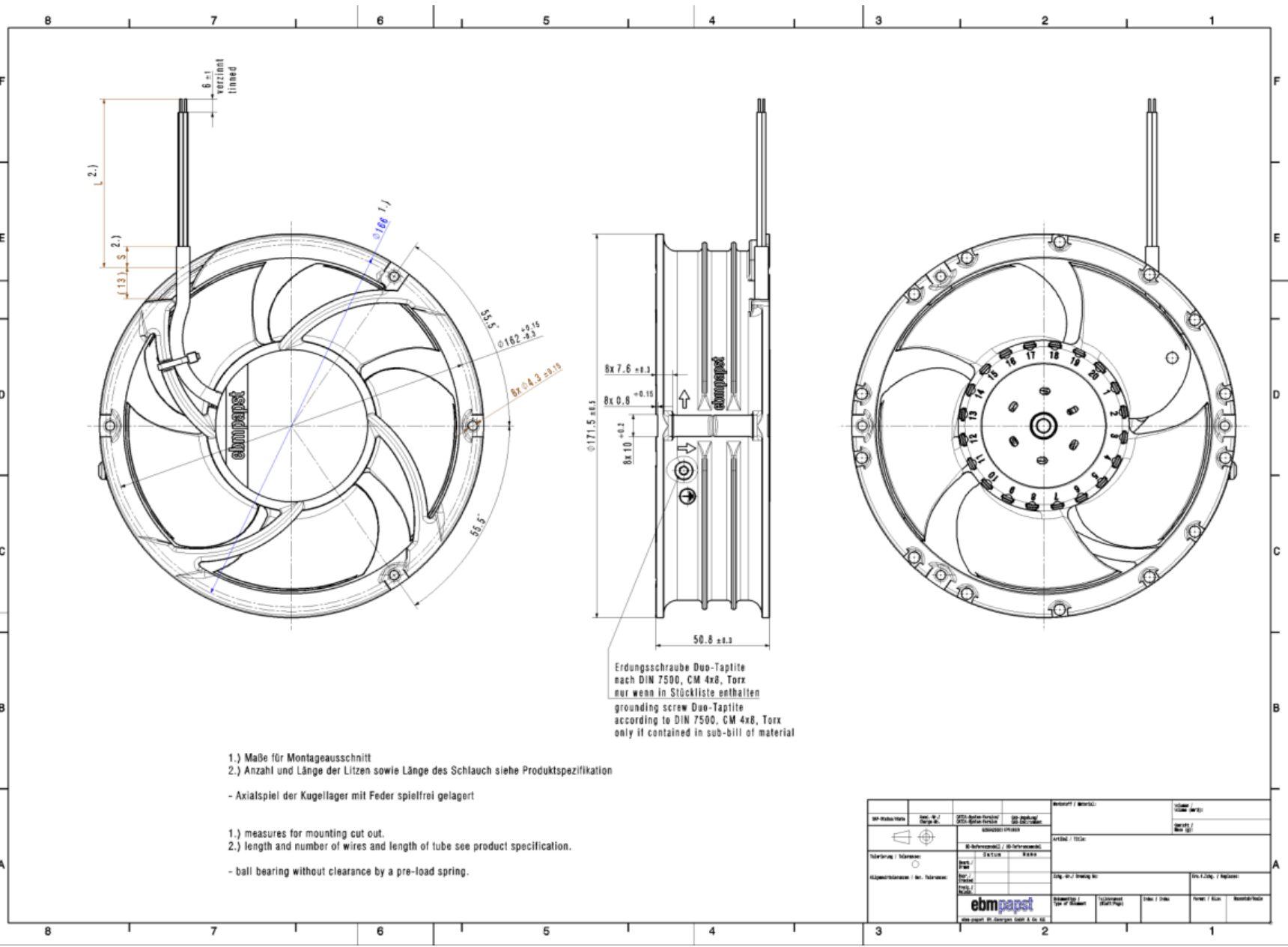

Erdungsschraube Duo-Tapfite
 nach DIN 7500, CM 4x8, Torx
 nur wenn in Stückliste enthalten
 grounding screw Duo-Tapfite
 according to DIN 7500, CM 4x8, Torx
 only if contained in sub-bill of material

- 1.) Maße für Montageausschnitt
 2.) Anzahl und Länge der Litzen sowie Länge des Schlauch siehe Produktspezifikation
 - Axialspiel der Kugellager mit Feder spielfrei gelagert
 1.) measures for mounting cut out.
 2.) length and number of wires and length of tube see product specification.
 - ball bearing without clearance by a pre-load spring.

ebmpapst ebmpapst AG 48073 Garscham Germany	2025-01-01 2025-01-01 2025-01-01	2025-01-01 2025-01-01 2025-01-01	2025-01-01 2025-01-01 2025-01-01	2025-01-01 2025-01-01 2025-01-01	2025-01-01 2025-01-01 2025-01-01
--	--	--	--	--	--