

Product Data Sheet 4184 NXHH

ebmpapst

Die Wahl der Ingenieure



4184 NXHH

INDEX

1 General 3

2 Mechanics 3

 2.1 General 3

 2.2 Connections 3

3 Operating Data 3

 3.1 Operating Data - Electrical Interface - Input 3

 3.2 Electrical Operating Data 4

 3.3 Operating Data - Electrical Interface -Output 4

 3.4 Electrical Features 4

 3.5 Aerodynamic 5

 3.6 Sound Data 6

4 Environment 6

 4.1 General 6

 4.2 Climatic requirements*) 6

5 Safety 7

 5.1 Electrical Safety 7

 5.2 Approval Tests 7

6 Reliability 7

 6.1 General 7

1 General

Fan type	Fan	
Rotational direction looking at rotor	clockwise	
Airflow direction	Air intake over struts	
Bearing system	Ball bearing	
Mounting position	any	

2 Mechanics

2.1 General

Width	119,0 mm	
Height	119,0 mm	
Depth	38,0 mm	
Weight	0,380 kg	
Housing material	Metal	
Impeller material	Plastic	
Max. torque when mounted across both mounting flanges	wire outlet corner: 170 Ncm remaining corners: 300 Ncm	
Screw size	ISO 4762 - M3 degreased, without an additional brace and without washer	

2.2 Connections

Electrical connection	Plug	
Length of lead wire		
Tolerance		
Wire gauge (AWG)		
Insulation diameter		
Contact	see drawing	

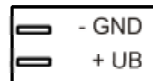

3 Operating Data

3.1 Operating Data - Electrical Interface - Input

Control input	None
---------------	------

3.2 Electrical Operating Data

Measurement conditions: Normal air density = 1,2 kg/m³; Temperature 23°C +/- 3°C; Motor axis horizontal; warm-up time before measuring 5 minutes (unless otherwise specified). In the intake and outlet area should not be any solid obstruction within 0,5 m.

$\Delta p = 0$: corresp. to free air flow (see section 3.5)
 I: corresp. to arithm. mean current value

Features	Condition	Symbol	Values		
Voltage range	$\Delta p = 0$	U	12,0 V		25,0 V
Nominal voltage	$\Delta p = 0$	U_N		24,0 V	
Power consumption	$\Delta p = 0$	P	2,9 W	13,6 W	14,8 W
Tolerance	0001		+/- 17,5 %	+/- 12,5 %	+/- 15,0 %
Current consumption	$\Delta p = 0$	I	240 mA	570 mA	590 mA
Tolerance	0001		+/- 17,5 %	+/- 12,5 %	+/- 15,0 %
Speed	$\Delta p = 0$	n	2.800 1/min	4.900 1/min	5.100 1/min
Tolerance	0001		+/- 12,5 %	+/- 7,5 %	+/- 10,0 %
Starting current consumption				2.870 mA	

3.3 Operating Data - Electrical Interface -Output

Tacho type	None
------------	------

Alarm type	None
------------	------

3.4 Electrical Features

Electronic function	None	
Reversed polarity protection	Rectifying diode	
Max. residual current at U_N	$I_F \leq 20 \mu A$	
Locked rotor protection	Auto restart	
Locked rotor current at U_N	approx. 2.870 mA	
Clock signal t_3/t_4 at locked rotor	Typical: 0,3 s / 1,6 s	

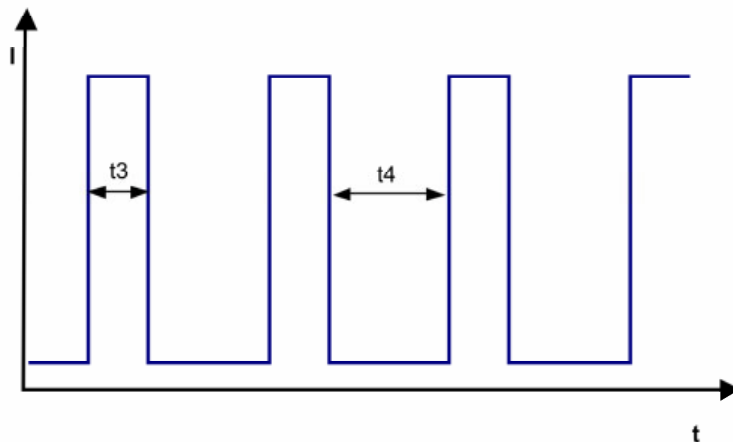

3.5 Aerodynamic

Measurement conditions: Measured with a double chamber intake rig acc. to DIN EN ISO 5801.
 Normal air density = 1,2 kg/m³; Temperature 23°C +/- 3°C;
 In the intake and outlet area should not be any solid obstruction within 0,5 m.
 The information is only valid under the specified test conditions and may be changed by the installation conditions. If there are deviations from the standard test conditions, the characteristic values must be checked under the installed conditions.

a.) Operation condition:

4.900 1/min at free air flow

Max. free-air flow ($\Delta p = 0 / \dot{V} = \text{max.}$)	260,0 m ³ /h	
Max. static pressure ($\Delta p = \text{max.} / \dot{V} = 0$)	204 Pa	

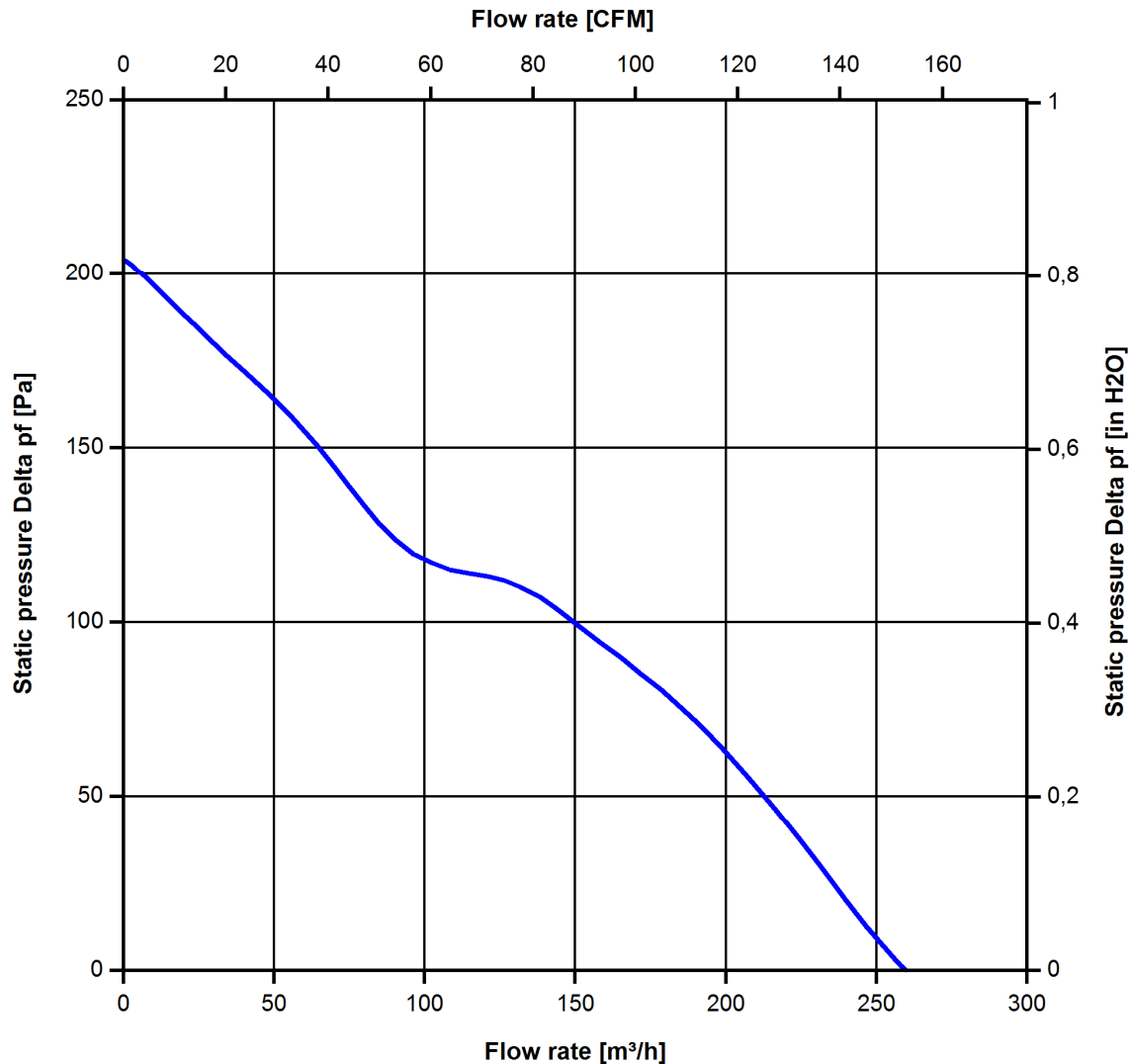

3.6 Sound Data

Measurement conditions: Sound pressure level: 1 Meter distance between microphone and the air intake.
 Sound power level: Acc. to DIN 45635 part 38 (ISO 10302)
 Measured in a semianchoic chamber with a background noise level of $L_p(A) < 5 \text{ dB(A)}$
 For further measurement conditions see section 3.5

a.) Operation condition:

4.900 1/min at free air flow

Optimal operating point	160,0 m ³ /h @ 100 Pa	
Sound power level at the optimal operating point	6,7 bel(A)	
Sound pressure level at free air flow, measured in rubber bands	60,0 dB(A)	

4 Environment

4.1 General

Min. permitted ambient temperature TU min.	-30 °C	
Max. permitted ambient temperature TU max.	55 °C	
Min. permitted storage temperature TL min.	-40 °C	
Max. permitted storage temperature TL max.	80 °C	

4.2 Climatic requirements *)

Humidity requirements	humid heat, constant; according to DIN EN 60068-2-78, 14 days	
Water exposure	None	
Dust requirements	None	
Salt fog requirements	None	

*) Permitted application area:

The product is intended for use in sheltered rooms with controlled temperature and controlled humidity. Directly exposure to water must be avoided.

Pollution degree 1 (according DIN EN 60664-1)

There is either no pollution or it occurs only dry, non-conductive pollution. The pollution has no negative impact.

Please require severity levels and specification parameters from the responsible development departments

5 Safety

5.1 Electrical Safety

Dielectric strength DIN EN 60950 (VDE 0805) and DIN EN 60335 (VDE 0700) A.) Type test Measuring conditions: After 48h of storage at 95% R.H. and 25°C. No arcing or breakdown is allowed! All connections together to ground.	500 VAC / 1 Min.	
B.) Routine test Measuring conditions: At indoor climate. No arcing or breakdown is allowed! All connections together to ground.	500 VAC / 1 Sec.	
Isolation resistance Measuring conditions: After 48h of storage at 95% R.H. and 25°C measured with U=500 VDC for 1 min.	RI > 10 MOhm	
clearance / creepage distance	1,0 mm / 1,2 mm	
Protection class	III	

5.2 Approval Tests

CE	EC Declaration of Conformity	Yes
EAC	Eurasian Conformity	Yes
UL	Underwriters Laboratories	Yes / UL507, Electric Fans
VDE	Association for Electrical, Electronic and Information Technologies	Yes / Approval acc. to EN 60950 (VDE 0805) - Information technology equipment
CSA	Canadian Standards Association	Yes / C22.2 No. 113 Fans and Ventilators
CCC	China Compulsory Certification	No

The approval tests are observed to:

U approval max.:25,0 V @ TU approval max.: 55,0 °C

6 Reliability

6.1 General

Life expectancy L10 at TU = 40 °C	70.000 h	
Life expectancy L10 at TU max.	52.500 h	

Copying of this document and using it is others and the use or reproduction of its contents, in whole or in part, is prohibited. Offenders shall be liable for the payment of damages. All rights are reserved in the event of the grant of a patent or the registration of a utility model or design.

Schulzwerkstatt nach DIN ISO 10000 beachten/
Refer to production notice DIN ISO 10000!

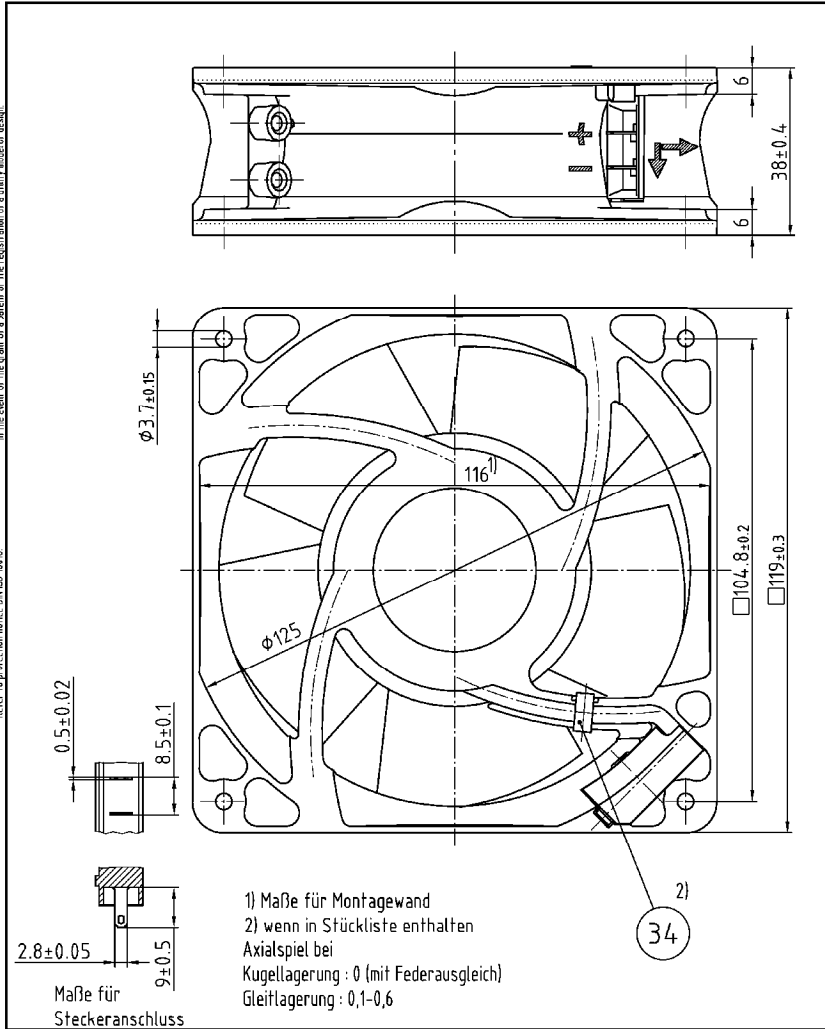

Tolerierung/Tolerances: DIN 7167			
Allgemein/ toleranzen/ Gen. tolerances:			
	Datum/Date	Artikel/Title	Maßstab/Scale
Bearb./Drawn:	Name/Name		
	Index/Index	Zchg.-Nr./ Dwg.-No.:	Blatt/Page
	Änd.-Nr./Change-No.		
gep. u. zur Verwendung freigegeben/Checked for release van am by on		ebmpapst ebm-papst St. Georgen GmbH & Co. KG	Frs f. Zchg./ Replaces: A4