



The engineer's choice

**ebmpapst**

6318/2TDH4P-007

## INDEX

<b>1</b>	<b>General</b> .....	<b>3</b>
<b>2</b>	<b>Mechanics</b> .....	<b>3</b>
2.1	General.....	3
2.2	Connections.....	3
<b>3</b>	<b>Operating Data</b> .....	<b>4</b>
3.1	Operating Data - Electrical Interface - Input.....	4
3.2	Electrical Operating Data .....	5
3.3	Operating Data - Electrical Interface -Output .....	6
3.4	Electrical Features.....	7
3.5	Data according ErP directive.....	9
3.6	Aerodynamic.....	9
3.7	Sound Data.....	10
<b>4</b>	<b>Environment</b> .....	<b>11</b>
4.1	General.....	11
4.2	Climatic requirements*) .....	11
<b>5</b>	<b>Safety</b> .....	<b>12</b>
5.1	Electrical Safety.....	12
5.2	Approval Tests .....	12
<b>6</b>	<b>Reliability</b> .....	<b>12</b>
6.1	General.....	12

## 1 General

Fan type	Fan	
Rotational direction looking at rotor	counterclockwise	
Airflow direction	Air outlet over struts	
Bearing system	Ball bearing	
Mounting position	any	

## 2 Mechanics

### 2.1 General

Width	160,0 mm	
Depth	51,0 mm	
Diameter	172,0 mm	
Weight	0,875 kg	
Housing material	Metal	
Impeller material	Plastic	
Max. torque when mounted across both mounting flanges	wire outlet corner: 600 Ncm remaining corners: 600 Ncm	
Screw size	ISO 4762 - M4 degreased, without an additional brace and without washer	

### 2.2 Connections

Electrical connection	Wires	
Length of lead wire	L = 365 mm	
Tolerance	+/- 10,0 mm	
Length of tube	S = 10 mm	
Tolerance	+/- 2,0 mm	
Wire gauge (AWG)	18 22	
Insulation diameter	1,7 mm 2,2 mm	
Contact	see drawing	

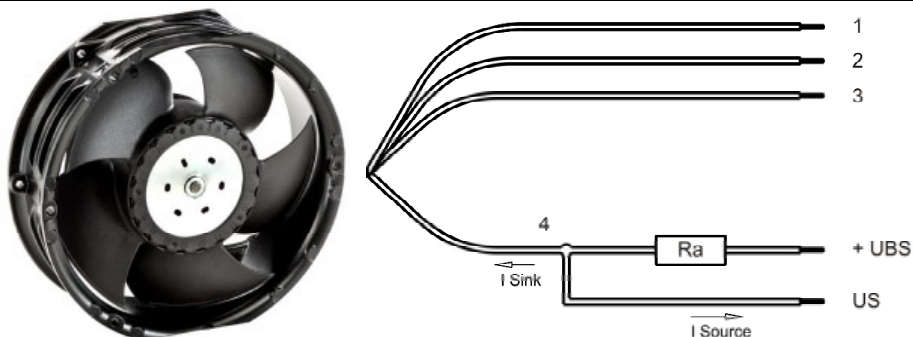

	Colour	Operation
Wire 1	red	+ UB
Wire 2	blue	- GND
Wire 3	violet	PWM
Wire 4	white	Tacho

The auxiliaries shown on the schematic diagram (which are required for the intended use) are not part of our delivery.

Lead wire 1 - 2: AWG18 (Insulation diameter 2,20 mm)

Lead wire 3 - 4: AWG22 (Insulation diameter 1,70 mm)

### 3 Operating Data

#### 3.1 Operating Data - Electrical Interface - Input

Control input	PWM
---------------	-----

#### Features

Input type	Open collector	
PWM - Frequency		1 kHz - 20 kHz Typical: 2 kHz

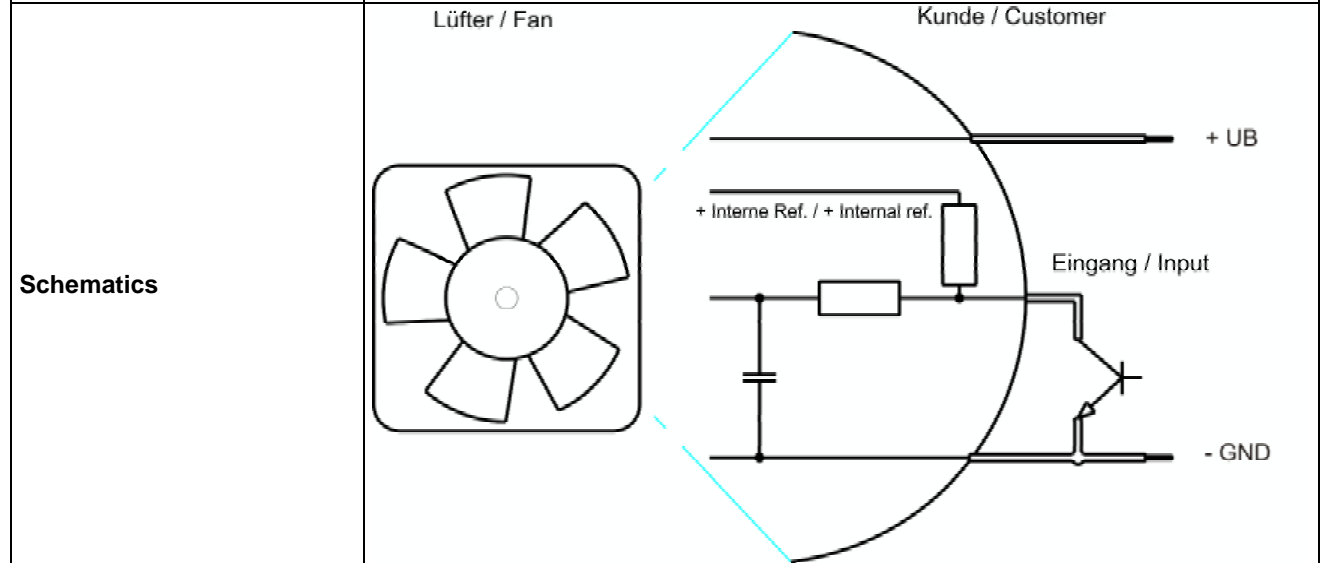
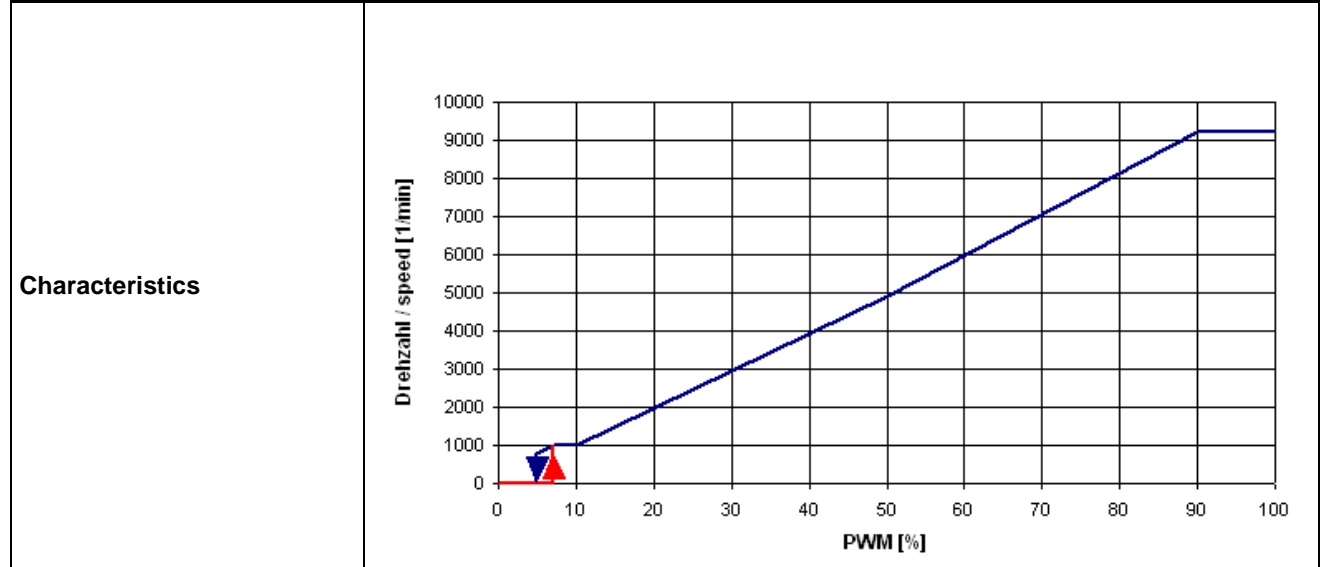

The shown pull-up resistor to the internal reference voltage (+5V) has 4.7kOhm.

**Information to the curve:**

0% - <=7% PWM: 0 1/min (Fan off) 1.000 1/min (Start-up, comming from 0% PWM)  
 7% PWM: 1.000 1/min (corresp. to min fan speed)  
 7% - 10 % PWM: Linear increasing curve  
 10% - 90% PWM: 9.200 1/min (corresp. to max fan speed)  
 90% - 100% PWM: 800 1/min or 0 1/min (Fan turns off, comming from 5% PWM)  
 5% PWM: 100% PWM)

**Transistor Requirements:**

VCE max. >= 12V  
 Isink max > 5mA  
 VCEsat < 0,15V

**3.2 Electrical Operating Data**

Measurement conditions: Normal air density = 1,2 kg/m<sup>3</sup>; Temperature 23°C +/- 3°C; Motor axis horizontal; warm-up time before measuring 5 minutes (unless otherwise specified). In the intake and outlet area should not be any solid obstruction within 0,5 m.

$\Delta p = 0$ : corresp. to free air flow (see section 3.5)  
 I: corresp. to arithm. mean current value

Name	Condition
PWM 0001	PWM: 95 %; f: 2 kHz

Features	Condition	Symbol	Values		
Voltage range	$\Delta p = 0$	U	36,0 V		72,0 V
Nominal voltage	$\Delta p = 0$	$U_N$		48,0 V	
Power consumption	$\Delta p = 0$	P	115,0 W	150,0 W	160,0 W
Tolerance	PWM 0001		+/- 10,0 %	+/- 10,0 %	+/- 10,0 %
Current consumption	$\Delta p = 0$	I	3.200 mA	3.100 mA	2.200 mA
Tolerance	PWM 0001		+/- 10,0 %	+/- 10,0 %	+/- 10,0 %
Speed	$\Delta p = 0$	n	8.500 1/min	9.200 1/min	9.200 1/min
Tolerance	PWM 0001		+/- 7,5 %	+/- 5,0 %	+/- 5,0 %

**>90% PWM; f = 2 kHz or broken lead wire (open control input)**

Built into the fan is an additional under- and overvoltage control, which switches the power stage and the fan off if the following conditions are reached.

At  $U \leq 30 V$  and / or  $U \geq 78 V$  is  $n = 0$  1/min

Optionally tests operate at  $U \leq 30 VDC$  only.

**Measured values at 24°C:**

$U_{ON} = 32 V$ ;  $U_{OFF} = 29,5 V$   
 $U_{ON} = 75,5 V$ ;  $U_{OFF} = 77,5 V$

The values depends on temperature and fan speed, i. e. they may differ minimal and provide a basis.

Name	Condition
PWM 0002	PWM: 50 %; f: 2 kHz

Features	Condition	Symbol	Values		
Voltage range	$\Delta p = 0$	U	36,0 V		72,0 V
Nominal voltage	$\Delta p = 0$	$U_N$		48,0 V	
Power consumption	$\Delta p = 0$	P	28,5 W	29,5 W	32,5 W
Tolerance	PWM 0002		+/- 10,0 %	+/- 10,0 %	+/- 10,0 %
Current consumption	$\Delta p = 0$	I	800 mA	615 mA	450 mA
Tolerance	PWM 0002		+/- 10,0 %	+/- 10,0 %	+/- 10,0 %
Speed	$\Delta p = 0$	n	5.000 1/min	5.000 1/min	5.000 1/min
Tolerance	PWM 0002		+/- 10,0 %	+/- 10,0 %	+/- 10,0 %

### 3.3 Operating Data - Electrical Interface -Output

Tacho type	/2 (Open collector)
------------	---------------------

Signal-Ausgangsspannung / Signal output voltage

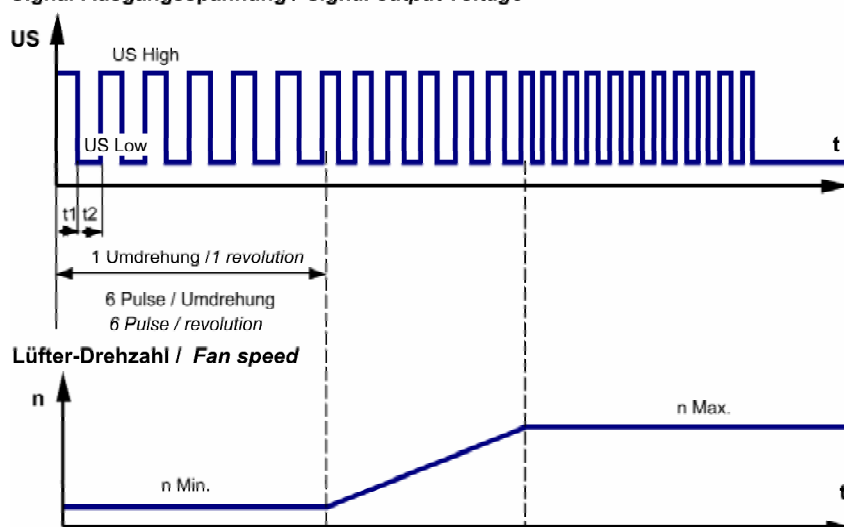

$$R_a = \frac{U_{BS} - U_{S\ Low}}{I_{Sink}}$$

Features	Note	Values
Tacho operating voltage (UBS)		$\leq 60\ V$
Tacho signal Low	I sink: 2 mA	$\leq 0,4\ V$
Tacho signal High	I source: 0 mA	60,0 V
Maximum sink current		$\leq 20\ mA$
External resistor	External resistor $R_a$ from UBS to US required. All voltages measured to GND.	
Tacho frequency	$(6 \times n) / 60$	
Tacho isolated from motor	No	
Slew rate		$\Rightarrow 0,5\ V/\mu s$

Alarm type	None
------------	------

### 3.4 Electrical Features

Electronic function	Speed-Controlled	
Reversed polarity protection	P-CH FET	
Max. residual current at $U_n$	$I_F \leq 5 \text{ mA}$	
Locked rotor protection	Auto restart	
Locked rotor current at $U_n$		
Clock signal $t3/t4$ at locked rotor	Typical: 1,5 s / 10,0 s	

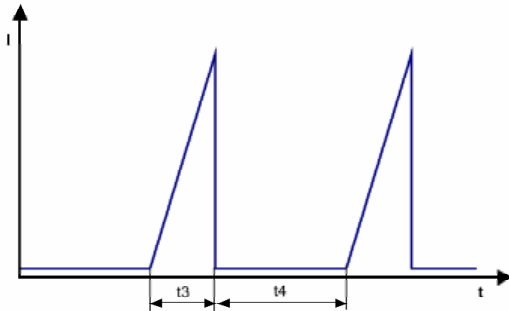

First locked rotor off time is reduced to 3 seconds.

This fan has a startup delay of 2 seconds after applying supply voltage.

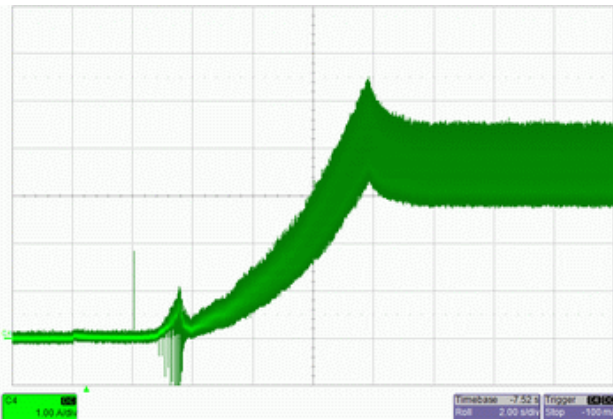

Start-up current @ 48 V ( $I = 1 \text{ A/div}$  ;  $t = 2 \text{ s/div}$ )

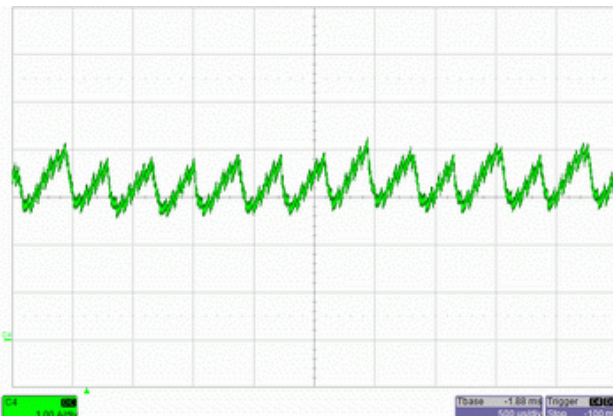

Running current @ 48 V ( $I = 1 \text{ A/div}$  ;  $t = 500 \mu\text{s/div}$ )

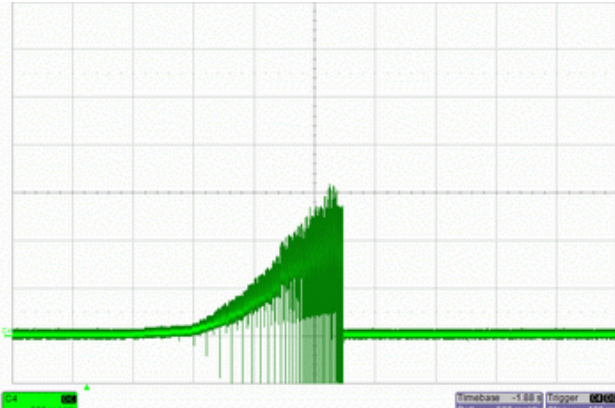

Locked rotor current @ 48 V (I = 500mA/div ; t = 500ms/div)

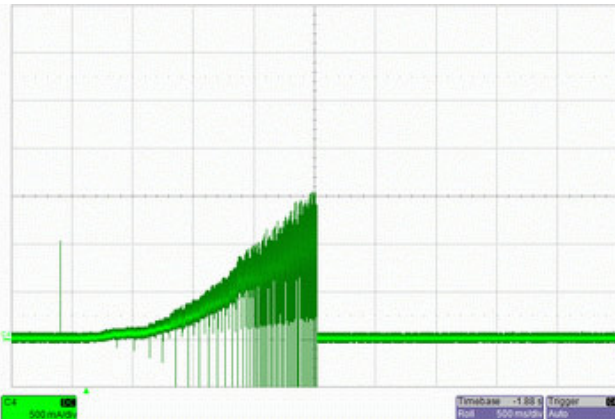

Locked rotor current @ 36 V (I = 500mA/div ; t = 500ms/div)

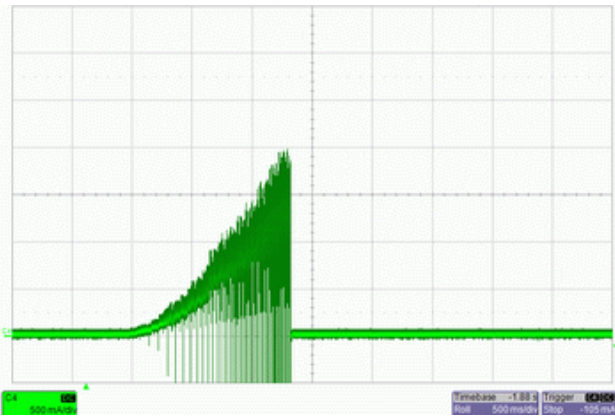

Locked rotor current @ 72 V (I = 500mA/div ; t = 500ms/div)

**Internal Fuse:**

Littelfuse Nano2 Fuse  
Very Fast-Acting 451/453 Series  
10A / 125V



**3.5 Data according ErP directive**

Installation / Efficiency category	A / static
Speed control	integrated
Specific ratio	1,00569
Target overall efficiency 2015	29,8 %
Overall efficiency	42,9 %
Efficiency grade	40
Power input	245 W
Speed	9.360 1/min

All values measured in optimum energy efficiency point.

Productiondatecode is printed on the fan label.

**3.6 Aerodynamic**

Measurement conditions: Measured with a double chamber intake rig acc. to DIN EN ISO 5801.  
 Normal air density = 1,2 kg/m<sup>3</sup>; Temperature 23°C +/- 3°C;  
 In the intake and outlet area should not be any solid obstruction within 0,5 m.  
 The information is only valid under the specified test conditions and may be changed by the installation conditions. If there are deviations from the standard test conditions, the characteristic values must be checked under the installed conditions.

a.) Operation condition:

9.200 1/min at free air flow	PWM 95 %; f: 2 kHz		
------------------------------	--------------------	--	--

Max. free-air flow ( $\Delta p = 0 / \dot{V} = \text{max.}$ )	930,0 m <sup>3</sup> /h	
Max. static pressure ( $\Delta p = \text{max.} / \dot{V} = 0$ )	1.310 Pa	

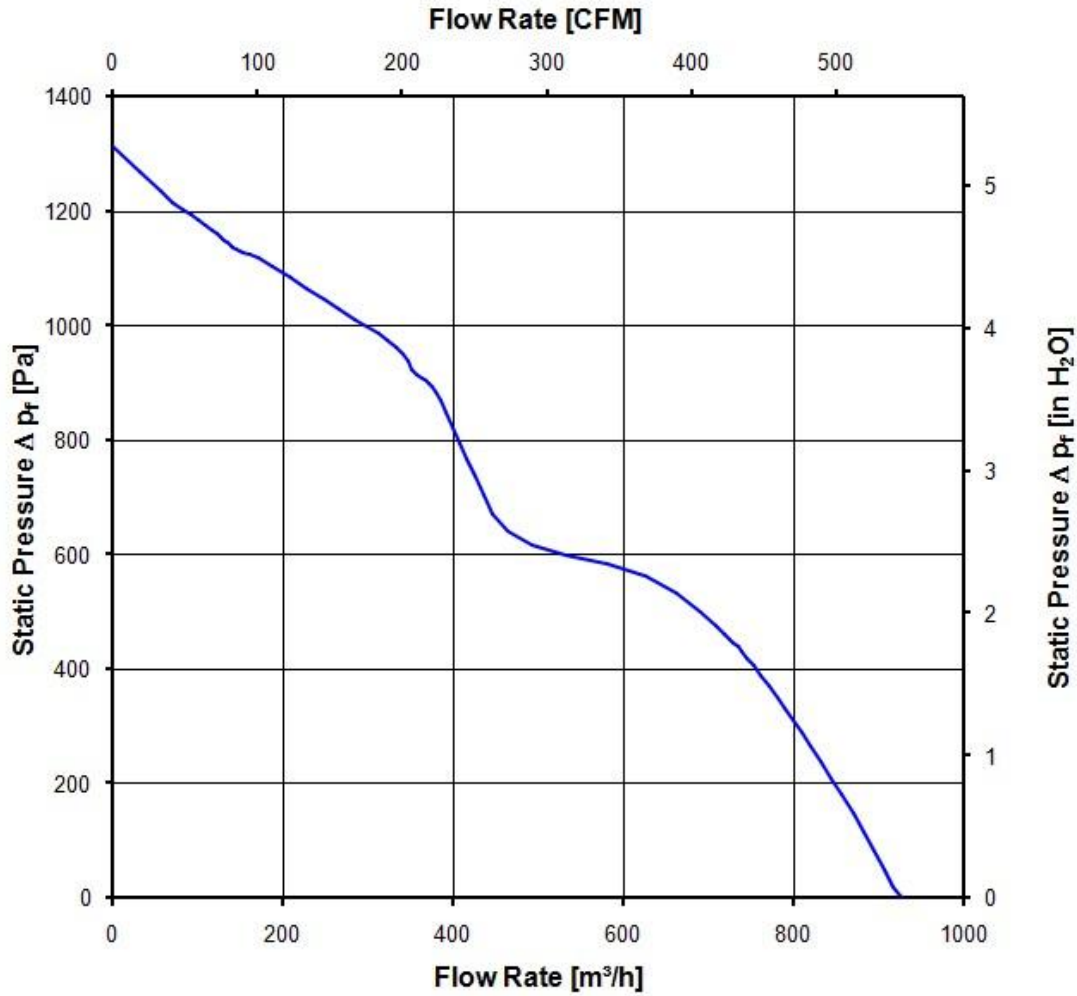

### 3.7 Sound Data

Measurement conditions: Sound pressure level: 1 Meter distance between microphone and the air intake.  
 Sound power level: Acc. to DIN 45635 part 38 (ISO 10302)  
 Measured in a semianchoic chamber with a background noise level of  $L_p(A) < 5 \text{ dB(A)}$   
 For further measurement conditions see section 3.5

a.) Operation condition:

9.200 1/min at free air flow	PWM 95 %; f: 2 kHz	PWM min.:	PWM max.:
------------------------------	--------------------	-----------	-----------

Optimal operating point	910,0 m <sup>3</sup> /h @ 34 Pa	
Sound power level at the optimal operating point	8,6 bel(A)	
Sound pressure level at free air flow, measured in rubber bands	75,0 dB(A)	

## 4 Environment

### 4.1 General

Min. permitted ambient temperature TU min.	-20 °C	
Max. permitted ambient temperature TU max.	75 °C	
Min. permitted storage temperature TL min.	-40 °C	
Max. permitted storage temperature TL max.	80 °C	

### 4.2 Climatic requirements \*)

Humidity requirements	humid heat, constant; according to DIN EN 60068-2-78, 14 days	
Water exposure	None	
Dust requirements	None	
Salt fog requirements	None	

\*) Permitted application area:

The product is intended for use in sheltered rooms with controlled temperature and controlled humidity. Directly exposure to water must be avoided.

Pollution degree 1 (according DIN EN 60664-1)

There is either no pollution or it occurs only dry, non-conductive pollution. The pollution has no negative impact. Please require severity levels and specification parameters from the responsible development departments

## 5 Safety

### 5.1 Electrical Safety

Dielectric strength DIN EN 60950 (VDE 0805) and DIN EN 60335 (VDE 0700) A.) Type test Measuring conditions: After 48h of storage at 95% R.H. and 25°C. No arcing or breakdown is allowed! All connections together to ground.	1000 VAC / 1 Min.	
B.) Routine test Measuring conditions: At indoor climate. No arcing or breakdown is allowed! All connections together to ground.	1000 VAC / 1 Sec.	
Isolation resistance Measuring conditions: After 48h of storage at 95% R.H. and 25°C measured with U=500 VDC for 1 min.	RI > 10 MOhm	
clearance / creepage distance	1,0 mm / 1,5 mm	
Protection class	I	

### 5.2 Approval Tests

CE	No
UL	Yes / UL audited by CSA according to UL507, Electric Fans
VDE	Yes / Approval acc. to EN 60950 (VDE 0805) - Information technology equipment
CSA	Yes / C22.2 No. 113 Fans and Ventilators
CCC	Yes / GB 12350 Safety Requirements for small Power Motors

The approval tests are observed to:

U approval max.: 72,0 V @ TU approval max.: 75,0 °C

## 6 Reliability

### 6.1 General

Life expectancy L10 at TU = 40 °C	52.500 h	
Life expectancy L10 at TU max.	20.000 h	
Life expectancy L10 Delta (40 °C)	105.000 h	

Zeichnung nach DIN EN ISO 10303-21 (STEP) / Drawing according to DIN EN ISO 10303-21 (STEP)  
 Maßstab 1:1 / Scale 1:1  
 Maßstab 1:1 / Scale 1:1

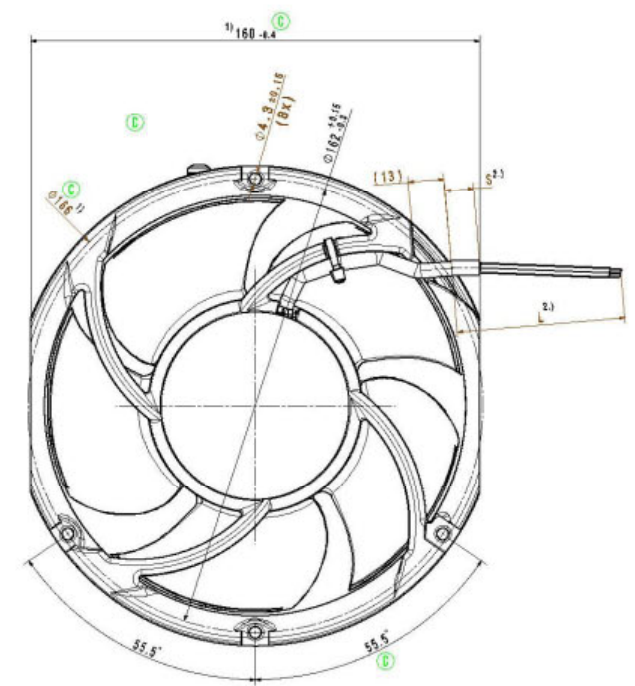
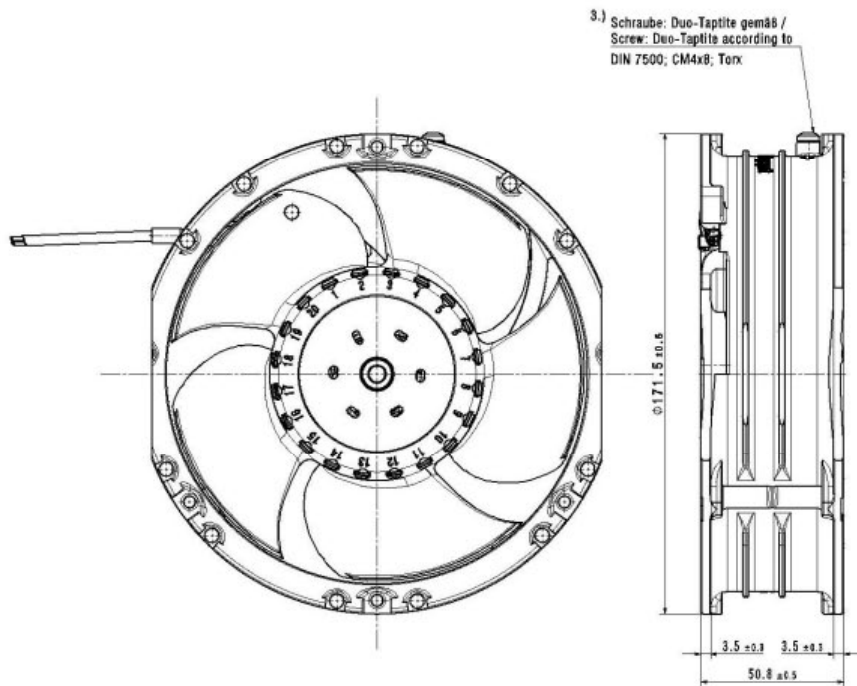

- C**
- 1.) Maße für Montageausschnitt. / Dimensions for assembly wall.
  - 2.) Anzahl und Länge von Litzen u. Schlauch siehe Produktspezifikation. / Length an number of wires and tube see product specification.
  - 3.) Nur wenn in Stückliste enthalten. / Only it is included in bill of material.
    - Axialspiel der Kugellager mit Feder spielfrei verspannt. / Ball bearing without clearance by a preload spring.

Zeichnung entspricht 3D-Modell:  
 Drawing is equivalent to 3D-Model:  
 6296420017\_CPR\_000\_-  
 System: CATIA V5 R 19

Material: 	Maßstab: Scale:	Geometrische Toleranzen: Geometric Tolerances:	Oberflächenbeschaffenheit: Surface Texture:	Material / Name: Material:	Zeichnung Nr.: Drawing No.:
Fertigung / Name: Manufacturing / Name:	Maßstab: Scale:	Maßstab: Scale:	Maßstab: Scale:	Anzahl / Stück: Quantity:	Datum / Datum: Date:
Fertigungsbereich / Im. Name: Manufacturing Area / Im. Name:	Geometrische Toleranzen: Geometric Tolerances:	Oberflächenbeschaffenheit: Surface Texture:	Oberflächenbeschaffenheit: Surface Texture:	Zeichnung Nr.: Drawing No.:	Datum / Datum: Date:
Zeichnung Nr.: Drawing No.:			Datum / Datum: Date:		
Zeichnung Nr.: Drawing No.:			Datum / Datum: Date:		

