

## ASIA PACIFIC SHENGRUI LIMITED

Phone +00852 56261528

info@apacshengrui.com

www.apacfan.com

## Nominal data

Type	W2E208-BA20-51		
Motor	M2E068-CF		
Phase		1~	1~
Nominal voltage	VAC	230	230
Frequency	Hz	50	60
Method of obtaining data		fa	fa
Valid for approval/standard		CE	CE
Speed (rpm)	min <sup>-1</sup>	2750	3100
Power consumption	W	67	87
Current draw	A	0.33	0.39
Capacitor	μF	1.5	1.5
Capacitor voltage	VDB	400	400
Capacitor standard		S0 (CE)	S0 (CE)
Min. back pressure	Pa	0	0
Max. back pressure	Pa	135	165
Min. back pressure	inH <sub>2</sub> O	0	0
Max. back pressure	inH <sub>2</sub> O	0.54	0.66
Min. ambient temperature	°C	-25	-25
Max. ambient temperature	°C	72	72
Starting current	A	0.92	0.86

ml = Max. load · me = Max. efficiency · fa = Free air · cs = Customer specification · ce = Customer equipment  
Subject to change



### Technical description

<b>Weight</b>	2.7 kg
<b>Fan size</b>	208 mm
<b>Rotor surface</b>	Painted black
<b>Impeller material</b>	PA66 plastic, glass-fiber reinforced
<b>Fan housing material</b>	Die-cast aluminum, painted black
<b>Number of blades</b>	5
<b>Airflow direction</b>	"V"
<b>Direction of rotation</b>	Counterclockwise, viewed toward rotor
<b>Degree of protection</b>	IP44; installation- and position-dependent
<b>Insulation class</b>	"F"
<b>Moisture (F) / Environmental (H) protection class</b>	H0 - dry environment
<b>Max. permitted ambient temp. for motor (transport/storage)</b>	+ 80 °C
<b>Min. permitted ambient temp. for motor (transport/storage)</b>	- 40 °C
<b>Installation position</b>	Any
<b>Condensation drainage holes</b>	None
<b>Mode</b>	S1
<b>Motor bearing</b>	Ball bearing
<b>Touch current according to IEC 60990 (measuring circuit Fig. 4, TN system)</b>	< 0.75 mA
<b>Electrical hookup</b>	Via terminal strip, capacitor connected
<b>Motor protection</b>	Thermal overload protector (TOP) internally connected
<b>With cable</b>	Lateral
<b>Protection class</b>	I (with customer connection of protective earth)
<b>Motor capacitor according to EN 60252-1 in safety protection class</b>	S0
<b>Conformity with standards</b>	EN 60335-1; CE
<b>Approval</b>	CSA C22.2 No. 113; UL 507

Product drawing

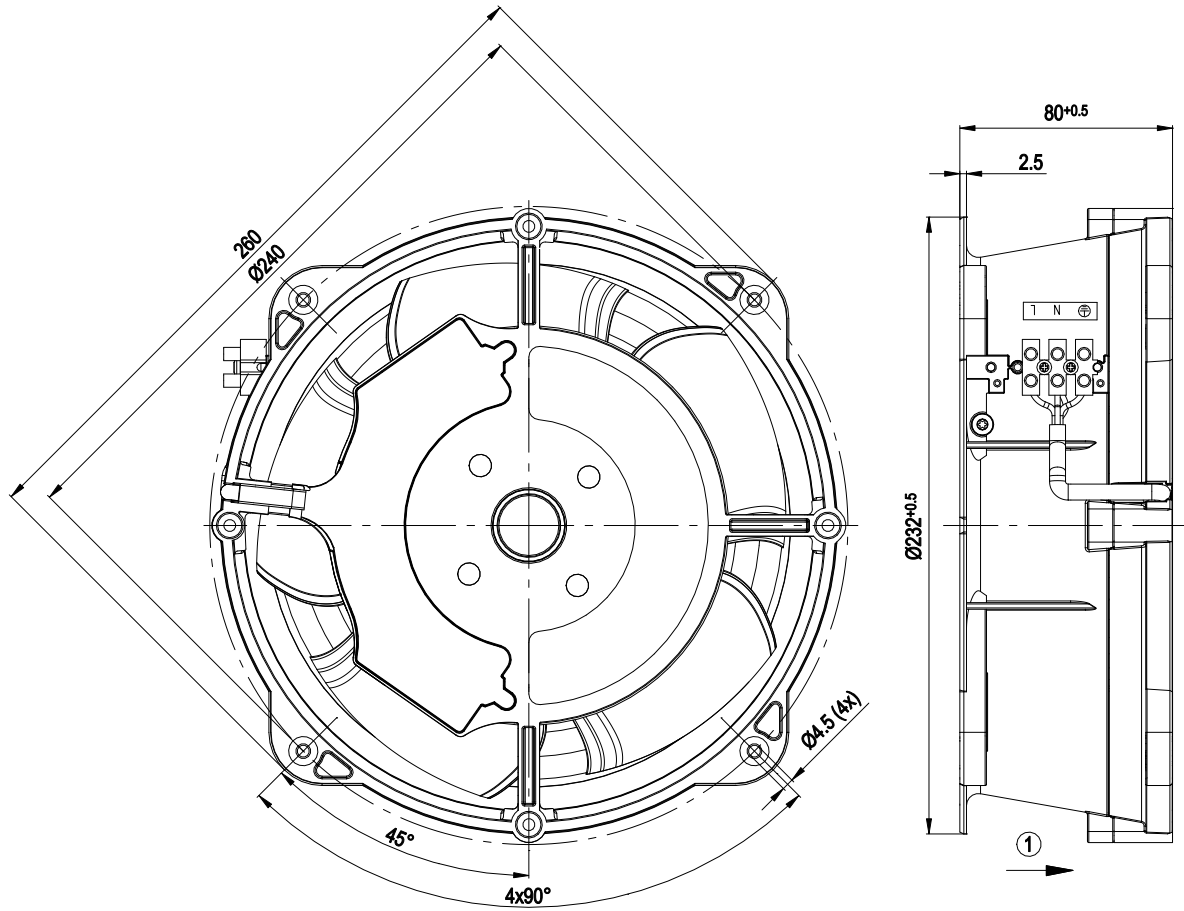

1 Direction of air flow "V"

Connection diagram

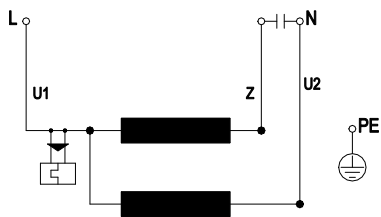

U1	blue	Z	brown	U2	black
PE	green/yellow				



## Curves: Air performance 50 Hz

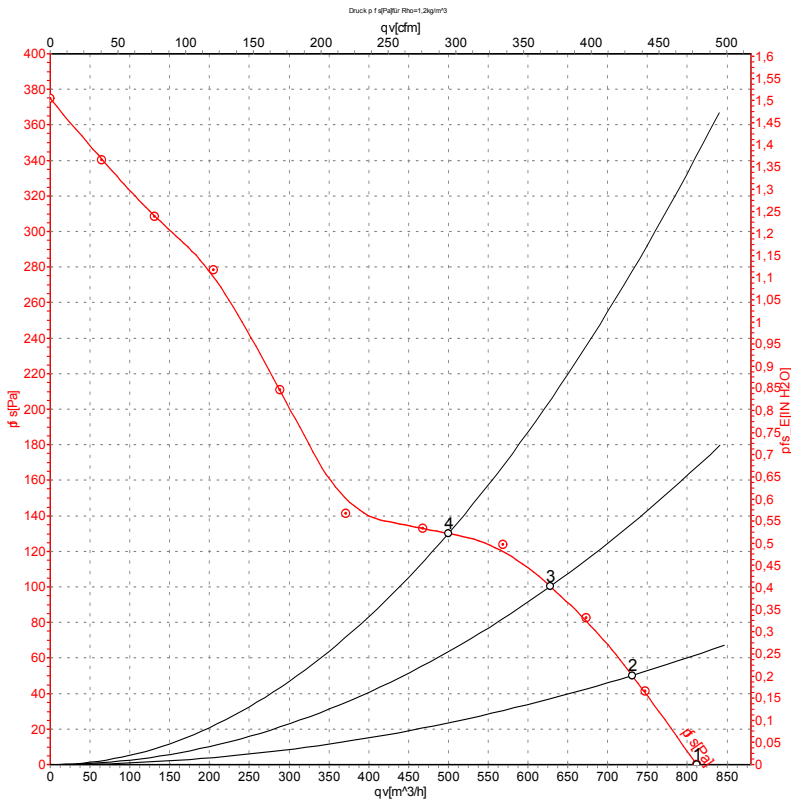

Measurement: LU-58196-1

Air performance measured according to ISO 5801 installation category A. For detailed information on the measurement setup, contact ebm-papst. Intake sound level: Sound power level according to ISO 13347 / sound pressure level measured at 1 m distance from fan axis. The values given are valid under the specified measuring conditions and may vary due to conditions of installation. For deviations from the standard configuration, the parameters have to be checked on the installed unit.

## Measured values

	U	f	n	$P_e$	I	$q_v$	$p_{fs}$	$q_v$	$p_{fs}$
	V	Hz	min <sup>-1</sup>	W	A	m³/h	Pa	cfm	inH2O
1	230	50	2750	67	0.33	810	0	480	0.00
2	230	50	2710	74	0.37	730	50	430	0.20
3	230	50	2685	77	0.38	630	100	370	0.40
4	230	50	2690	76	0.37	500	130	295	0.52

U = Power supply · f = Frequency · n = Speed (rpm) ·  $P_e$  = Power consumption · I = Current draw ·  $q_v$  = Air flow ·  $p_{fs}$  = Pressure increase



## Curves: Air performance 60 Hz

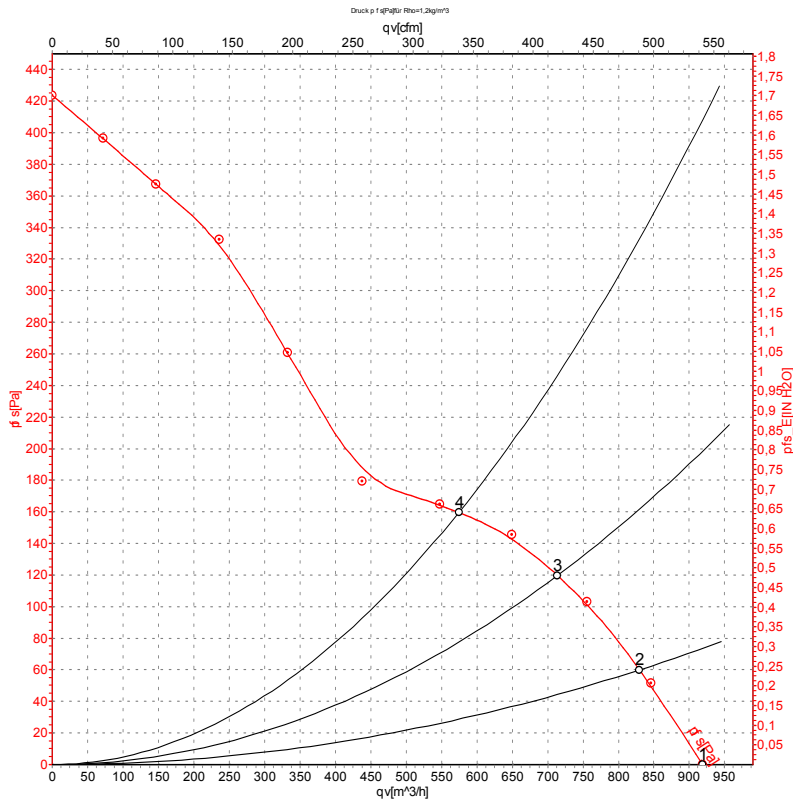

Measurement: LU-58197-1

Air performance measured according to ISO 5801 installation category A. For detailed information on the measurement setup, contact ebm-papst. Intake sound level: Sound power level according to ISO 13347 / sound pressure level measured at 1 m distance from fan axis. The values given are valid under the specified measuring conditions and may vary due to conditions of installation. For deviations from the standard configuration, the parameters have to be checked on the installed unit.

## Measured values

	U	f	n	P <sub>e</sub>	I	q <sub>v</sub>	P <sub>fs</sub>	q <sub>v</sub>	P <sub>fs</sub>
	V	Hz	min <sup>-1</sup>	W	A	m <sup>3</sup> /h	Pa	cfm	inH <sub>2</sub> O
1	230	60	3100	87	0.39	920	0	540	0.00
2	230	60	3045	95	0.42	830	60	490	0.24
3	230	60	2980	102	0.44	715	120	420	0.48
4	230	60	2980	101	0.44	575	160	340	0.64

U = Power supply · f = Frequency · n = Speed (rpm) · P<sub>e</sub> = Power consumption · I = Current draw · q<sub>v</sub> = Air flow · P<sub>fs</sub> = Pressure increase

