

W2S130-AB03-21

AC axial compact fan



ASIA PACIFIC SHENGRUI LIMITED

Phone +00852 56261528

info@apacshengrui.com

www.apacfan.com

Nominal data

Type	W2S130-AB03-21		
Motor	M2S052-CA		
Phase		1~	1~
Nominal voltage	VAC	230	230
Frequency	Hz	50	60
Type of data definition		fa	fa
Valid for approval / standard		CE	CE
Speed	min ⁻¹	2800	3250
Power input	W	45	39
Current draw	A	0.31	0.25
Max. back pressure	Pa	80	120
Min. ambient temperature	°C	-25	-25
Max. ambient temperature	°C	50	80
Starting current	A	0.45	0.40

ml = Max. load · me = Max. efficiency · fa = Running at free air · cs = Customer specs · cu = Customer unit
Subject to alterations



Technical features

Mass	1.08 kg
Size	130 mm
Surface of rotor	Coated in black
Material of blades	Sheet steel, coated in black
Material of wall ring	Die-cast aluminium, coated in black
Number of blades	7
Direction of air flow	"V"
Direction of rotation	Counter-clockwise, seen on rotor
Type of protection	IP 20
Insulation class	"F"
Max. permissible ambient motor temp. (transp./ storage)	+ 80 °C
Min. permissible ambient motor temp. (transp./storage)	- 40 °C
Mounting position	Any
Condensate discharge holes	None
Operation mode	S1
Motor bearing	Ball bearing
Touch current acc. IEC 60990 (measuring network Fig. 4, TN system)	< 0.75 mA
Motor protection	Thermal overload protector (TOP) wired internally
Cable exit	Variable
Protection class	I (if protective earth is connected by customer)
Product conforming to standard	EN 60335-1; CE
Approval	UL 1004-1; CSA C22.2 Nr.100

Product drawing

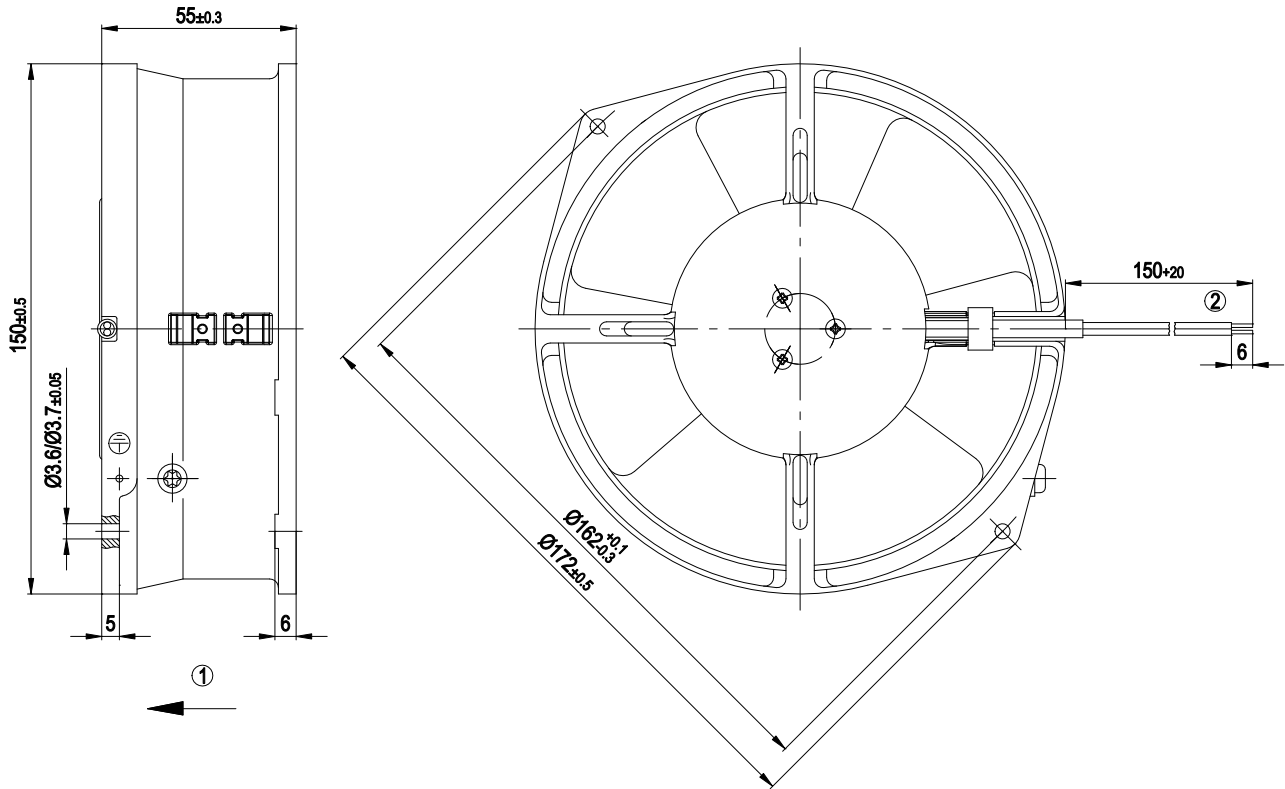

- 1 Direction of air flow "V"
- 2 Connection line AWG20, 2x brass lead tips crimped

Connection screen

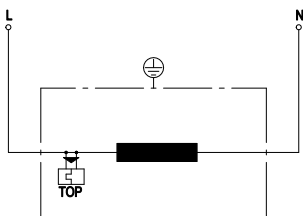

- L = black
- N = black
- TOP = Thermal overload protector

Charts: Air flow 50 Hz

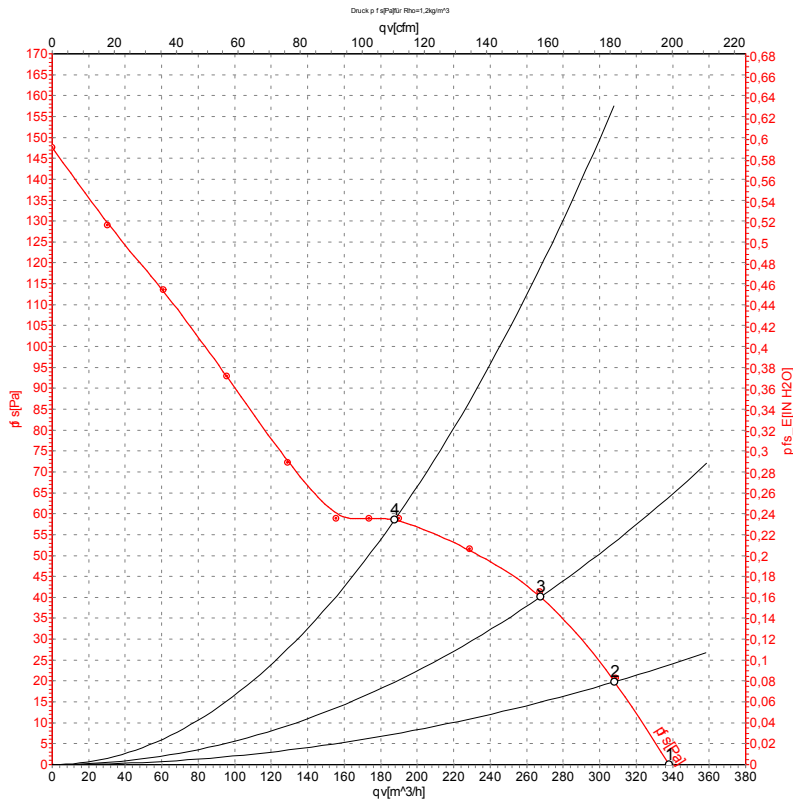

Measurement: LU-58475

Air performance measured as per ISO 5801 Installation category A. For detailed information on the measuring set-up, please contact ebmpapst. Suction-side noise levels: LwA measured as per ISO 13347 / LpA measured with 1m distance to fan axis. The values given are valid under the measuring conditions mentioned above and may vary according to the actual installation situation. With any deviation from the standard set-up, the specific values have to be checked and reviewed with the unit installed.

Measured values

	U	f	n	P _e	I	qv	P _{fs}
	V	Hz	min ⁻¹	W	A	m ³ /h	Pa
1	230	50	2800	45	0.31	340	0
2	230	50	2795	45	0.31	310	20
3	230	50	2780	46	0.31	270	40
4	230	50	2780	46	0.31	190	59

U = Supply voltage · f = Frequency · n = Speed · P_e = Power input · I = Current draw · qv = Air flow · P_{fs} = Pressure increase



Charts: Air flow 60 Hz

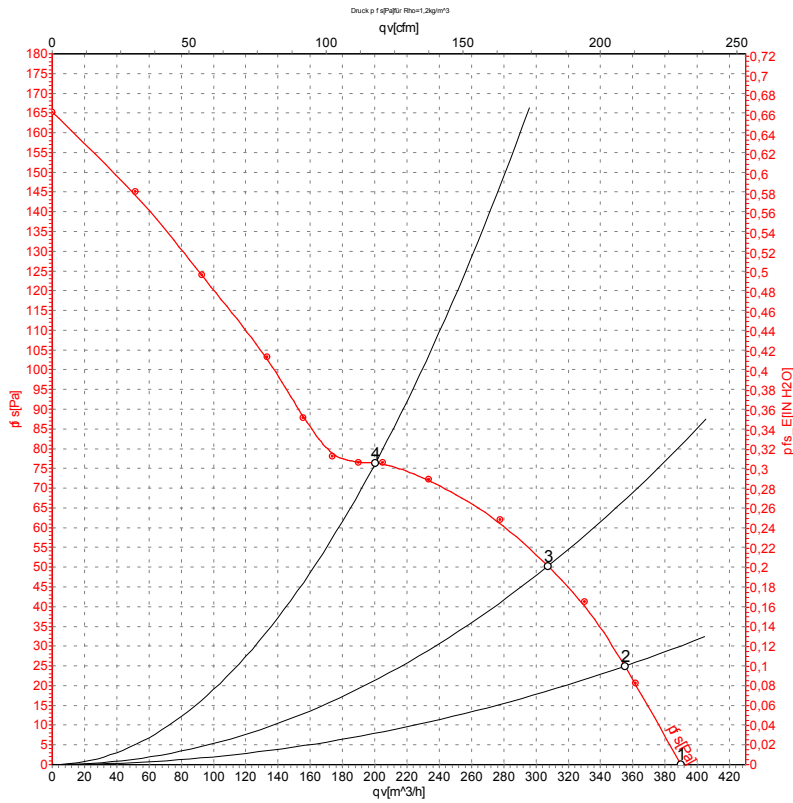

Measurement: LU-58476

Air performance measured as per ISO 5801 Installation category A. For detailed information on the measuring set-up, please contact ebmpapst. Suction-side noise levels: L_{wA} measured as per ISO 13347 / L_{pA} measured with 1m distance to fan axis. The values given are valid under the measuring conditions mentioned above and may vary according to the actual installation situation. With any deviation from the standard set-up, the specific values have to be checked and reviewed with the unit installed.

Measured values

	U	f	n	P _e	I	qv	P _{fs}
	V	Hz	min ⁻¹	W	A	m ³ /h	Pa
1	230	60	3250	39	0.25	390	0
2	230	60	3200	42	0.25	355	25
3	230	60	3165	43	0.26	305	50
4	230	60	3170	43	0.26	200	75

U = Supply voltage · f = Frequency · n = Speed · P_e = Power input · I = Current draw · qv = Air flow · P_{fs} = Pressure increase

