

K3G250-AV29-B2

# EC centrifugal module - RadiPac

backward curved, single inlet

with support bracket



**ASIA PACIFIC SHENGRUI LIMITED**

Phone+00852 56261528

info@apacshengrui.com

www.apacfan.com



## Nominal data

Type	K3G250-AV29-B2	
Motor	M3G084-FA	
Phase		1~
Nominal voltage	VAC	230
Nominal voltage range	VAC	200 .. 277
Frequency	Hz	50/60
Type of data definition		ml
Speed	min <sup>-1</sup>	3450
Power input	W	750
Current draw	A	3.3
Min. ambient temperature	°C	-25
Max. ambient temperature	°C	40

ml = Max. load · me = Max. efficiency · fa = Running at free air · cs = Customer specs · cu = Customer unit  
Subject to alterations

## Data according to ErP directive

Installation category	A
Efficiency category	Static
Variable speed drive	Yes
Specific ratio*	1.01

\* Specific ratio =  $1 + p_{fs} / 100\,000\text{ Pa}$

	Actual	Request 2013	Request 2015
Overall efficiency $\eta_{es}$	62.5	46.2	50.2
Efficiency grade N	74.3	58	62
Power input $P_{ed}$	kW	0.75	
Air flow $q_v$	m <sup>3</sup> /h	1755	
Pressure increase $p_{fs}$	Pa	889	
Speed n	min <sup>-1</sup>	3490	

Data definition with optimum efficiency.  
The ErP data is determined using a motor-impeller combination in a standardised measurement configuration.



## Technical features

<b>Mass</b>	10.1 kg
<b>Size</b>	250 mm
<b>Surface of rotor</b>	Coated in black
<b>Material of electronics housing</b>	Die-cast aluminium
<b>Material of impeller</b>	Aluminium sheet
<b>Material of mounting plate</b>	Sheet steel, galvanised
<b>Material of support bracket</b>	Steel, coated in black
<b>Material of inlet nozzle</b>	Sheet steel, galvanised
<b>Number of blades</b>	7
<b>Direction of rotation</b>	Clockwise, seen on rotor
<b>Type of protection</b>	IP 54
<b>Insulation class</b>	"B"
<b>Humidity class</b>	F3-1
<b>Max. permissible ambient motor temp. (transp./ storage)</b>	+80 °C
<b>Min. permissible ambient motor temp. (transp./storage)</b>	-40 °C
<b>Mounting position</b>	Shaft horizontal or rotor on bottom; rotor on top on request
<b>Condensate discharge holes</b>	Rotor-side
<b>Operation mode</b>	S1
<b>Motor bearing</b>	Ball bearing
<b>Technical features</b>	<ul style="list-style-type: none"> <li>- Output 10 VDC, max. 10 mA</li> <li>- Output 20 VDC, max. 50 mA</li> <li>- Output for slave 0-10 V</li> <li>- Input for sensor 0-10 V or 4-20 mA</li> <li>- Alarm relay</li> <li>- Motor current limit</li> <li>- PFC, active</li> <li>- RS485 MODBUS RTU</li> <li>- Soft start</li> <li>- Control input 0-10 VDC / PWM</li> <li>- Control interface with SELV potential safely disconnected from the mains</li> <li>- Over-temperature protected electronics / motor</li> <li>- Line undervoltage / phase failure detection</li> </ul>
<b>EMC interference immunity</b>	Acc. to EN 61000-6-2 (industrial environment)
<b>EMC harmonics</b>	Acc. to EN 61000-3-2/3
<b>EMC interference emission</b>	Acc. to EN 55022 (Class B, household environment)
<b>Touch current acc. IEC 60990 (measuring network Fig. 4, TN system)</b>	<= 3.5 mA
<b>Electrical leads</b>	Via terminal box
<b>Motor protection</b>	Thermal overload protector (TOP) wired internally
<b>Protection class</b>	I (if protective earth is connected by customer at the connection point of the housing)
<b>Product conforming to standard</b>	EN 61800-5-1; CE
<b>Approval</b>	GOST; CCC

# EC centrifugal module - RadiPac

backward curved, single inlet  
with support bracket

## Product drawing

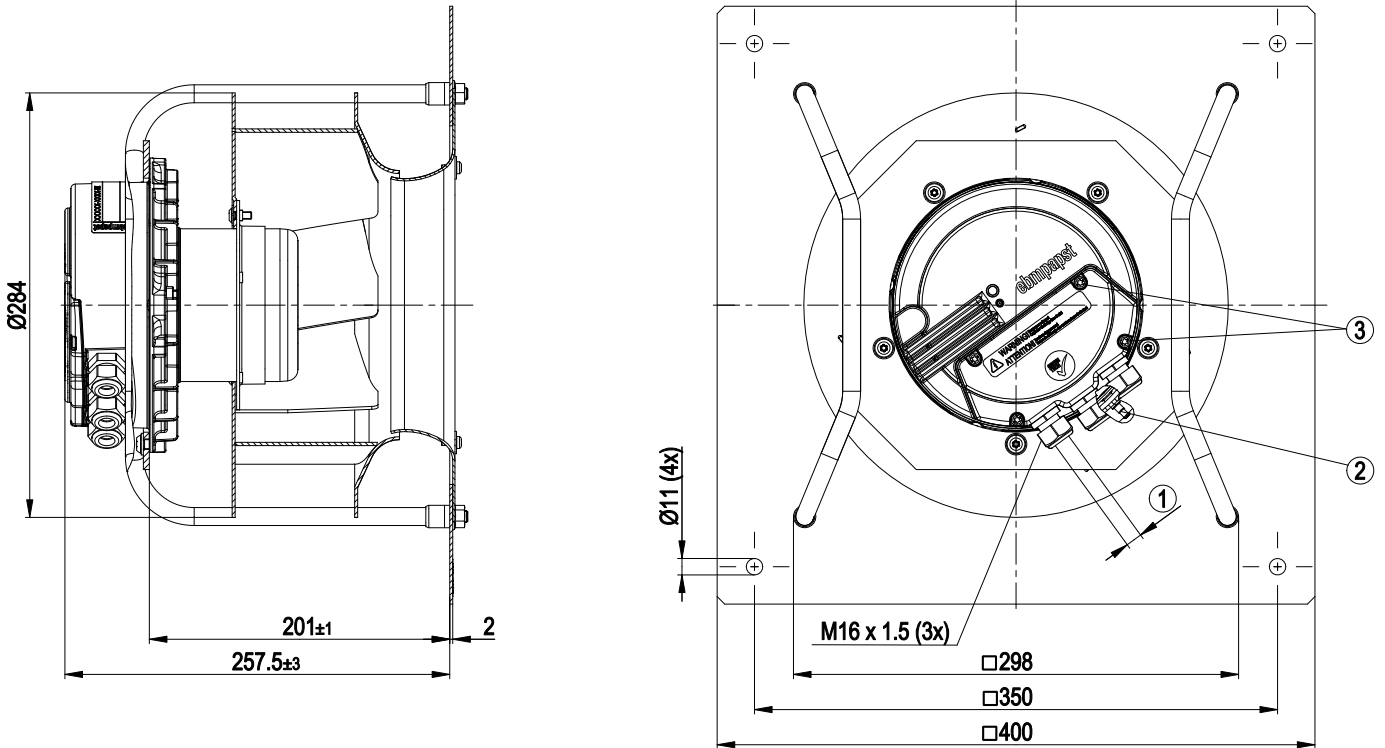

- |   |   |
|---|---|
| 1 | Cable diameter: min. 4 mm, max. 10 mm; tightening torque: 2.5±0.4 Nm    |
| 2 | Inlet nozzle with bleeder connection for pressure relief (k-factor: 70) |
| 3 | Tightening torque 3.5±0.5 Nm  |

# EC centrifugal module - RadiPac

backward curved, single inlet  
with support bracket

## Connection screen

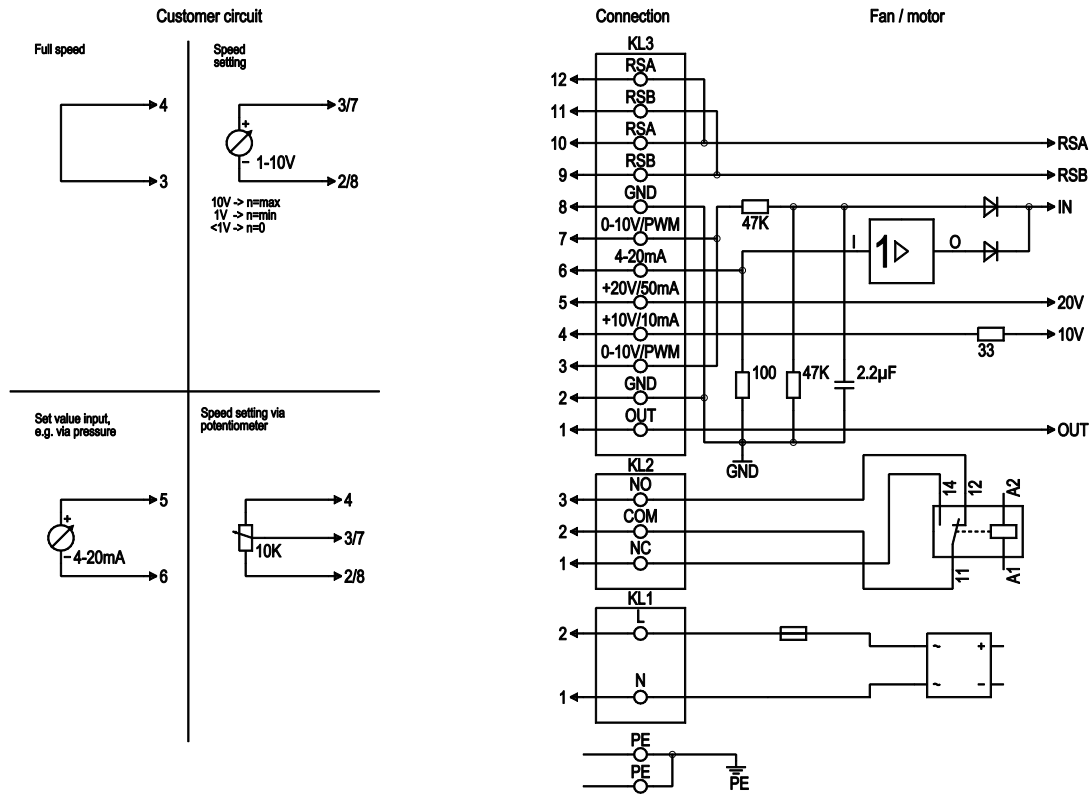

No.	Pin	Signal	Function / assignment
PE	-	PE	Protective earth connection
KL1	1, 2	N, L	Supply voltage, 50/60 Hz
KL2	1	NC	Floating status message contact, break for failure
KL2	2	COM	Floating status message contact, changeover contact, common connection (2 A, max. 250 VAC, min. 10 mA, AC1)
KL2	3	NO	Floating status message contact, normally open, make for failure
KL3	1	OUT	Analogue output, 0-10 VDC, max. 3 mA, SELV, Output of the current motor level control coefficient: 1 V corresponds to 10% level control coefficient, 10 V correspond to 100% level control coefficient.
KL3	2, 8	GND	Reference mass for control interface, SELV
KL3	3, 7	0-10 V	Use control / actual value input 0-10 VDC, impedance 100 kΩ only as alternative to 4-20 mA input, SELV
KL3	4	+10 V	Voltage output 10 VDC (+/- 3%), max. 10 mA, Supply voltage for ext. devices (e.g. potentiometer), SELV
KL3	5	+20 V	Voltage output 20 VDC (+25%/-10%), max. 50 mA Supply voltage for ext. devices (e.g. sensors), SELV
KL3	6	4-20 mA	Use control / actual value input 4-20 mA, impedance 100 Ω, only as alternative to 0-10 V input, SELV
KL3	9, 11	RSB	RS485 interface for MODBUS, RSB
KL3	10, 12	RSA	RS485 interface for MODBUS, RSA



## Charts: Air flow 50 Hz

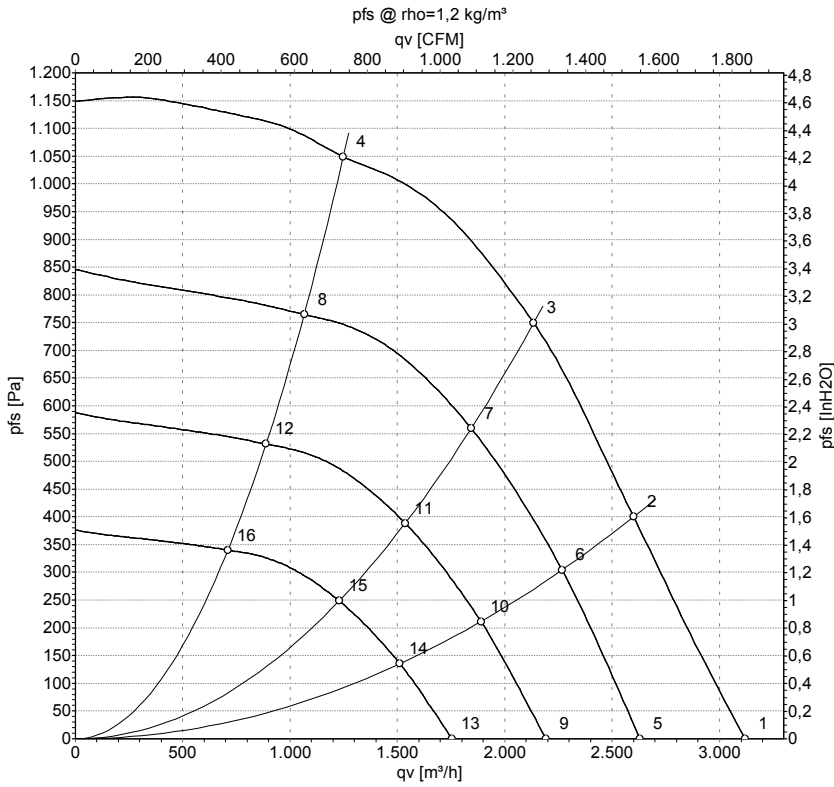

Measurement: LU-142908

Air performance measured as per ISO 5801 Installation category A. For detailed information on the measuring set-up, please contact ebm-papst. Suction-side noise levels: LwA measured as per ISO 13347 / LpA measured with 1m distance to fan axis. The values given are valid under the measuring conditions mentioned above and may vary according to the actual installation situation. With any deviation from the standard set-up, the specific values have to be checked and reviewed with the unit installed.

## Measured values

	U	f	n	P <sub>ed</sub>	I	LpA <sub>in</sub>	LwA <sub>in</sub>	LwA <sub>out</sub>	qv	p <sub>fs</sub>
	V	Hz	min <sup>-1</sup>	W	A	dB(A)	dB(A)	dB(A)	m <sup>3</sup> /h	Pa
1	230	50	3450	581	2.58	77	85	91	3120	0
2	230	50	3450	673	2.98	74	82	88	2600	400
3	230	50	3450	750	3.30	71	79	85	2135	750
4	230	50	3450	691	3.07	79	86	87	1250	1050
5	230	50	3000	349	1.55	73	80	87	2630	0
6	230	50	3000	446	1.97	71	78	84	2265	304
7	230	50	3000	486	2.16	68	75	81	1845	559
8	230	50	3000	432	1.92	75	82	83	1065	765
9	230	50	2500	202	0.90	68	76	82	2195	0
10	230	50	2500	258	1.14	66	74	80	1890	211
11	230	50	2500	281	1.25	63	71	76	1535	388
12	230	50	2500	250	1.11	70	77	78	890	531
13	230	50	2000	103	0.46	63	70	76	1755	0
14	230	50	2000	132	0.59	60	68	74	1510	135
15	230	50	2000	144	0.64	57	65	71	1230	249
16	230	50	2000	128	0.57	64	72	72	710	340

U = Supply voltage · f = Frequency · n = Speed · P<sub>ed</sub> = Power input · I = Current draw · LpA<sub>in</sub> = Sound pressure level inlet side · LwA<sub>in</sub> = Sound power level inlet side · LwA<sub>out</sub> = Sound power level outlet side  
qv = Air flow · p<sub>fs</sub> = Pressure increase

